

## Chapter 7 Diagnosis function

### 7.1 Self diagnosis function of Fnet communication module

#### 7.1.1 Self diagnosis function during running

Error type occurred during normal operation can be known through LED which located on the front of the product. When LED operation is abnormal, see appendix A1.1/A1.2 LED indication if user can fix the error through relevant action, and contact Service station of our company for serious error of hardware.

Items	Contents	Remark
Diagnosis function (Initial self diagnosis)	<p><b>** On-line mode **</b></p> <ol style="list-style-type: none"> <li>1) Memory access error of communication module</li> <li>2) Common RAM access and Reading/Writing error</li> <li>3) Interface error of PLC and IBM_PC</li> <li>4) Frame error during communication</li> <li>5) Error status in physical layer of other station during communication</li> <li>6) Error in physical layer of self station during communication</li> <li>7) Program execution error during communication</li> </ol>	Error code is displayed through LED when error occurred (See Appendix A1.1/A1.2)
Diagnosis function (Communication diagnosis)	<p><b>** Test mode **</b></p> <ol style="list-style-type: none"> <li>1) Diagnosis of network configuration status in physical layer by test. <ul style="list-style-type: none"> <li>- Transmission error of physical layer</li> <li>- Receive error of physical layer</li> </ul> </li> <li>2) Interface error of CPU in communication module and communication chip.</li> </ol>	Error code is displayed through LED when error occurred

#### 7.1.2 Communication diagnosis by test mode

If LED indicates modem or cable problem of Fnet module, connect two module of Fnet with communication cable as Fig. 7.1.2, set the two station numbers identically, set operation mode switch on front part to test mode, and turn the power on, then diagnose the problem according to LED indication.

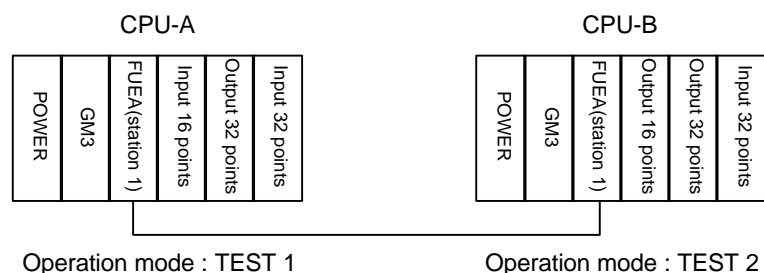

Fig. 7.1.2 Configuration of test system

## 7. Diagnosis function

### How to test

In a system configuration shown above, checks H/W between CPU-A and CPU-B and connection status.

- 1) In a test system configuration shown above, turn the power of CPU-A and CPU-B off and set the mode switch of appropriate module as follows :
  - Mode of communication module, CPU-A = TEST 1 (Transmission mode of communication test)
  - Sets station number switch of CPU-A to station 1 (Communication test for station 1)
  - Mode of communication module, CPU-B = TEST 2 (Receive mode of communication test)
  - Don't change values of other switches.
  - Sets station number switch of CPU-B to station 1 (Communication test for station 1)
- 2) Power on CPU-A and CPU-B.
- 3) LEDs in communication module of CPU-A are operated as follows :

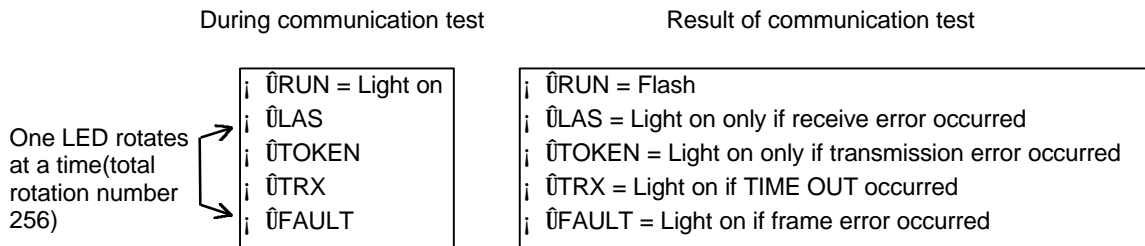

During communication test, rotates up while lighting on FAULT TRX TOKEN LAS FAULT LED 256 times, with RUN LED on. Test result is displayed through LED and the meanings are as shown above. These are displayed during two seconds, and reads station number switch and keep executing with the station.

- 4) LEDs in communication module of CPU-B are operated as follows :

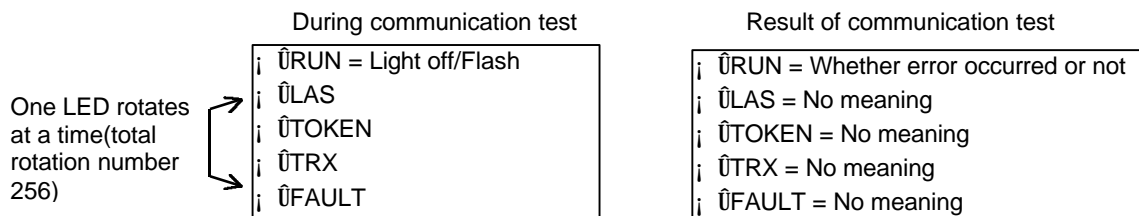

During communication test, rotates up while lighting off FAULT TRX TOKEN LAS FAULT LED 256 times, with RUN LED on. Test result is displayed through RUN LED and communication error occurred during test if RUN LED is turned on.

If error occurs after testing, check the test condition is correct or not. If the same error occurs continuously, contact Service station of our company.

## 7.2 Mnet diagnosis function

### 7.2.1 Diagnosis function types of Mnet communication module

Items	Contents	Remark
Diagnosis function (Self diagnosis + communication diagnosis)	<p style="text-align: center;">** On-line mode **</p> 1) Memory access error of communication module 2) Common RAM access and Reading/Writing error 3) Interface error of PLC and PC 4) Modem error during communication 5) Error status in physical layer of other station during communication 6) Error in physical layer of self station during communication 7) Program execution error during communication	Error code is displayed through LED when error occurred (See appendix A1.7)
	<p style="text-align: center;">** Test mode **</p> 1) Diagnosis of network configuration status in physical layer by test. <ul style="list-style-type: none"> <li>– Interface error of common RAM</li> <li>– Transmission error of physical layer</li> <li>– Receive error of physical layer</li> <li>– Loop back test of physical layer</li> </ul> 2) Interface error of CPU in communication module and TBC	

### 7.2.2 How to diagnose Mnet communication module

Diagnosis of Mnet communication module is made by setting mode switch which is attached on front part of communication module to 2(test 2), and executed with the status that communication cable is not connected. Test1 and test2 are executed internally. Test contents according to each item are as follows :

#### Test 1

- Interface of common RAM
- Transmission test of physical layer
- Receive test of physical layer

#### Test 2

- Interface of common RAM
- Loop back test
- Interface of CPU in communication module and TBC

## 7. Diagnosis function

---

- ┆ ÝTest sequence
  - “ çSets mode switch to 2 with power off
  - “ èPower on
  
- ┆ ÝContents of execution
  - “ çPower on and execution of test 1
    - LED status ┆ ȳ ȳ ȳ ȳ Ū(RUN LED on)
  
  - “ èThe result of test 1 is normal and execution of test 2
    - LED status ┆ ȳ ȳ ȳ ȳ Ū(RUN, IN-RING LED on)
  
  - “ éIf the result of test 1 is abnormal
    - LED status ┆ ȳ ȳ ȳ ȳ Ū(RUN, FAULT LED on)
  
  - “ êIf the result of test 2 is normal
    - LED status ┆ ȳ ȳ ȳ ȳ Ū(FAULT, IN-RING LED on)
  
  - “ ëIf the result of test 2 is normal
    - LED status ┆ ȳ ȳ ȳ ȳ Ū(FAULT LED on)

If test is finished at abnormal LED status as “ éand “ ëcontact Service station of our company.

## Chapter 8 Installation and testing operation

### 8.1 Installation and testing operation of Fnet communication module

GLOFA communication module should be appropriately mounted according to PLC CPU type, and products of communication module which can be mounted according to CPU type are as follows :

Table 8.1 Mounting of communication module according to CPU type

CPU type	Mountable device type	Max. mounting number	Mounting location (slot)	Remark
GM1	G3L-MUEA, G3L-FUEA, G3L-FUOA	4	Main base I/O	
GM2	G3L-MUEA, G3L-FUEA, G3L-FUOA	4	Main base I/O	
GM3	G3L-MUEA, G3L-FUEA, G3L-FUOA	4	Main base I/O	
	G3L-RBEA, G3L-RBOA	1	CPU	Remote I/O
GM4	G4L-FUEA	2	Main base I/O	
	G4L-RBEA	1	CPU	Remote I/O
GM5	G5L-FUEA	1	I/O	
GM6	G6L-FUEA	2	I/O	
FAM4.0	G0L-FUEA	1	16 bit extended slot	Mounted in PC
FAM4.0	G0L-MUEA	1	16 bit extended slot	Mounted in PC
-	G0L-SMQA	1	Stand-alone type	Remote output
-	G0L-SMIA	1	Stand-alone type	Remote input
-	G0L-SMHA	1	Stand-alone type	Remote combined

#### 8.1.1 Installation of Fnet master module

- 1) In the types of master module, there are electric communication module of G3L-FUEA, G4L-FUEA, G5L-FUEA and G6L-FUEA, optical communication module of G3L-FUOA, and G0L-FUEA which is used in IBM-PC. Communication module can be mounted up to 4 in GM1, GM2, and GM3 PLC, and these can be mounted only in main base.
- 2) Communication module can be mounted up to 2 in main base in GM4 and GM6 PLC(Extended base is not available for this module).
- 3) Only one G5L-FUEA module can be mounted in GM5 PLC, and mount it the first location of extended base.
- 4) G0L-FUEA is mounted in one of 16 bit extended slot of compatible IBM PC, and setting of port and memory address shouldn't be duplicated with other device's(See 3.2.3 G0L-FUEA structure).

## 8. Installation and testing operation

### 8.1.2 Installation of Fnet slave module

In types of slave module, there are electric communication module of G3L-RBEA and G4L-RBEA, optical communication module of G3L-RBOA, and standalone remote(G0L-SMQA, G0L-SMIA, G0L-SMHA) I/O station of 16 point output, input, and combined.

Fig. 8.1.2 shows example of mounting and extending of slave in GM base.

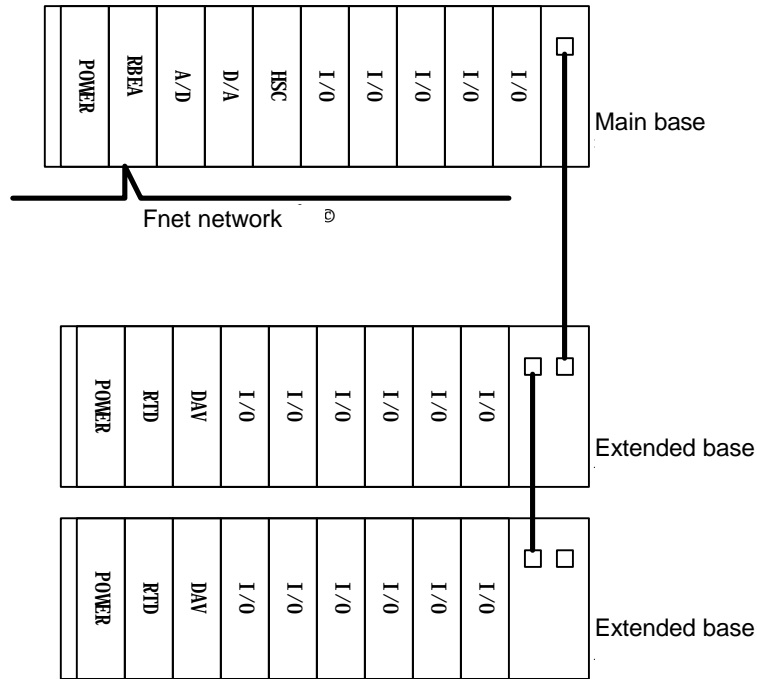

Fig. 8.1.2 How to mount and install

Table 8.1.2 shows list of module, which can be used with FSM.

Table 8.1.2 Mountable device in FSM

Available module name	Not available module name	
Product name	Product name	Type name
All types of I/O module	Coordinator module	GM1-CORA
	Interface module	All types
D/A conversion module	Interrupt input module	G□F-INTA
Temperature conversion module	Fnet module	G□I-FUEA/FUOA
	Mnet module	G3L-MUEA
High speed counter module	PID control module	G□F-PIDA
	Analog timer	G□F-AT□A
A/D conversion module	PC communication module	G□L-CUEA

See mounting method of the manual according to CPU type for mounting method of base module.

### 8.1.3 Installation procedure of Fnet module

- 1) Install standard configuration that is needed in system configuration, and select communication module relevant to the type of device.
- 2) This communication module should be mounted when power is off.
- 3) When mounting this communication module, check whether connector of base that module will be mounted has foreign matters or not, and check whether connector pin of this module is normal.
- 4) All communication modules can't be mounted in extended base, they can be mounted only in CPU position of main base.
- 5) Combined mounting of Mnet module and Fnet master module is possible in device of GM1, GM2, and GM3. But mounting number of combined configuration should be 4 or less.
- 6) When mounting this module, insert projecting part of lower part into groove of base board exactly and press it until upper part is locked with locking device of base board, before connecting communication cable. If locking device is not locked completely, error of interface with CPU may be occurred.
- 7) Sets station number and operation mode using switch on the front part of communication module. There should be no duplicated station number in the same network.
- 8) Connect communication cable after mounting electric module, and install terminal resistance at CON1 or CON2 if this module is terminal (Fnet:110Ω, Mnet:75Ω).
- 9) Electric module cable should be connected tightly using screw of cable connector. If mounted station is not terminal, both side of cable can be connected any of CON1 and CON2.
- 10) Turn the power on after connecting communication cable, check whether this module operates normally through LED operation status. If it is normal, download corresponding program to GMWIN and execute the program.
- 11) After mounting optical communication module, insert projecting part of cable connector into groove of communication module connector while pushing connector of optical connector into communication module connector and turning it clockwise direction.
- 12) Communication module for PC can be mounted in ISA bus, and switch of port address and memory address in this module should be configured according to memory environment of PC before mounting it. If port and memory are set to currently using area in PC memory environment, abnormal operation may be occurred or booting may not be possible(See 3.2.3 GOL-FUEA structure). Switch values of port and memory settings of this module are in appendix.
- 13) To mount communication module for PC, insert a module into slot accurately and tighten the module up with screw of upper part not to be shaken, before connecting communication cable.

## 8. Installation and testing operation

### 8.1.4 Cautions on installation of Fnet module

- 1) All other station including this station should have different station number. If duplicated number is used in connection, communication error occurs and normal communication is not possible.
- 2) If module is operated with normal communication, mode switch should be in Run mode. If mode switch of this module is set to test1 and turn the power on when other stations that are connected in network are already in communication, serious error may be occurred in communication of other stations.
- 3) For communication cable, cable of specified specification should be used. Using not specified cable may cause serious communication error.
- 4) Check whether communication cable has disconnection or short, before installation.
- 5) Tighten communication cable connector to fix the cable connection. If cable connection is not perfect, serious error can be occurred.
- 6) If communication cable is twisted as the following figure or not connected well, problem can be occurred in communication.

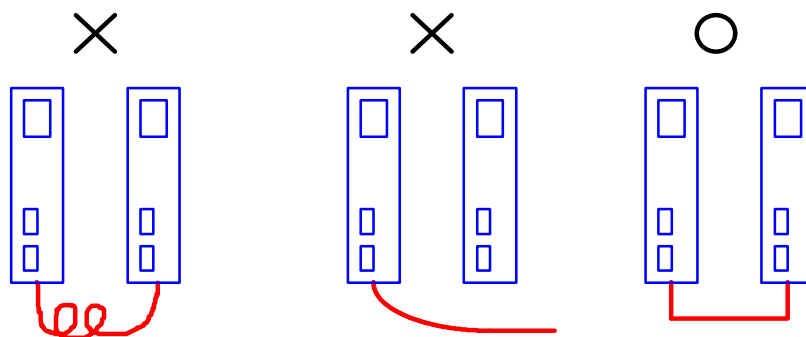

- 7) Branch of cable is not allowed.

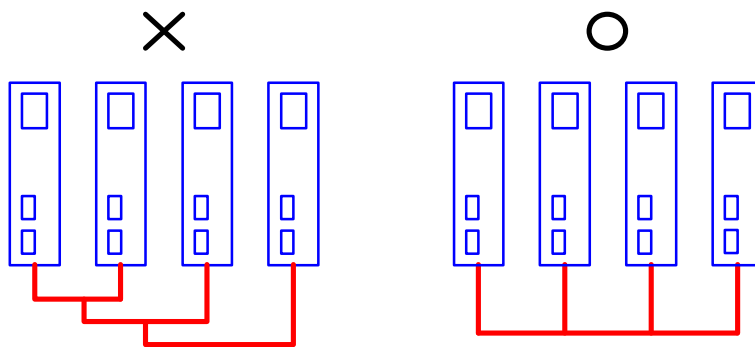

- 8) Connection of network through communication cable should not be a closed circuit.

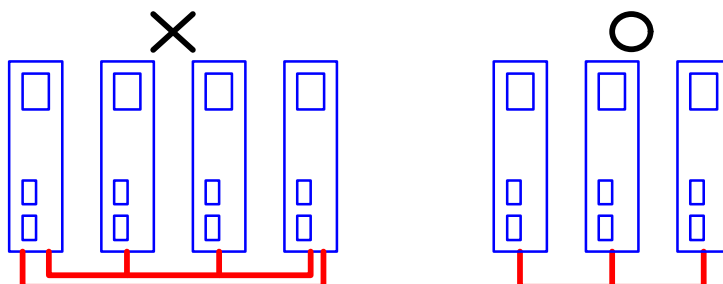

- 9) Choose one from both terminals in network system, connect its terminal connector with FG of PLC or installed device as the following.

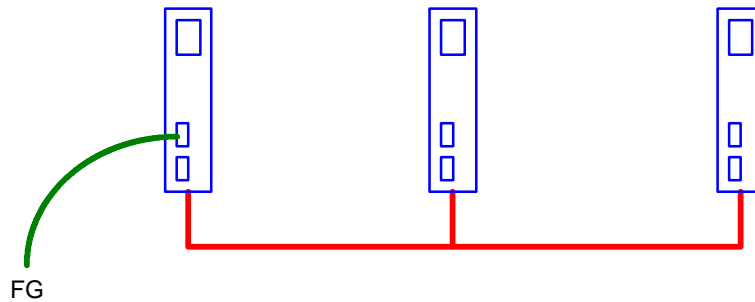

### Remark

If communication status is bad when connection is made as above, this is caused by serious noise from FG. Therefore, user should eliminate its cause or not connect to FG.

- 10) If communication cable is connected with long distance, wiring should be far away from power line or inductive noise.
- 11) Shield line of communication cable (twisted pair) should be connected firmly with connector body inside of the 9 pin metal case for connection (See 4.4.1 Electric (twisted pair) cable wiring).
- 12) Optical communication cable consists of TX and RX lines. Connect them to Tx/Rx connector of optical communication module as the following figure. If polarity of Tx/Rx is changed each other, communication is impossible, so polarity should not be changed (See 4.3.3 Optical cable connection).

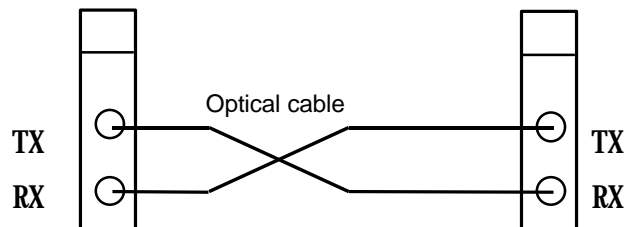

- 13) For not using connector of optical communication module, cover should be used on connector part to prevent foreign matters from coming in.
- 14) If LED operation is abnormal, see 'chap. 9 Troubleshooting' of this manual to check the cause of the error. If the error occurs continuously after management, contact Service station.

## 8. Installation and testing operation

---

### 8.1.5 Preparations during testing operation of Fnet module

This explains contents to be checked before testing operation of Fnet communication module.

#### 1) Communication module to be mounted in PLC

Items to be checked	Contents
Mounting check of Base module	<ul style="list-style-type: none"><li>- Does using voltage of power module comply with specifications of power module?</li><li>- Is battery of CPU module connected?</li><li>- Is mounting of all base modules perfect? ⇒ See product manual according to each PLC type.</li></ul>
Connection status of Communication cable	<ul style="list-style-type: none"><li>- Is connection status of communication cable perfect?</li><li>- Is connection type of each cable open loop?</li></ul>
Module mounting	<ul style="list-style-type: none"><li>- Is mounting status of communication module which is mounted in basic base perfect?</li></ul>
Switch checking	<ul style="list-style-type: none"><li>- Is the status of mode switch On-line (switch value is 0)?</li><li>- Is station No. switch correctly set?</li><li>- Is master station No. switch correctly set? (for slave module)</li><li>- Is output option switch correctly set when communication is cut off? (for slave module)</li></ul>

#### 2) Communication module to be mounted in PC

Items to be checked	Contents
Standard check	<ul style="list-style-type: none"><li>- Is PC appropriate IBM-PC compatible?</li><li>- Has PC sufficient environment to install FAM4.0/GMWIN?</li><li>- Has PC space and empty slot to mount this module?</li><li>- Can memory map of PC reserve empty space to use this module? ⇒ See user's manual of FAM4.0/ GMWIN and Appendix of this manual.</li></ul>
Module mounting and FAM4.0/GMWIN installation	<ul style="list-style-type: none"><li>- Reserve empty space of 32K byte in memory map of PC, select this area for the memory switch of this module, set port address.</li><li>- Mount and fix this module into the slot to be inserted.</li></ul>
Switch recheck	<ul style="list-style-type: none"><li>- Are memory switch and port switch correctly set?</li><li>- Is mode switch set to On-line (switch value is 0) status?</li><li>- Is station number switch correctly set?</li></ul>

### 8.1.6 Testing operation procedure of Fnet module

This shows the sequence from completion of PLC installation to the testing operation.

#### 1) Communication module to be mounted in PLC

Starting
<p><b>Power on :</b></p> <p>(1) Check input power.</p> <p>(2) Check the connection of communication cable.</p> <p>(3) Power on.</p> <p>(4) Check power LED light of power module.</p> <p>(5) Check LED status of CPU module</p> <p style="padding-left: 20px;">⇒ If abnormal, see Troubleshooting of manual according to each PLC type.</p> <p>(6) Check whether LED status of communication module is normal or not.</p> <p style="padding-left: 20px;">⇒ If abnormal, see Chap. 9 Troubleshooting of this manual.</p>
↓
<p><b>Programming :</b></p> <p>Programming is prepared in GMWIN, and it is written into CPU module.</p> <p>(Properly use flags that are related to emergency action for communication cut-off during communication with other station and monitoring of other station)</p>
↓
<p><b>Sequence check :</b></p> <p>Checks operation of communication module according to program.</p>
↓
<p><b>Program correction :</b></p> <p>Corrects if there is any error of sequence program.</p>
↓
<p><b>Program preservation :</b></p> <p>(1) Stores program into floppy disk or hard disk.</p> <p>(2) Prints circuit drawing and list with printer.</p> <p>(3) Writes program to memory module, if necessary.</p>
End

## 8. Installation and testing operation

---

### 2) Communication module to be mounted in PC

Starting
----------

Power :

- (1) Check input power.
- (2) Check the connection of communication cable(when cable is connected).
- (3) Power on.
- (4) Check booting status of PC.  
⇒ If abnormal, see Chap. 9 Troubleshooting of user's manual in FAM4.0/GMWIN.
- (5) Check whether LED status of communication module is normal or not.  
⇒ If abnormal, see Chap. 9 Troubleshooting of this manual.
- (6) Check whether this module is initialized or not by executing FAM4.0/GMWIN.  
⇒ See user's manual of FAM 4.0/GMWIN.
- (7) Check LED status of this module.  
⇒ See 'Appendix LED status' of this manual.  
If the operation is abnormal, see chap. 9 Troubleshooting.
- (8) Preparation and execution of program to be executed.  
⇒ See user's manual of FAM4.0/GMWIN.  
If the operation is abnormal, see chap. 9 Troubleshooting of this manual.

¡ ¢

End
-----

- (1) Stop all execution of FAM4.0/GMWIN, and finish.
- (2) Check LED of this module.

## 8.2 Installation and testing operation of Fnet option unit

### 8.2.1 Active coupler of Fnet

#### 1) Mounting and installation

Active coupler means the assembly of G0L-FAPA(Power)/ G0L-FABA(Base)/ G0L-FACA(Module), and this is used to dispart and connect optical signal to many places.

Fig. 8.2.1 shows example of active coupler communication module

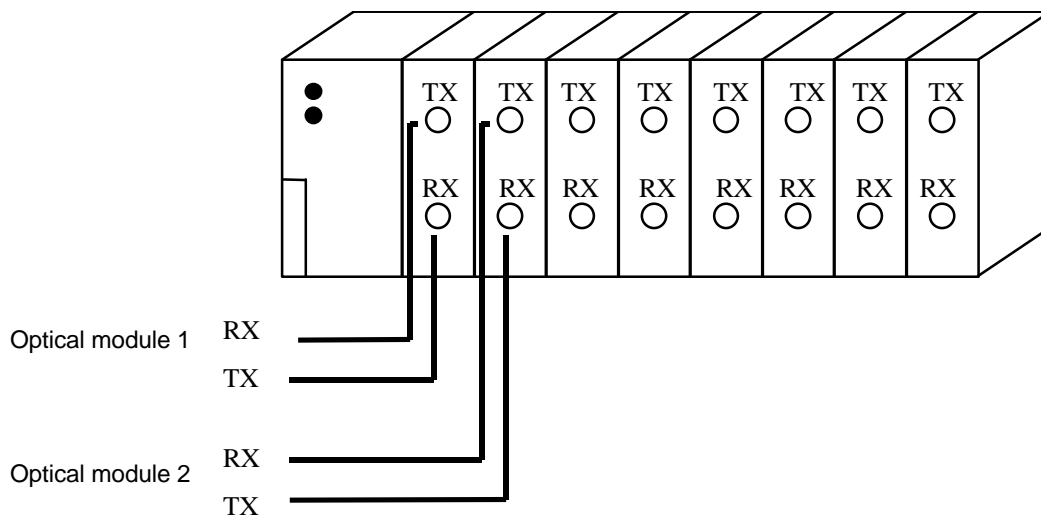

Fig. 8.2.1 Example of active coupler mounting

- (1) Prepare standard configuration that is needed in system configuration, and select communication module that is relevant to the device type.
- (2) This communication module should be mounted when power is off.
- (3) When mounting this communication module, check whether connector of base that module will be mounted has foreign matters or not, and check whether connector pin of this module is broken or not.
- (4) When mounting this module, push active coupler module into groove of upper and lower body in active coupler before connecting communication cable. Push it hard to be completely inserted in base board.
- (5) Connect communication cable after mounting this module.
- (6) Mount dummy module(G0L-FADA) to protect unused slot from foreign matters like dust or others.

## 8. Installation and testing operation

### 8.2.2 E/O converter(Electric/optical signal converter)

This module(GOL-FOEA) converts electric and optical signal of Fnet each other, and this can be configured as follows :

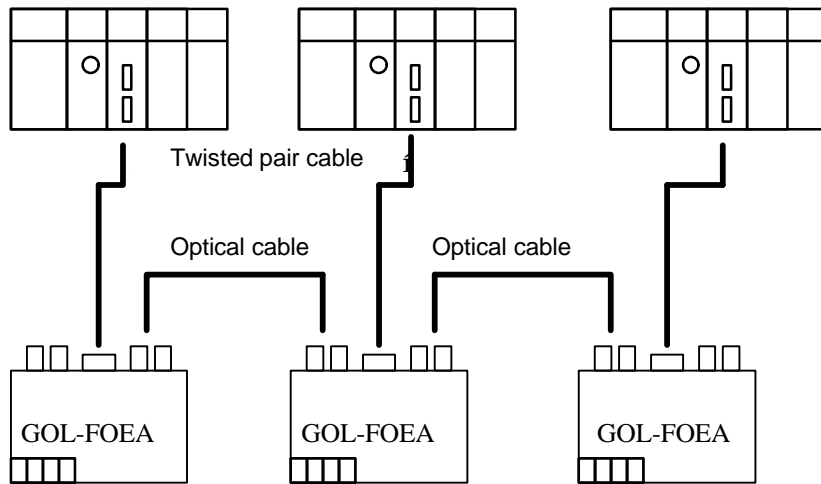

[When optical cable is used to connect between Fnet modules of many stations]

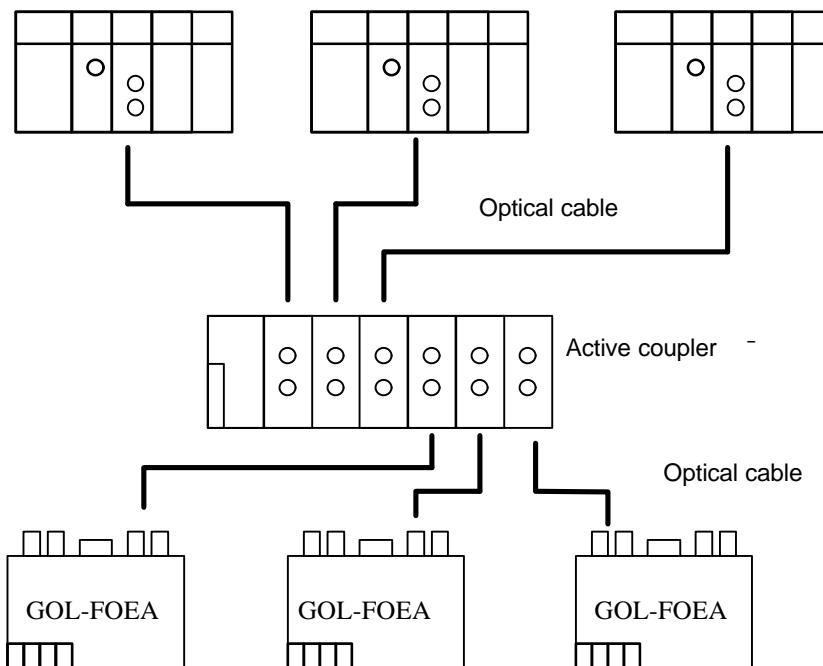

[When optical cable is used to connect between Fnet modules of many stations using active coupler]

- 1) Prepare standard configuration that is needed in system configuration, and select communication module that is relevant to the device type.
- 2) This communication module should be mounted when power is off.
- 3) Connect communication cable after mounting this module.
- 4) Completely connect the connector of optical cable by accurately inserting in Tx/Rx.

### 8.2.3 Repeater(Electric signal restructure)

Repeater(GOL-FREA) is used to restructure the electric signal of Fnet. Installation method is as follows :

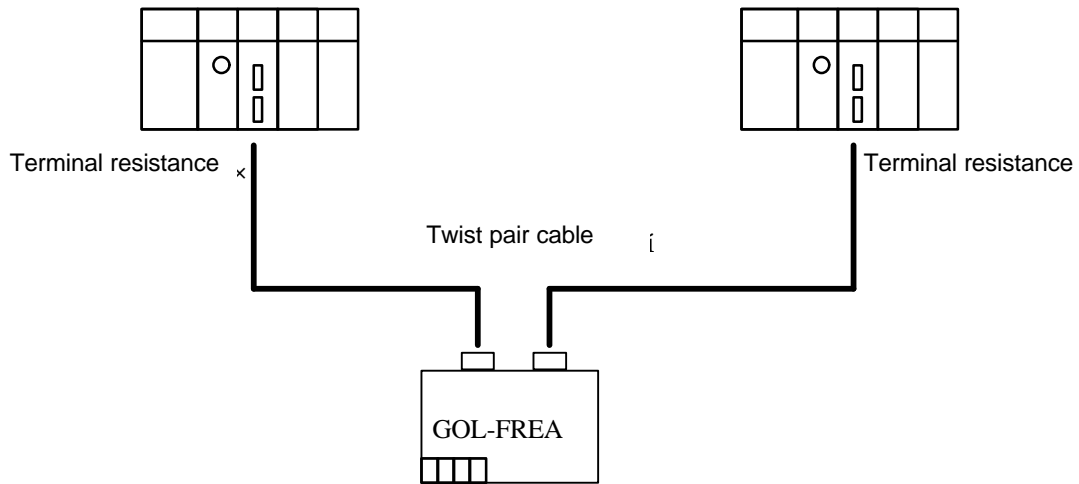

[When the signal between Fnet modules is restruct(to make the signal level 'High')]

- 1) Prepare standard configuration that is needed in system configuration, and select communication module that is relevant to the device type.
- 2) This communication module should be mounted when power is off.
- 3) To connect the cable of electric module, tighten the screw of cable connector to confirm the connection. Terminal resistance is built in the repeater.

**8.3 Installation and testing operation of Mnet communication module**

**8.3.1 Mounting and installation**

In the type of Mnet communication module, there are G3L-MUEA and G0L-MUEA that is used in PC. Communication module can be mounted up to Max.4(including Fnet) in main base of GM1, GM2, and GM3 PLC. Example of mounting is as following figure.

Fig. 8.3.1(A) Example of G3L-MUEA module mounting

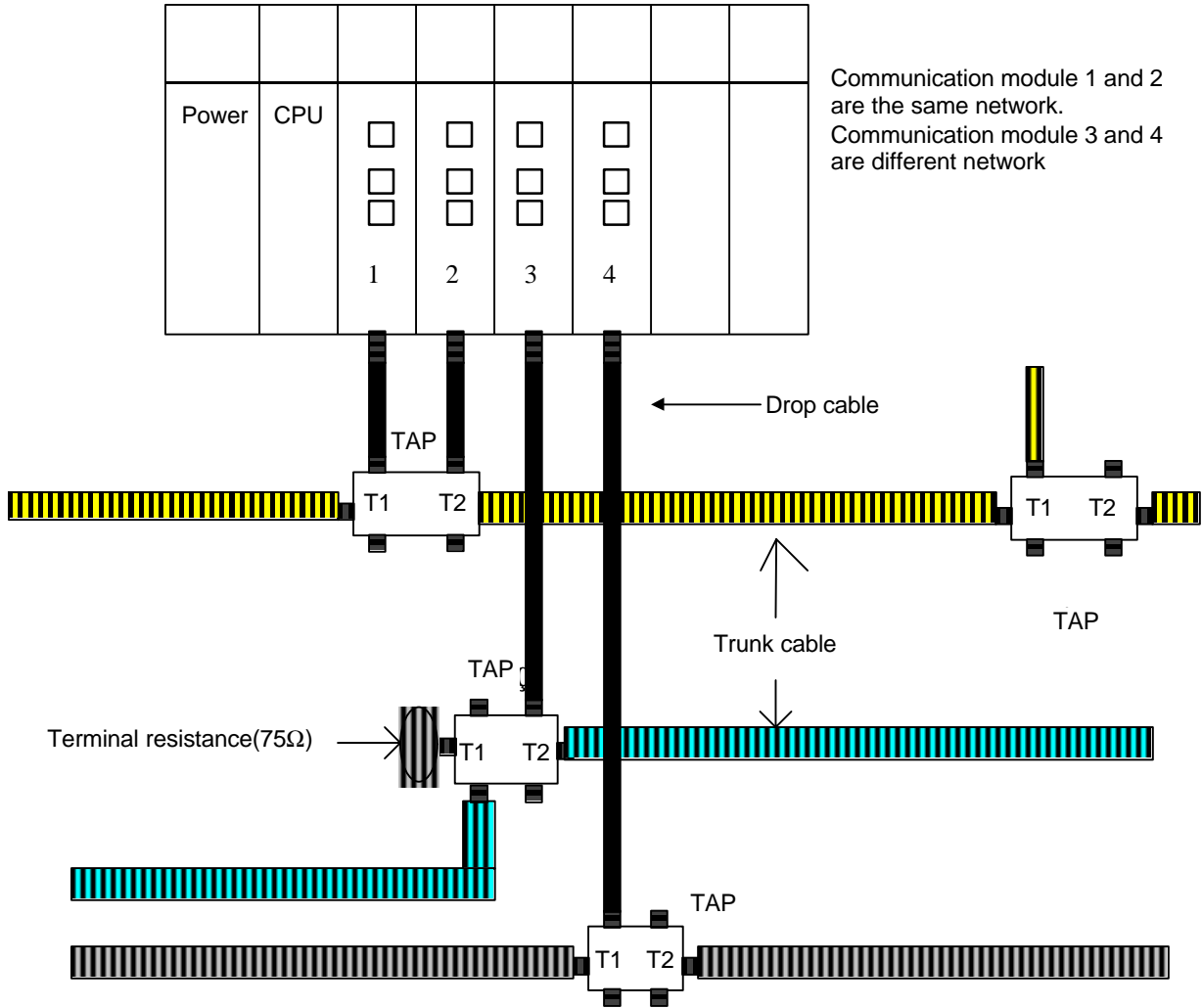

**Remark**

1. Max. distance of trunk cable between TAPs is 700m.
2. Drop cable between TAP and Mnet communication module is max. 50m.
3. Operate while paying attention to TAP direction.

4. Connect the screw for shield connection at the back of TAP with pannel FG.

Fig. 8.3.1(B) Example of mounting of GOL-MUEA module in PC(mounted in 16 bit AT bus)

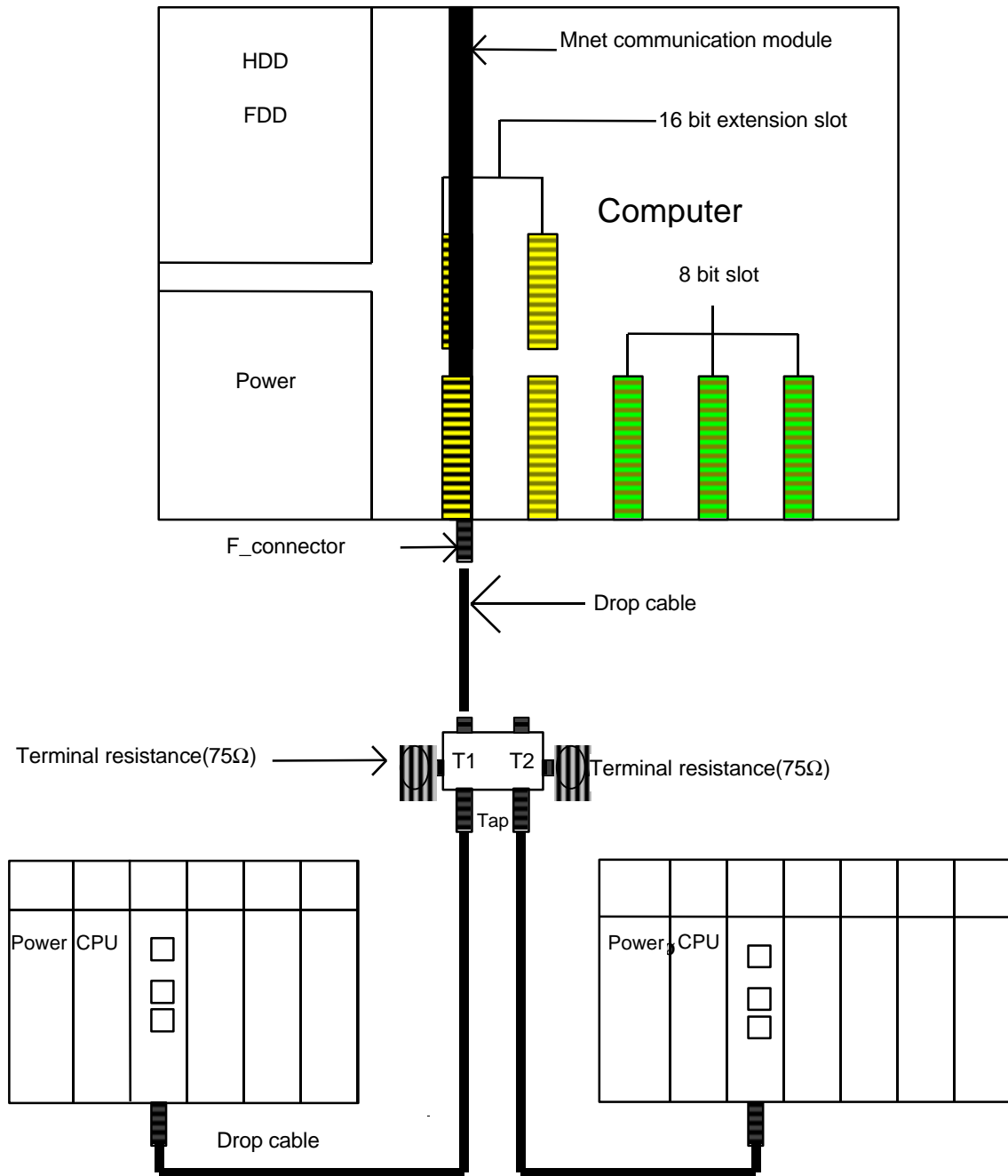

**Remark**

1. Max. distance of trunk cable between TAPs is 700m.
2. Drop cable between TAP and Mnet communication module is max. 50m.
3. Operate while paying attention to TAP direction.

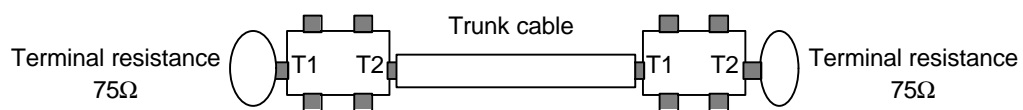

4. Connect the screw for shield connection at the back of TAP with panel FG.

## **8. Installation and testing operation**

---

- 1) Install standard configuration that is needed in system configuration, and select communication module relevant to the type of device.
- 2) This communication module should be mounted when power is off on PLC.
- 3) When mounting this communication module, check whether connector of base that module will be mounted has foreign matters or not, and check whether connector pin of this module is broken or not.
- 4) All communication modules can't be mounted in extended base, they can be mounted only on main base. Communication module should be mounted in a slot that is near with CPU.
- 5) In device of GM1/2/3, combined mounting of Mnet module and Fnet master module is possible. But mounting number of combined configuration should be Max.4 or less.
- 6) When mounting this module, insert projecting part of lower part into groove of base board exactly and press it until upper part is locked with locking device of base board, before connecting communication cable. If locking device is not locked completely, error of interface with CPU may be occurred.
- 7) If network is configured using this communication module, that network should be branched and connected using the TAP for coaxial cable
- 8) In a TAP that is used to branch communication station, terminal of port should be connected with terminal resistance. If terminal resistance is not used, communication error may be occurred.
- 9) Trunk cable should be used between TAPs, and drop cable should be used between connector and TAP of communication module(If drop cable is used instead of trunk cable, communication error may be occurred).
- 10) After connecting communication cable, power on and check whether the operation is normal or not by watching the operation status of LED. If the operation is normal, download appropriate program to PLC of GMWIN, and execute the program.
- 11) Communication module for PC can be mounted in 16 bit slot, and switch of port address and memory address in this module should be configured according to memory environment of PC before mounting it. If port and memory address are set to currently using area in PC memory environment, abnormal operation may be occurred or booting may not be possible. Switch values of port and memory address settings of this module are in appendix.
- 12) To mount communication module for PC, insert a module accurately into slot and tighten the module up with screw of upper part not to be shaken, before connecting communication cable.
- 13) The distance between TAPs is max. 700m, and max. distance of drop cable from TAP to communication module is 50m.
- 14) Using TAP, connect the screw for FG connection in TAP with panel FG line.
- 15) Station number switch that is located on the front of this communication module can be used for high speed communication service only, and MAC address that is written on the case of communication module can be used for station number of other services.

### 8.3.2 Cautions on system configuration

- 1) All other station including this station should have different *high speed link* station number. If duplicated number is used in connection, communication error occurs and normal communication is not possible. Switch value on the front of module should not be duplicated.
- 2) If module is operated with normal communication, mode switch should be in On-line mode. If mode switch of this module is set to test and turn the power on when other stations that are connected in network are already in communicating, serious error may be occurred in communication of other stations.
- 3) For communication cable, cable of specified specification should be used. Using not specified cable may cause serious communication error.
- 4) Check whether communication cable has disconnection or short, before installation.
- 5) Tighten communication cable connector to fix the cable connection. If cable connection is not perfect, serious errors can be occurred.
- 6) If communication cable is connected with long distance, wiring should be far away from power line or inductive noise.
- 7) Coaxial cable is not flexible, so this should be branched away from connector in communication module at least 30cm. If cable is bent at right angle or deformed too much, this may cause disconnection of cable or break of connector in communication module.
- 8) Trunk cable should be used between TAPs, and drop cable should be used between connector and TAP of communication module.
- 9) If LED operation is abnormal, see 'Chap. 9 Troubleshooting' of this manual to check the cause of the error. If the error occurs continuously after management, contact Service station.
- 10) Dual mounting of Mnet communication module(GOL-MUEA) and Fnet communication module(GOL-FUEA) in PC is hard to be used at FAM4.0, dual mounting should be avoided.
- 11) Mounting this module, maintain sufficient gap distance(5cm or more) with other module(base and other additional mounting object) to facilitate connection and mounting of communication connector and cable.

### 8.3.3 Preparations before testing operation

This explains the contents to be checked before commissioning communication module.

#### 1) Communication module to be mounted in PLC

Items to be checked	Contents
Installation and check of standard S/W	– Are installation and operation of GMWIN perfect?
Connection status of communication cable	– Are connection of communication cable and using status of TAP perfect? – Is connection type of each cable open loop?
Module mounting	– Is communication module correctly installed in main base?
Switch check	– Is mode switch On-line(switch value : 0)? – Is station number switch( <i>high speed link</i> ) correctly set?

## 8. Installation and testing operation

### 2) Communication module to be mounted in IBM-PC

Items to be checked	Contents
Standard check	<ul style="list-style-type: none"> <li>- Is PC appropriate IBM-PC compatible?</li> <li>- Has PC sufficient environment to install FAM4.0/GMWIN?</li> <li>- Has PC space and empty slot to mount this module?</li> <li>- Can memory map of PC reserve empty space to use this module? ⇒ See user's manual of FAM4.0/GMWIN and Appendix of this manual.</li> </ul>
Module mounting and FAM4.0/GMWIN installation	<ul style="list-style-type: none"> <li>- Reserve empty space of 64K byte in memory map of PC, select this area for the memory switch of this module, set port address.</li> <li>- Mount and fix this module into the slot to be inserted.</li> </ul>
Switch recheck	<ul style="list-style-type: none"> <li>- Are memory switch and port switch correctly set?</li> <li>- Is mode switch set to On-line (switch value is 0) status?</li> <li>- Is station number switch correctly set?</li> </ul>

### 8.3.4 Procedure of testing operation

This shows the sequence from completion of PLC installation to testing operation.

#### 1) Communication module to be mounted in PLC

Starting
Power on : (1) Check input power. (2) Check the connection of communication cable. (3) Power on. (4) Check power LED light of power module. (5) Check LED status of CPU module. ⇒ If abnormal, see troubleshooting of manual according to each PLC type. (6) Check whether LED status of communication module is normal or not. ⇒ If abnormal, see Chap. 9 Troubleshooting of this manual.
↓
Programming : Programming is prepared in GMWIN, and it is written into CPU module.
↓
Sequence check : Checks operation of communication module according to program.
↓
Program correction : Corrects if there is any error of sequence program.
↓
Program preservation : (1) Stores program into floppy disk or hard disk. (2) Prints circuit drawing and list by printer. (3) Writes program to memory module, if necessary.
End

2) Communication module to be mounted in PC

<b>Starting</b>
<p>Power on :</p> <ol style="list-style-type: none"><li>1) Check input power.</li><li>2) Check the connection of communication cable.</li><li>3) Power on.</li><li>4) Check booting status of PC.<ul style="list-style-type: none"><li>⇒ If booting is not performed, check port address and memory address which are set in communication module and set memory so as not to be duplicated with other devices used in PC.</li><li>⇒ If abnormal, see Chap. 9 Troubleshooting of user's manual in FAM4.0/GMWIN.</li></ul></li><li>5) Check whether LED status of communication module is normal or not.<ul style="list-style-type: none"><li>⇒ If abnormal, see Chap. 9 Troubleshooting of this manual.</li></ul></li><li>6) Check whether this module is initialized or not by executing FAM4.0/GMWIN.<ul style="list-style-type: none"><li>⇒ See user's manual of FAM 4.0/GMWIN.</li></ul></li><li>7) Check LED status of this module.<ul style="list-style-type: none"><li>⇒ See 'Appendix LED status' of this manual.</li><li>If the operation is abnormal, see Chap. 9 Troubleshooting.</li></ul></li><li>8) Preparation and execution of program to be executed.<ul style="list-style-type: none"><li>⇒ See user's manual of FAM4.0/GMWIN.</li><li>If the operation of communication is abnormal, see user's manual of FAM4.0/GMWIN.</li></ul></li></ol>
<b>End</b>
<ol style="list-style-type: none"><li>1) Stop all execution of FAM4.0/GMWIN, and finish.</li><li>2) Check LED of this module.</li></ol>

## 8. Installation and testing operation

### 8.4 Repair and check

Perform routine check and regular check to maintain the best status of this communication module.

#### 8.4.1 Daily check

##### 1) Master of Fnet

Items of routine check are as following table :

Table 8.4.1(A) Items of routine check

Items to be checked		Contents	Criteria of decision	Action to take
Cable connection status		Release of cable	Shall not be any release.	Tighten the cable.
Module connection status		Release of screw	Shall not be any release.	Tighten screw of module.
LED indication	RUN	Flicker check	Flash (Lights-out means interface cut-off with CPU).	See Appendix.
	LAS	Light on Check	LED of only one module among entire module of network should be lighted (Lights of two or more mean abnormal configuration of network).	See Appendix.
	TOKEN	Flicker check	Light off means abnormal (Duplicated station or cable error).	See Appendix.
	TX/RX	Flicker check	Light off means abnormal (Hardware error of module).	See Appendix.
	FAULT	Light off check	Regular flash means system error, and intermittence flash means communication error.	See Appendix.

##### 2) Slave of Fnet

Items of routine check are as following table :

Table 8.4.1(B) Items of routine check

Items to be checked		Contents	Criteria of decision	Action to take
Cable connection status		Release of cable	Shall not be any release.	Tighten the cable.
Connection status of terminal block		Release of terminal screw	Shall not be any release.	Tighten screw of terminal.
		Gap between compression terminals	Shall be relevant gap.	Correct.
LED indication	RUN	Light on check	Check power if light off.	See Appendix.
	TOKEN	Flicker check	Light off means abnormal operation (Duplicated station or cable error).	See Appendix.
	TX/RX	Flicker check	Light off means abnormal operation (Duplicated station or cable error).	See Appendix.
	FAULT	Light off check	Intermittent flash means communication error (Cable connection error, or terminal resistance connection error).	See Appendix.
	SYS FAULT	Light off check	Regular flash means system error (Error code is displayed in LED).	See Appendix.

3) **Communication module of Mnet**

Items of routine check are as following table :

Table 8.4.1(C) Items of routine check

Items to be checked		Contents	Criteria of decision	Action to take
Cable connection status		Release of cable	Shall not be any release.	Tighten the cable.
Connection status of terminal block		Release of terminal screw	Shall not be any release.	Tighten screw of terminal.
		Gap between compression terminals	Shall be relevant gap.	Correct.
LED indication	RUN	Light on check	Light on (Lights-out means abnormal).	See Appendix.
	TX	Light on check in RUN status	Light on (Lights-out means abnormal).	See Appendix.
	RX	Light on check in RUN status	Light on (Lights-out means abnormal).	See Appendix.
	IN-RING	Light on/light off check	Light on (Light off means abnormal) Lights when cable is connected with other station.	See Appendix.
	FAULT	Light off check	Light off (Light on or flash error).	See Appendix.

8.4.2 Regular check

Check following items once or twice per six months, and perform relevant action to take.

Table 8.4.2 Items of regular check

Items to be checked		How to check	Criteria of decision	Action to take
Ambient environment	Ambient temperature	Check using thermometer and hydrometer.	0~55; É	Arrangement by general specification (If it is used in a class, environment of class is used as standard).
	Ambient humidity		5~95%RH	
	Ambient pollution	Check corrosive gas.	Shall not be any corrosive gas.	
Module status	Release, shaking	Shake communication module.	Shall not be any release or shaking.	Tighten the screw.
	Attachment of dust and foreign matter	Visual inspection.	Shall not be any attachment.	Remove
Connection status	Release of terminal screw	Tighten using driver.	Shall not be any release.	Tighten.
	Gap between compression terminals	Visual inspection.	Shall be relevant gap.	Correct.
	Release of connector	Visual inspection.	Shall not be any release.	Fix the connector Tighten the screw.
Power voltage check		Check voltage between terminal.	AC 85~132V AC 170~264V	Change supplied power.