

Chapter. 6 USING THE USER PROGRAM IN FLASH MEMORY

This chapter describes user program storage and operation it.

Flash memory is used to store a user program and installed in PLC.

6.1 Structure

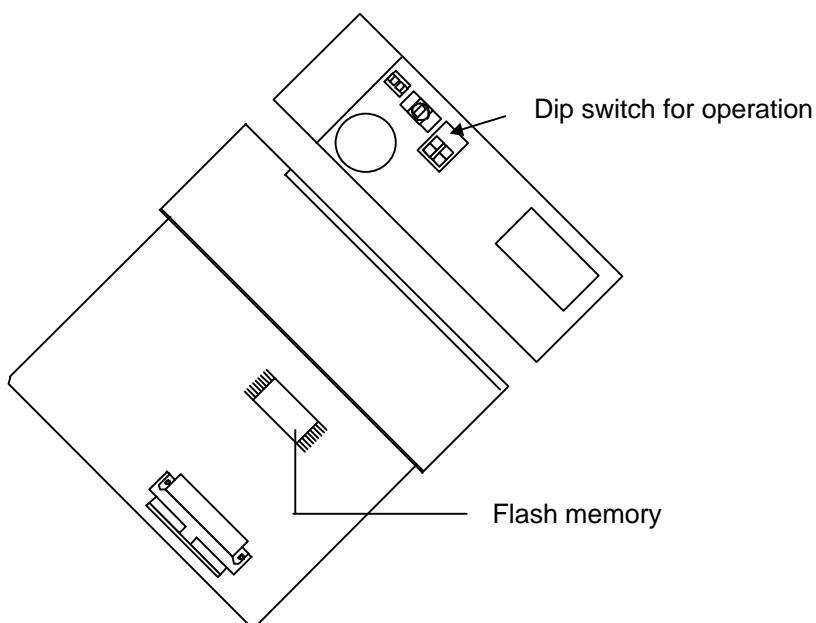

6.2 How to use

Read / Write is available to flash memory in accordance with selection of DIP switch.

Selection of DIP switch for flash memory	Operation
	PLC is operated by the program in flash memory when power on or PLC reset.
	PLC recognize that no program is in flash memory.

(Caution : Lower switch should be at the off position.)

User program can be written to flash memory at the PLC stop mode and then the selection of switch is ignored.