

Chapter 15 The PID function

15.1	Introductions	15-1
15.2	PID control	15-2
	15.2.1 Control actions.....	15-2

15 The PID functions

15.1 Introductions

This chapter will provide information about the built-in PID (Proportional Integral Differential) function of B and C type CPU module. (GM6-CPUB and GM6-CPUC) The GM6 series does not have separated PID module like GM3 and GM4 series, and the PID function is integrated into the CPU module (B and C type)

The PID control means a control action in order to keep the object at a set value (SV). It compares the SV with a sensor measured value (PV : Present Value) and when a difference between them (E : the deviation) is detected, the controller output the manipulate value (MV) to the actuator to eliminate the difference. The PID control consists of three control actions that are proportional (P), integral (I), and differential (D).

The characteristics of the PID function of GM6 is as following;

- the PID function is integrated into the CPU module. Therefore, all PID control action can be performed with F/B (Function Block) without any separated PID module.
- Forward / reverse operations are available
- P operation, PI operation, PID operation and On/Off operation can be selected easily.
- The manual output (the user-defined forced output) is available.
- By proper parameter setting, it can keep stable operation regardless of external disturbance.
- The operation scan time (the interval that PID controller gets a sampling data from actuator) is changeable for optimizing to the system characteristics.

15.2 PID control**15.2.1 Control actions****15.2.1.1 Proportional operation (P operation)**

- 1) P action means a control action that obtain a manipulate value which is proportional to the deviation (E : the difference between SV and PV)
- 2) The deviation (E) is obtained by multiplying a reference value to the actual difference between SV and PV. It prevents the deviation from a sudden change or alteration caused by external disturbance. The formula of deviation is as following;

$$MV = K_p \times [b \times SV - PV]$$

Kp : the proportional constant (gain)
b : reference value
SV : set value
PV : present value

- 3) If the Kp is too large, the PV reaches to the SV swiftly, but it may causes a bad effect like oscillations shown in the Fig. 2.1.
- 4) If the Kp is too small, oscillation will not occur. However, the PV reaches to the SV slowly and an offset may appear between PV and SV shown in the Fig. 2.2.
- 5) The manipulation value (MV) varies from 0 to 4,000. User can define the maximum value of MV (MV_MAX) and minimum value (MV_MIN) within the range 0 ~ 4,000.
- 6) When an offset remains after the system is stabilized, the PV can be reached to the SV by adding a certain value. This value is called as bias value, and user can define the bias value with GM-WIN software.

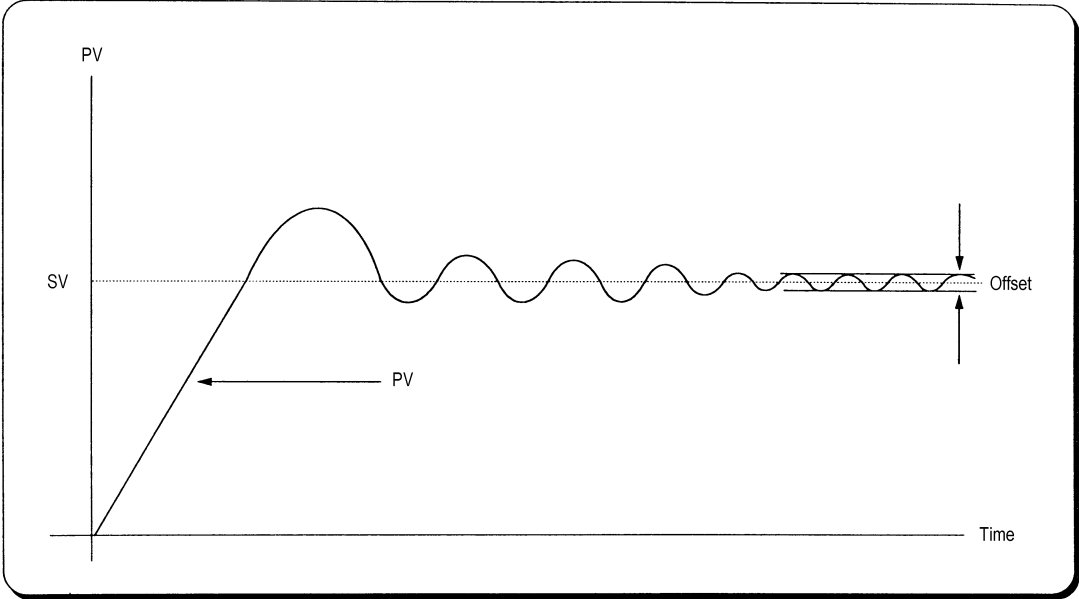
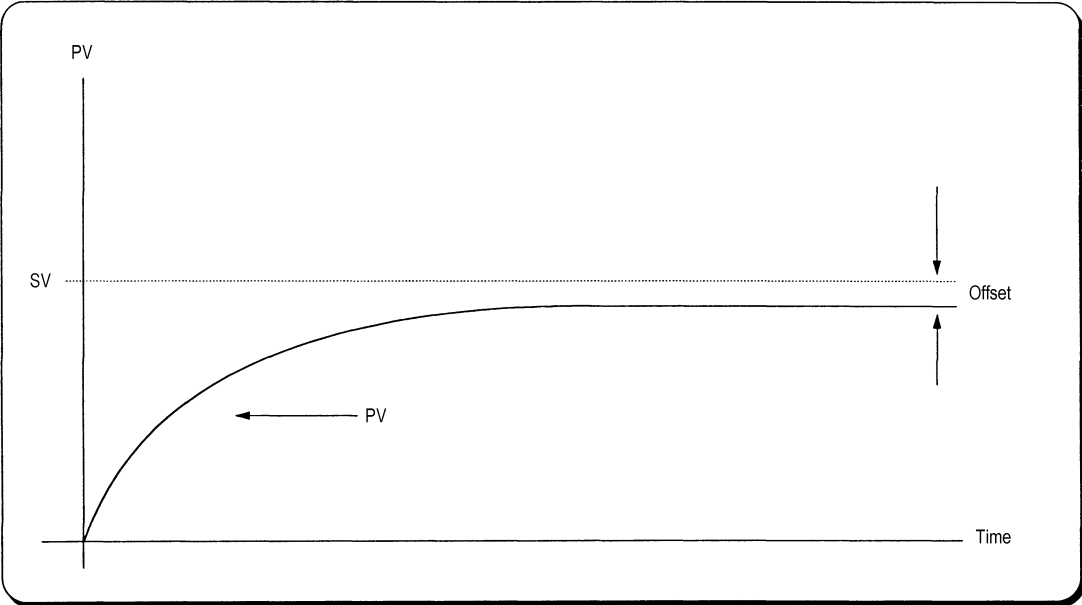

Fig. 2.1 When the proportional constant (K_p) is large

Fig. 2.1 When the proportional constant (K_p) is small



15.2.1.2 Integral operation (I action)

- 1) With integral operation, the manipulate value (MV) is increased or decreased continuously in accordance time in order to eliminate the deviation between the SV and PV. When the deviation is very small, the proportional operation can not produce a proper manipulate value and an offset remains between PV and SV. The integral operation can eliminate the offset value even the deviation is very small.
- 2) The period of the time from when the deviation has occurred in I action to when the MV of I action become that of P action is called Integration time and represented as K_i .
- 3) Integral action when a constant deviation has occurred is shown as the following Fig. 2.4.

Fig. 2.4 The integral action with constant deviation

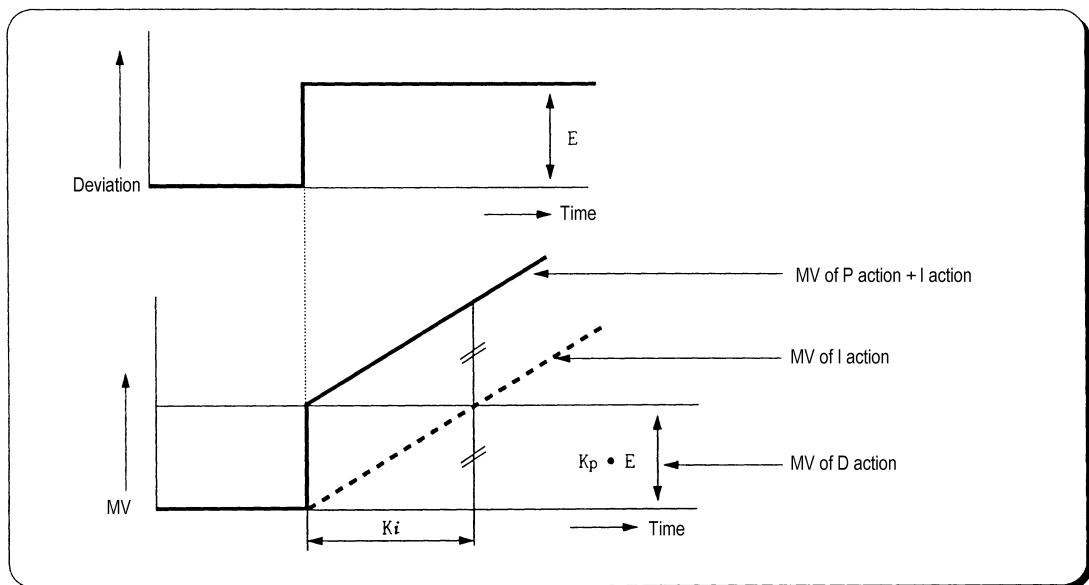

- 4) The expression of I action is as following;

$$MV = \frac{K_p}{K_i} \int E dt$$

As shown in the expression, Integral action can be made stronger or weaker by adjusting integration time (K_i) in I action.

That is, the more the integration time (the longer the integration time) as shown in Fig. 2.5, the lesser the quantity added to or subtracted from the MV and the longer the time needed for the PV to reach the SV.

As shown in Fig. 2.6, when the integration time given is short the PV will approach the SV in short time since the quantity added or subtracted become increased. But, If the integration time is too short then oscillations occur, therefore, the proper P and I value is requested.

- 5) Integral action is used in either PI action in which P action combines with I action or

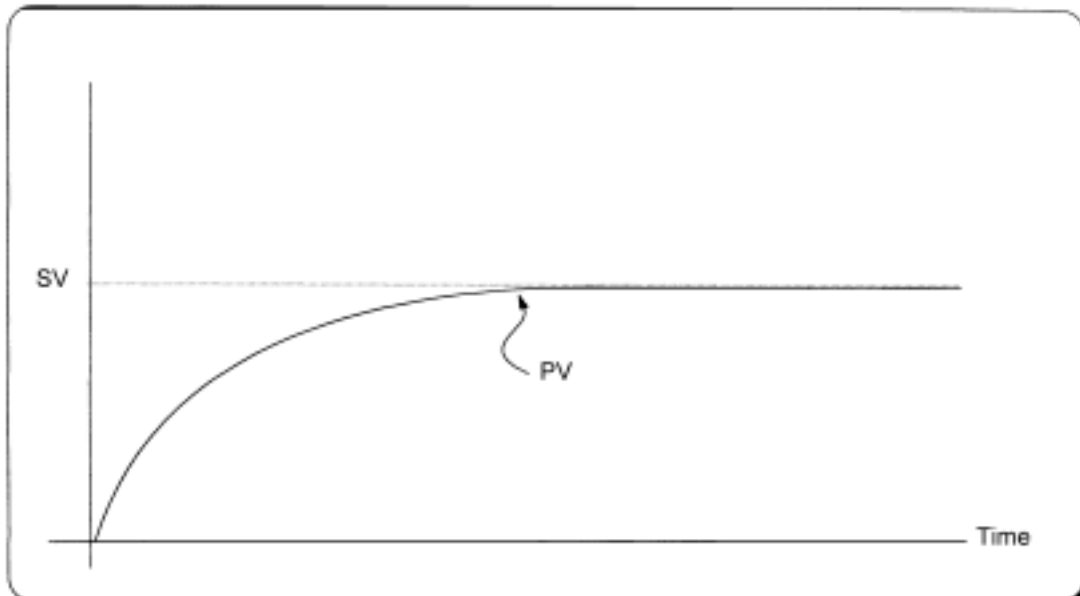

PID action in which P and D actions combine with I action.

Fig. 2.5 The system response when a long integration time given

Fig. 2.6 The system response when a short integration time given

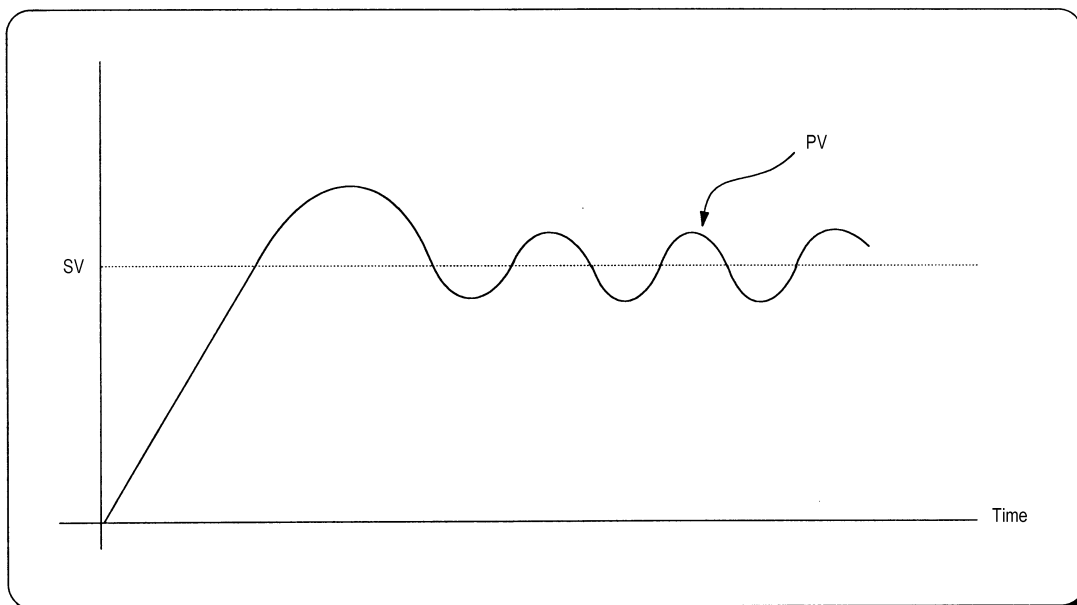

15.2.1.3 Derivative operation (D action)

- (1) When a deviation occurs due to alteration of SV or external disturbances, D action restrains the changes of the deviation by producing MV which is proportioned with the change velocity (a velocity whose deviation changes at every constant interval) in order to eliminate the deviation.
 - D action gives quick response to control action and has an effect to reduce swiftly the deviation by applying a large control action (in the direction that the deviation will be eliminated) at the earlier time that the deviation occurs.
 - D action can prevent the large changes of control object due to external conditions.
- (2) The period of time from when the deviation has occurred to when the MV of D action become the MV of P action is called derivative time and represented as K_d .
- (3) The D action when a constant deviation occurred is shown as Fig. 2.7.
 Fig. 2-7 Derivative action with a constant deviation
- (4) The expression of D action is as following;

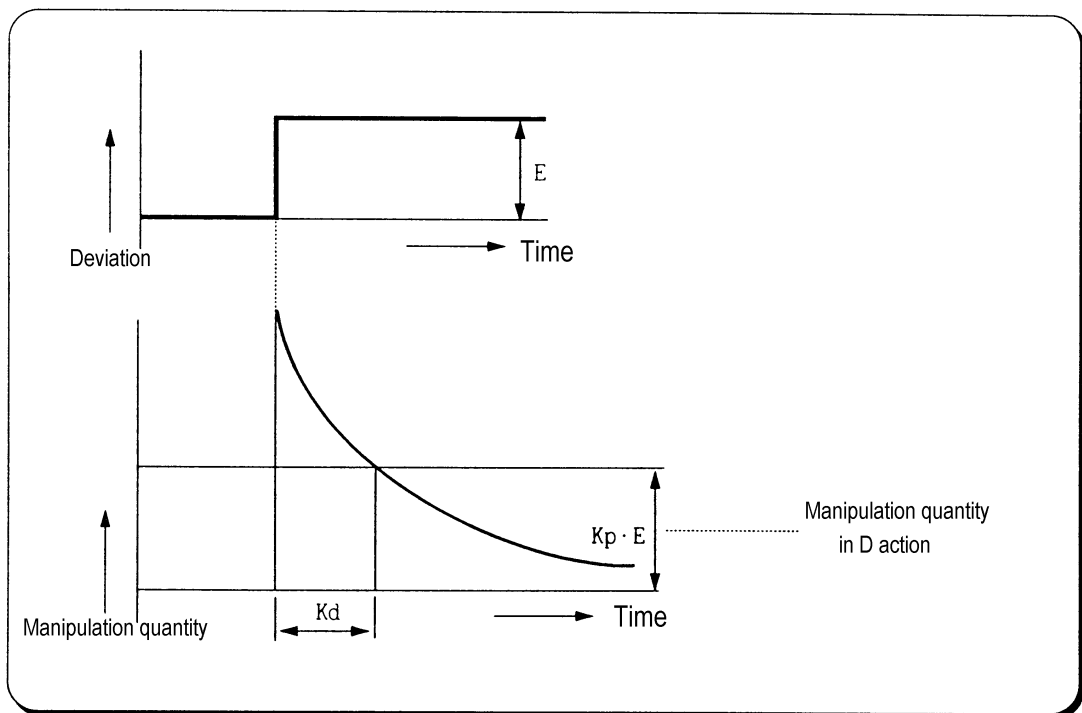

$$MV = K_p \times T_d \frac{dE}{dt}$$

- (5) Derivative action is used only in PID action in which P and I actions combine with D action.

15.2.1.4 PID action

- 1) PID action controls the control object with the manipulation quantity produced by (P+I+D) action
- 2) PID action when a given deviation has occurred is shown as the following Fig. 2.8.

Fig. 2-8 PID action with a constant deviation

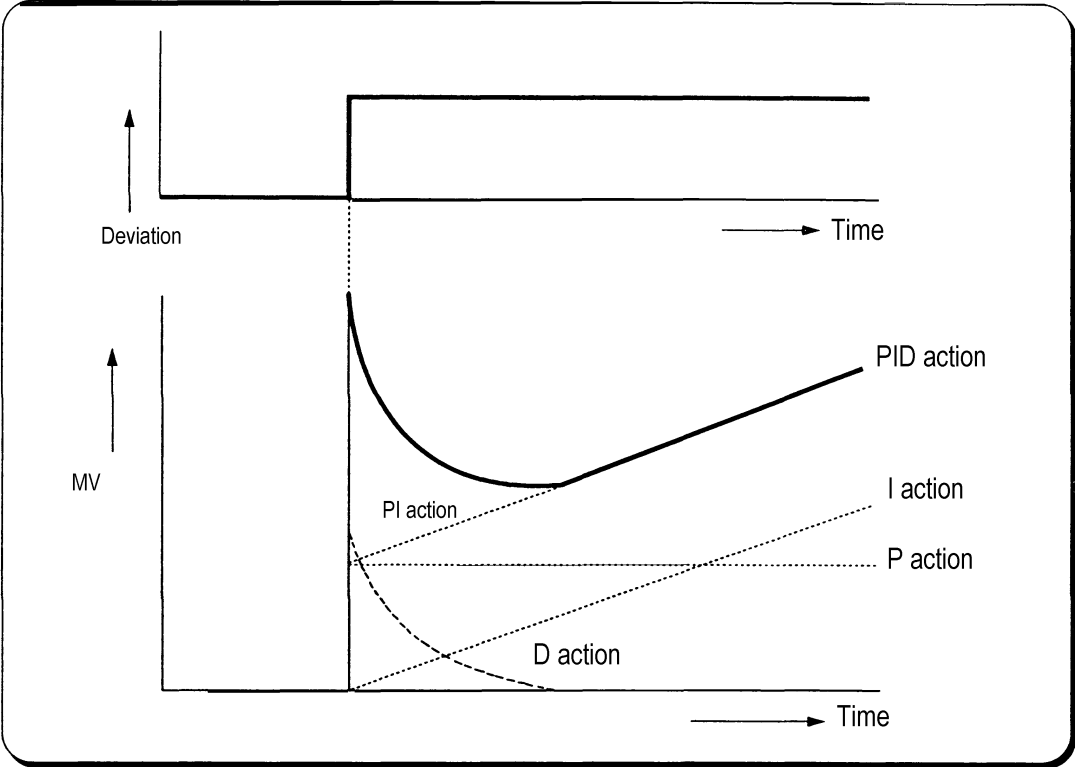

15.2.1.5 Forward / Reverse action

- 1) PID control has two kind of action, forward action and reverse action. The forward action makes the PV reaches to SV by outputting a positive MV when the PV is less than SV.
- 2) A diagram in which forward and reverse actions are drawn using MV, PV and SV is shown as Fig. 2.9.

Fig. 2-9 MV of forward / reverse action

- 3) Fig 2.10 shows examples of process control by forward and reverse actions,

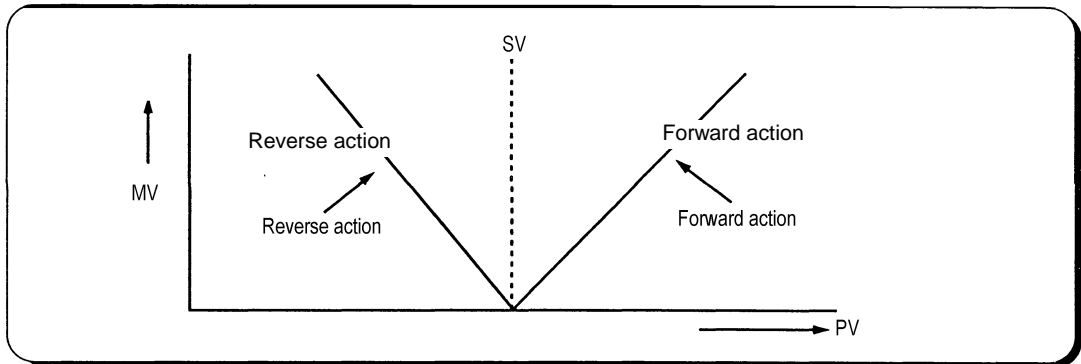

respectively.

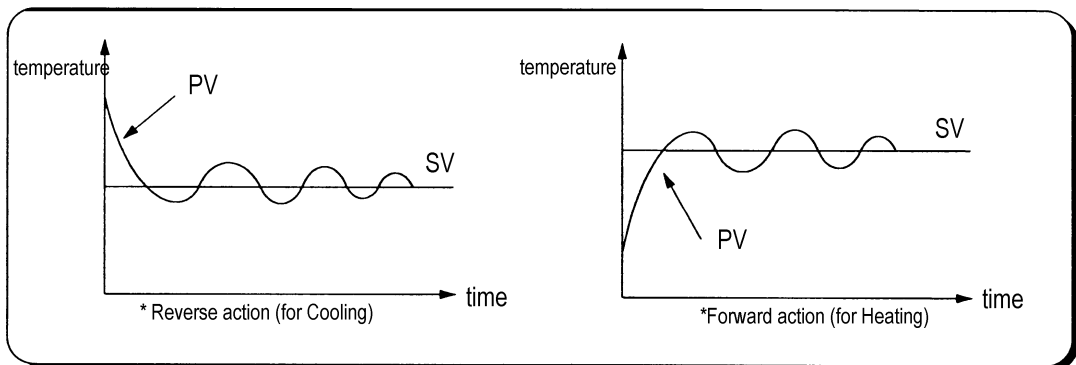

Fig. 2-10 PV of forward / reverse action

15.2.1.6 Reference value

In general feedback control system shown as the Figure 2-10, the deviation value is obtained by the difference of PV and SV. P, I, and D operations are performed based on this deviation value. However, each of P, I, and D operations use different deviation values according to the characteristics of each control actions. The expression of PID control is as following;

$$MV = K \left[Ep + \frac{1}{Ti} \int_0^t Ei(s)ds + Td \frac{dEd}{dt} \right]$$

- MV : Manipulate value
- K : Proportional gain
- Ti : Integral time
- Td : Derivative time
- Ep : Deviation value for proportional action
- Ei : Deviation value for integral action
- Ed : Deviation value for derivative action

The deviation values of P, I, and D action is described as following equations;

$$Ep = b \times SV - PV$$

$$Ei = SV - PV$$

$$Ed = -PV$$

The b of the first equation is called as reference value. It can be varied according to the load disturbance of measurement noise.

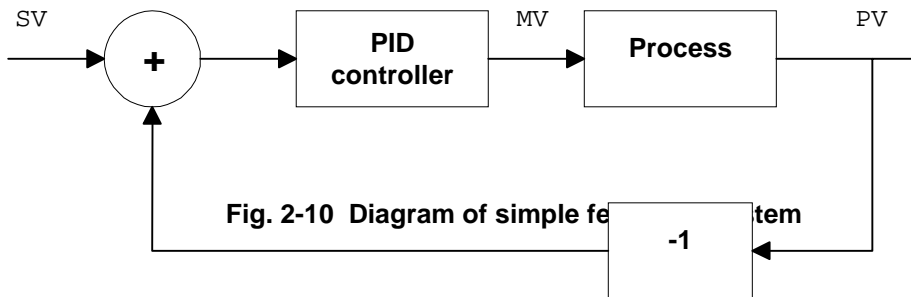

The figure 2.11 shows the variation of PV according to the several different reference values (b). As shown in the Fig. 2.11, the small reference value produces small deviation value, and it makes the control system response be slow.

In general, control system is required to be adaptable to various external / internal changes. Especially, it should shows a stable transient response with the sudden change of the SV to be robust to load disturbances and/or measurement noise.

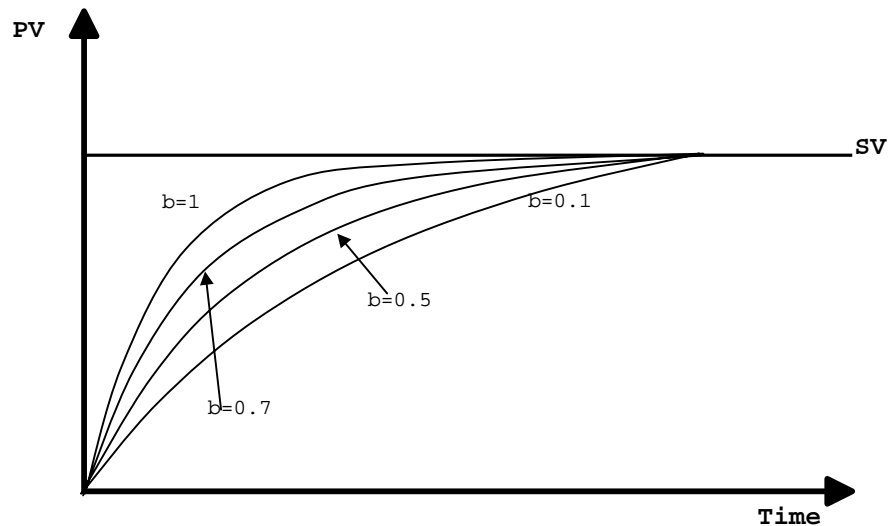

Figure 2-11 The PI control with several reference values

15.2.1.7 Integral windup

All devices to be controlled, actuator, has limitation of operation. The motor has speed limit, the valve can not flow over the maximum value. When the control system has wide PV range, the PV can be over the maximum output value of actuator. At this time, the actuator keeps the maximum output regardless the change of PV while the PV is over the maximum output value of actuator. It can shorten the lifetime of actuator.

When the I control action is used, the deviation term is integrated continuously. It makes the output of I control action very large, especially when the response characteristic of system is slow.

This situation that the output of actuator is saturated, is called as 'windup'. It takes a long time that the actuator returns to normal operating state after the windup was occurred.

The Fig. 2-12 shows the PV and MV of PI control system when the windup occurs. As shown as the Fig. 2-12, the actuator is saturated because of the large initial deviation. The integral term increase until the PV reaches to the SV (deviation = 0), and then start to decrease while the PV is larger than SV (deviation < 0). However, the MV keeps the saturated status until the integral term is small enough to cancel the windup of actuator. As the result of the windup, the actuator will output positive value for a while after the PV reached to the SV, and the system show a large overshoot. A large initial deviation, load disturbance, or mis-operation of devices can cause windup of actuator.

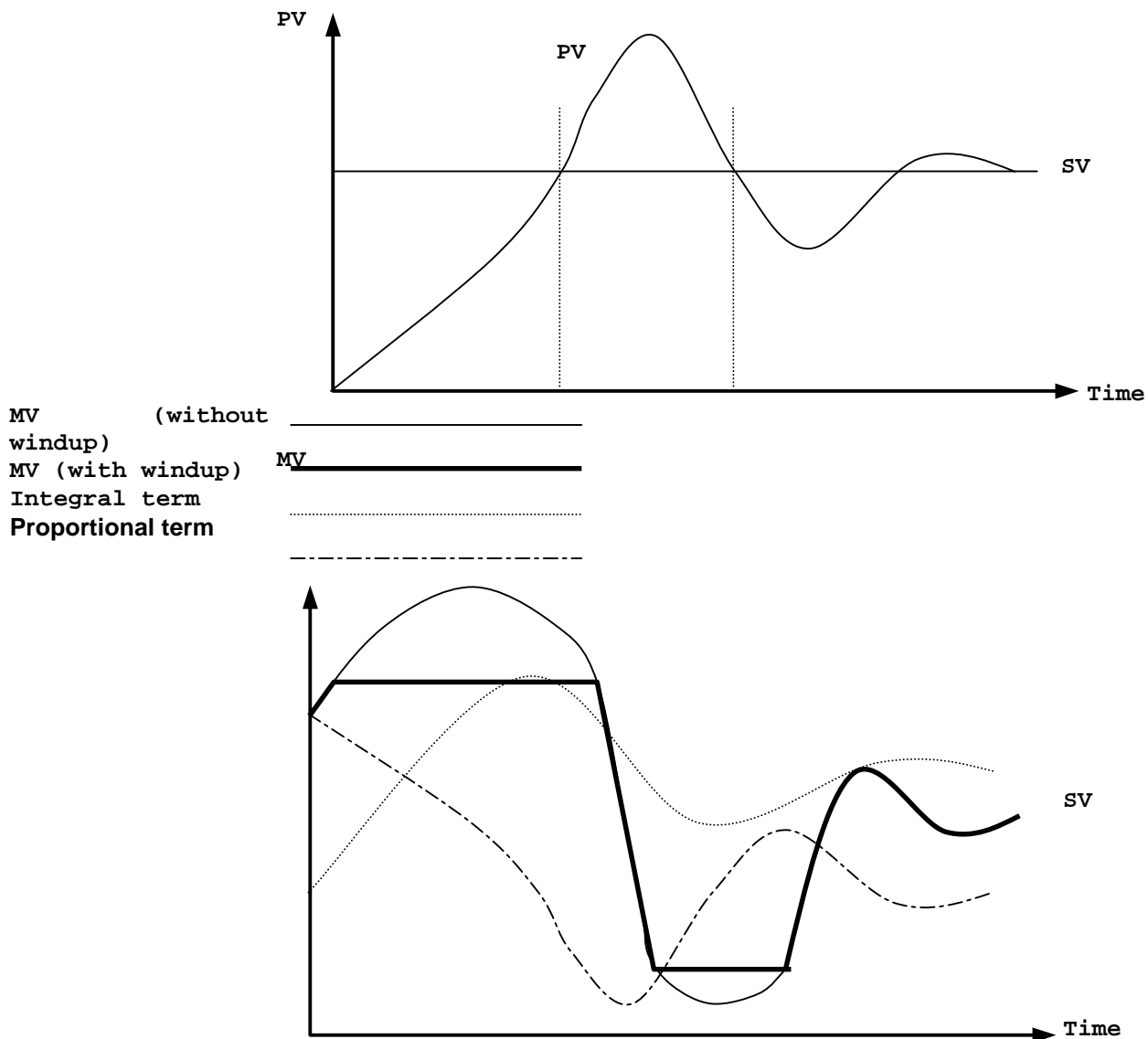

There are several methods to avoid the windup of actuator. The most popular two methods are adding another feedback system to actuator, and using the model of actuator. The Fig. 2-13 shows the block diagram of the anti-windup control system using the actuator model.

As shown in the Fig. 2-13, the anti-windup system feedback the multiplication of gain

($1/T_t$) and E_s to the input of integral term. The E_s is obtained as the difference value between actuator output (U) and manipulation value of PID controller (MV). The T_t of the feedback gain is tracking time constant, and it is in inverse proportion with the resetting speed of integral term. Smaller T_t will cancel the windup of actuator faster, but too small T_t can cause anti-windup operation in derivative operation. The Fig. 2-14 shows several T_t value and PV in the PI control system.

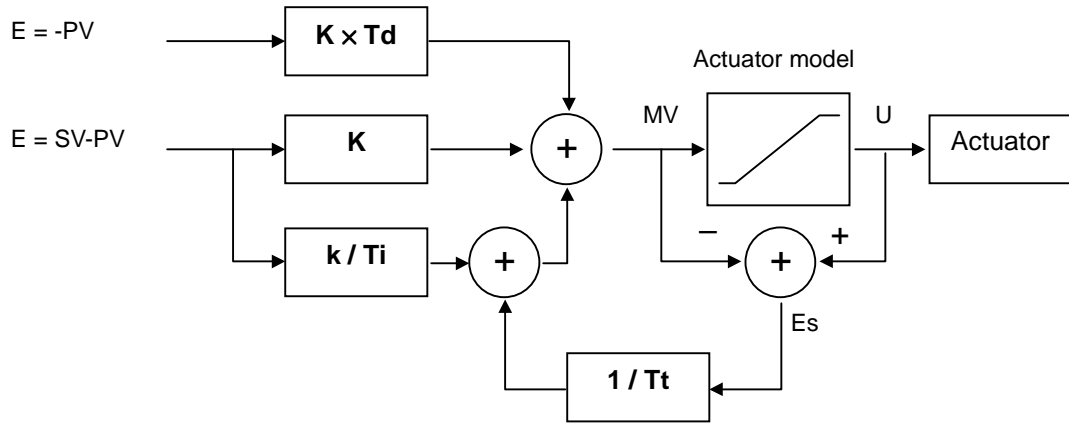

Fig. 2-13 The block diagram of anti-windup control system

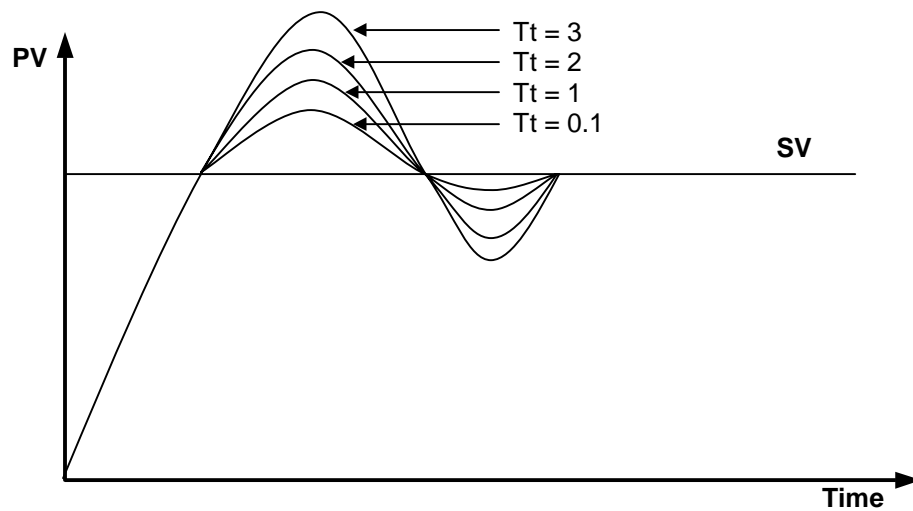

Fig. 2-14 The PV output characteristics with different T_t values.

15.2.2 Realization of PID control on the PLC

In this chapter, it will be described that how to get the digitized formula of the P, I, and D terms. Then, the pseudo code of PID control will be shown.

15.2.2.1 P control

The digitized formula of P control is as following;

$$P(n) = K[b \times SV(n) - PV(n)]$$

n : sampling number
K : proportional gain constant
b : reference value
SV : set value
PV : present value

15.2.2.2 I control

The continuous formula of I control is as following;

$$I(t) = \frac{K}{Ti} \int_0^t e(s) ds$$

I(t) : integral term

K : proportional gain constant
Ti : integral time
e(s) : deviation value

By deviation about t, we can obtain;

$$\frac{dI}{dt} = \frac{K}{Ti} e$$

e = (SV - PV) : deviation value

The digitized formula is as following;

$$\frac{I(n+1) - I(n)}{h} = \frac{K}{Ti} e(n)$$

h : sampling period

$$I(n+1) = I(n) + \frac{Kh}{Ti} e(n)$$

15.2.2.3 D control

The continuous formula of derivative term is as following;

$$\frac{Td}{N} \times \frac{d}{dt} D + D = -KTd \frac{dy}{dt}$$

N : high frequency noise depression ration
y : the object to be controlled (PV)

The digitized formula is as following (Use Tustin approximation method)

$$D(n) = \frac{2Td - hN}{2Td + hN} D(n-1) - \frac{2KTdN}{2Td + hN} [y(n) - y(n-1)]$$

15.2.2.4 Pseudo code of PID control

The pseudo code of PID control is as following;

Step 1 : Get constants that are used for PID operation

$$Bi = K \times \frac{h}{Ti} \quad : \text{integral gain}$$

$$Ad = \frac{(2 \times Td - N \times h)}{(2 \times Td + N \times h)} \quad : \text{derivation gain}$$

$$Bd = \frac{(2 \times K \times N \times Td)}{(2 \times Td + N \times h)}$$

$$A0 = \frac{h}{Tt} \quad : \text{anti-windup gain}$$

Step 2 : Read SV and PV value

$$PV = \text{adin}(\text{ch1})$$

Step 3: Calculate the proportional term.

$$P = K \times (b \times SV - PV)$$

Step 4 : Update the derivative term. (initial value of D = 0)

$$D = As \times D - Bd \times (PV - PV_old)$$

Step 5 : Calculate the MV. (initial value of I = 0)

$$MV = P + I + D$$

Step 6 : Check the actuator is saturated or not.

$$U = \text{sat}(MV, U_low, U_high)$$

Step 7 : Output the MV value to the D/A module

Step 8 : Update the integral term.

$$I = I + bi \times (SV - PV) + A0 \times (U - MV)$$

Step 9 : Update the PV_old value.

$$PV_old = PV$$

15.3 Function blocks

For the PID operation of GM6-CPUB and GM6-CPUC, following 2 function blocks are included in the GMWIN software. (version 3.2 or later)

No	Name	Description
1	PID6CAL	Perform the PID operation
2	PID6AT	Perform the auto tuning operation

Remarks

1. GM6-PID function blocks do not support array type.
2. Refer the GMWIN manual for the registration and running of function block.
3. GM6-CPUA does not support PID operation.

15.3.1 The function block for PID operation (PID6CAL)

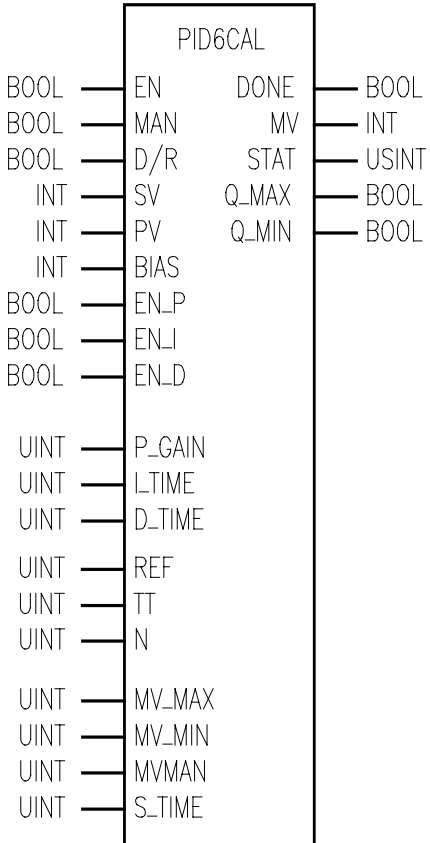
Function block	Description
 <p>The diagram shows a rectangular function block labeled 'PID6CAL'. On the left side, there are 20 input terminals with the following labels and data types: EN (BOOL), MAN (BOOL), D/R (BOOL), SV (INT), PV (INT), BIAS (INT), EN_P (BOOL), EN_I (BOOL), EN_D (BOOL), P_GAIN (UINT), LTIME (UINT), D.TIME (UINT), REF (UINT), TT (UINT), N (UINT), MV_MAX (UINT), MV_MIN (UINT), MVMAN (UINT), and S.TIME (UINT). On the right side, there are 5 output terminals with the following labels and data types: DONE (BOOL), MV (INT), STAT (USINT), Q_MAX (BOOL), and Q_MIN (BOOL).</p>	<p>Input</p> <p>EN : enable signal of the PID6CAL F/B MAN : manual operation mode (0 : auto, 1 : manual) D / R : select direction of operation (0 : forward, 1 : reverse) SV : set value data input (input range : 0 ~ 4000) PV : present value data input BIAS : feed forward or offset value input for disturbance compensation (input range : 0 ~ 4000) EN_P : enable signal of proportional control (0 : disable, 1 : enable) EN_I : enable signal of integral control (0 : disable, 1 : enable) EN_D : enable signal of derivative control (0 : disable, 1 : enable) P_GAIN : the proportional gain constant (range : 0.01 ~ 100.00) I_TIME : the integration time (range : 0.0 ~ 2000.0) D_TIME : the deviation time (range : 0.0 ~ 2000.0) MV_MAX : the maximum value of MV (range : 0 ~ 4000) MV_MIN : the minimum value of MV (range : 0 ~ 4000) MVMAN : the input data of manual operation mode (range : 0 ~ 4000) S_TIME : operation scan time (range : 0.1 ~ 10) REF : the reference value (range : 0.1 ~ 1) TT : tracking time constant (range : 0.01 ~ 10.00) N : high frequency noise depression ratio (range : 1 ~ 10)</p> <p>Output</p> <p>DONE : completion flag of PID operation MV : output manipulation value (range : 0 ~ 4000) STAT : error code output Q_MAX : shows MV is limited with maximum value Q_MIN : shows MV is limited with minimum value</p>

- 1) SV (setting value : the designated value) and PV (process value : present value) of GM6 PID operation have the range 0 ~ 4000. The range is set with the consideration of the resolution of A/D and D/A module of GM6 series (12 bits) and offset value.
- 2) The BIAS data is used for the compensation of offset in the proportional control.
- 3) In GM6-CPUB and GM6-CPUC, only the following 4 operation modes are available. Other operation modes, such as PD or I, are not permitted.

No.	EN_P	EN_I	EN_D	Operation
1	1 (enable)	0 (disable)	0 (disable)	P operation
2	1 (enable)	1 (enable)	0 (disable)	PI operation
3	1 (enable)	1 (enable)	1 (enable)	PID operation
4	0 (disable)	0 (disable)	0 (disable)	On/Off operation

- 4) The GM6 CPU module can handle only integer, not the floating point type. Therefore, to enhance the accuracy of PID operation, the PID6CAL function block is designed to input the P_GAIN data as the 100 times scaled up. For example, if the designated P_GAIN is 98, actual input data of P_GAIN should be 9800. If the designated P_GAIN is 10.99, input 1099 to the P_GAIN.
- 5) I_TIME and D_TIME are 10 times scaled up. For example, input 18894 if the designated I_TIME value is 1889.4. The range of actual input is 0 ~ 20000.
- 6) S_TIME is the period of reading data (sampling), and also 10 times scaled up. Generally, it should be synchronized with external trigger input (EN input of function block) to perform proper PID operation. The range of sampling time is 0.1 ~ 10 seconds, and actual input range is 0 ~ 100.
- 7) REF may be useful parameter according to the control system type, especially velocity, pressure, or flux control system. The REF input is also 10 times scaled up, and the actual range is 0 ~ 10.
- 8) TT (tracking time constant) parameter is used to cancel anti-windup operation. The range of TT is 0.01 ~ 10 and the actual input range that are 100 times scaled up is 0 ~ 1000.
- 9) N (high frequency noise depression ratio) parameter is used for derivative control operation, and shows the ratio of high frequency noise depression. If there is a lot of high frequency noise in the control system, select the N value as higher value. Otherwise, leave the N parameter as 1. The range of N is 0 ~ 10 and it is not scaled up, so input the designated value directly.

15.3.2 The error code of PID6CAL F/B

The following table shows error codes and descriptions of PID6CAL function block.

Error code (STAT output)	Type	Description	Countermeasure
0	Local	Normal operation	
1		SV is out of range	Change the SV within 0 ~ 4000
2		MVMAN is out of range	Change the MVMAN within 0 ~ 4000
3		P_GAIN is out of range	Change the P_GAIN within 0 ~ 10000
4		I_TIME is out of range	Change the I_TIME within 0 ~ 20000
5		D_TIME is out of range	Change the D_TIME within 0 ~ 20000

Chapter 15. The PID functions

6		S_TIME is out of range	Change the S_TIME within 0 ~ 100
7		REF is out of range	Change the REF within 0 ~ 10
8		TT is out of range	Change the TT within 0 ~ 1000
9		N is out of range	Change the N within 0 ~ 1000
10		EN_I and/or EN_D is set as 1 when EN_P is 0	Only P, PI, and PID controls are available with GM6-CPUB and GM6-CPUC. Please change the setting of EN_P, EN_I, and EN_D by reference to the chapter 15.3.1.
40		CPU type is mismatched	Replace the CPU module with GM6-CPUB or GM6-CPUC.

Remarks

1. Please be careful to input 100 times scaled up values for P_GAIN and TT.
2. I_TIME, D_TIME, S_TIME, and REF are 10 times scaled up, not 100 times.

15.3.3 Auto tuning function block (PID6AT)

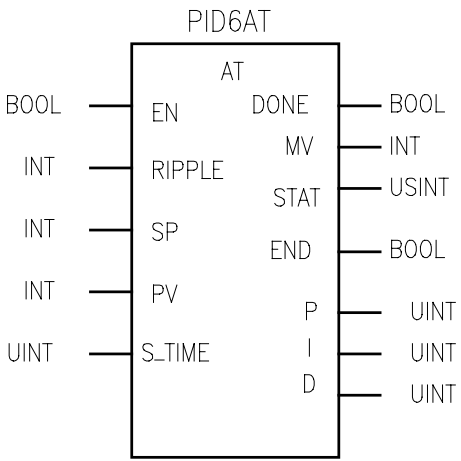
Function block	Description
	<p>Input</p> <p>EN : enable input of function block</p> <p>SV : set value (goal value) data input (range : 0 ~ 4000)</p> <p>PV : present value input (range : 0 ~ 4000)</p> <p>S_TIME : scan time input (sampling interval) (range : 0 ~ 100)</p> <p>RIPPLE : select the wave form to be used for auto tuning operation. Select 1 in general case.</p> <p>Output</p> <p>DONE : Turn on whenever the auto tuning operation is completed.</p> <p>END : Turns on when the F/B operation is completed with no error, and keep the status until next F/B execution</p> <p>STAT : shows the error code</p> <p>MV : the manipulated value of current loop on which the auto tuning operation is performed. (range : 0 ~ 4000)</p> <p>P : the proportional gain constant obtained by auto tuning operation. (range : 0.01 ~ 100.00)</p> <p>I : the integral time constant obtained by auto tuning operation.</p> <p>D : the derivative time constant obtained by auto tuning operation</p>

- 1) SV (setting value : the designated value) and PV (process value : present value) of GM6 PID operation have the range 0 ~ 4000. The range is set with the consideration of the resolution of A/D and D/A module of GM6 series (12 bits) and offset value. When setting the SV or PV, please be careful convert the analog value of control object (temperature, velocity, etc.) to digital value that are the output of A/D convert module. For example, assume that PID control is used for temperature control with Pt100 (operation range : 0 °C ~ 250 °C), and the goal value is 100 °C. The equivalent digital output of A/D module (voltage output range : 1 ~ 5V) is 1600 if the A/D module outputs 0 (1V) with 0 °C, and 4000(5V) with 250 °C. Therefore, the input of SV should be 1600, not 2.
- 2) S_TIME is the period of reading data (sampling), and 10 times scaled up for more precious operation. Generally, it should be synchronized with external trigger input (EN input of function block) to perform proper PID operation. The range of sampling time is 0.1 ~ 10 seconds, and actual input range is 0 ~ 100.
- 3) The GM6-CPUB and GM6-CPUC module perform auto-tuning operation based on the frequency response method. PID parameters are obtained by On/Off operation during 1 cycle of PV variation. The RIPPLE parameter shows at which cycle the CPU module will perform auto-tuning operation. If 0 is selected, the CPU will get PID parameters during the first cycle of PV variation. If 1 is selected, the second cycle will be used. (refer Fig. 12-15 for detailed information) Other choice of RIPPLE parameter is not allowed. In general case, select 1 for proper auto-tuning operation. The On/Off operation will be occur at the 80% of PV value.

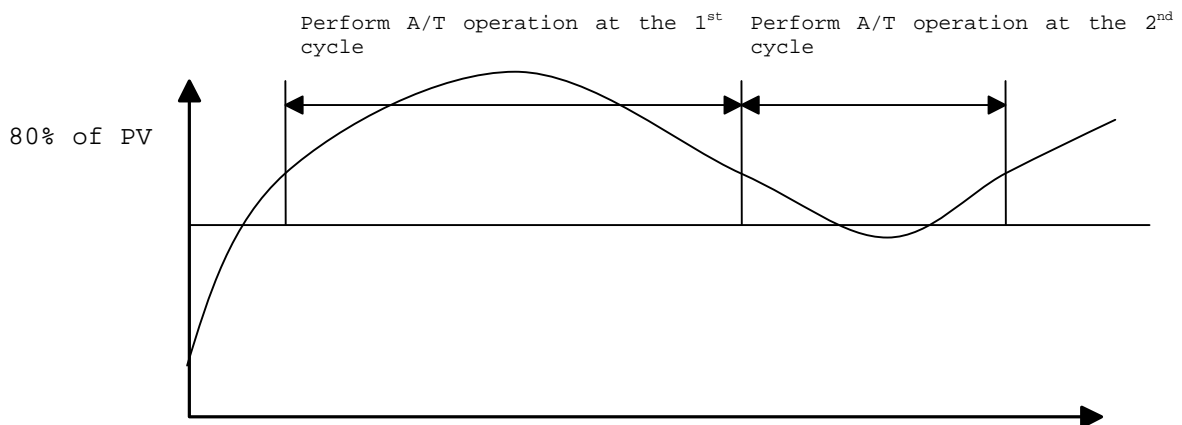

15.3.4 Error codes of auto-tuning function block (PID6AT)

The following table shows error codes and descriptions of PID6AT function block.

Error code (STAT output)	Type	Description	Countermeasure
0	Local	Normal operation	
1		SV is out of range	Change the SV within 0 ~ 4000
2		PV is out of range	It may caused by fault of A/D module. Check the A/D module.
3		S_TIME is out of range	Change the S_TIME within 0 ~ 100
4		CPU type is mismatched	Replace the CPU module with GM6-CPUB or GM6-CPUC.

15.4 Programming

15.4.1 System configuration

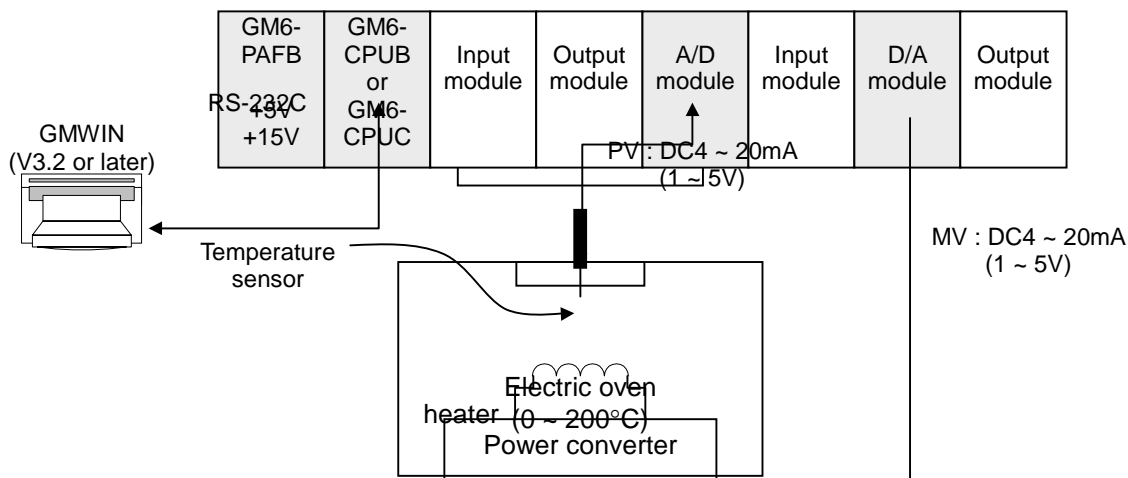

15.4.2 Initial setting

- 1) PID operation parameters
 - a) Auto / Manual operation setting : Auto
 - b) Forward / Reverse operation : Forward
 - c) SV setting : 1600 (100°C)
 - d) BIAS setting : 0 (If only P control is used, input proper value other 0)
 - e) EN_P, EN_I, EN_D setting : EN_P=1, EN_I=1, EN_D=1 (PID operation)
 - f) REF, TT, N : REF=10, TT=5-, N=1
 - g) MV_MAX, MV_MIN, MVMAN : MV_MAX=4000, MC_MIN=0, MAMAN=2000
 - h) S_TIME : S_TIME=100 (sampling time = 10 seconds)
- 2) Auto-tuning parameters
 - a) PV setting : 1600 (100°C)
 - b) S_TIME : S_TIME=100 (sampling time = 10 seconds)

- 3) A/D module setting
 - a) Channel setting : use channel 0
 - b) Output data type : - 48 ~ 4047
 - c) Input processing : Sampling
- 4) D/A module setting
 - a) Channel setting : use channel 0

15.4.3 Program description

15.4.3.1 Use only PID operation (without A/T function)

- 1) Convert the measured temperature (0 ~ 250°C) to current signal (4 ~ 20mA), and input the current signal to the channel 0 of A/D module. Then, the A/D module converts the analog signal to digital value (0 ~ 4000)
- 2) PID6CAL function block will calculate manipulate value (MV : 0 ~ 4000) based on PID parameter settings (P_GAIN, I_TIME, D_TIME, etc.) and PV from A/D module. Then, the calculated MV is output to the channel 0 of D/A module.
- 3) D/A module will convert the MV (0 ~ 4000) to analog signal (4 ~ 20mA) and output to the actuator (power converter).

15.4.3.2 Use PID operation with A/T function

- 1) Convert the measured temperature (0 ~ 250°C) to current signal (4 ~ 20mA), and input the current signal to the channel 0 of A/D module. Then, the A/D module converts the analog signal to digital value (0 ~ 4000)
- 2) A/T function block will calculate manipulate value (MV : 0 ~ 4000) based on the SV and PV from A/D module. Simultaneously, the A/T module will calculate P,I and D parameters.
- 3) The END output of A/T module will be 1 when the A/T operation is completed. Then, PID module will start operation with PID parameters that are calculated by A/T module.
- 4) D/A module will convert the MV (0 ~ 4000) to analog signal (4 ~ 20mA) and output to the actuator (power converter).

Chapter 15. The PID functions

[Example program of 15.4.3.1]

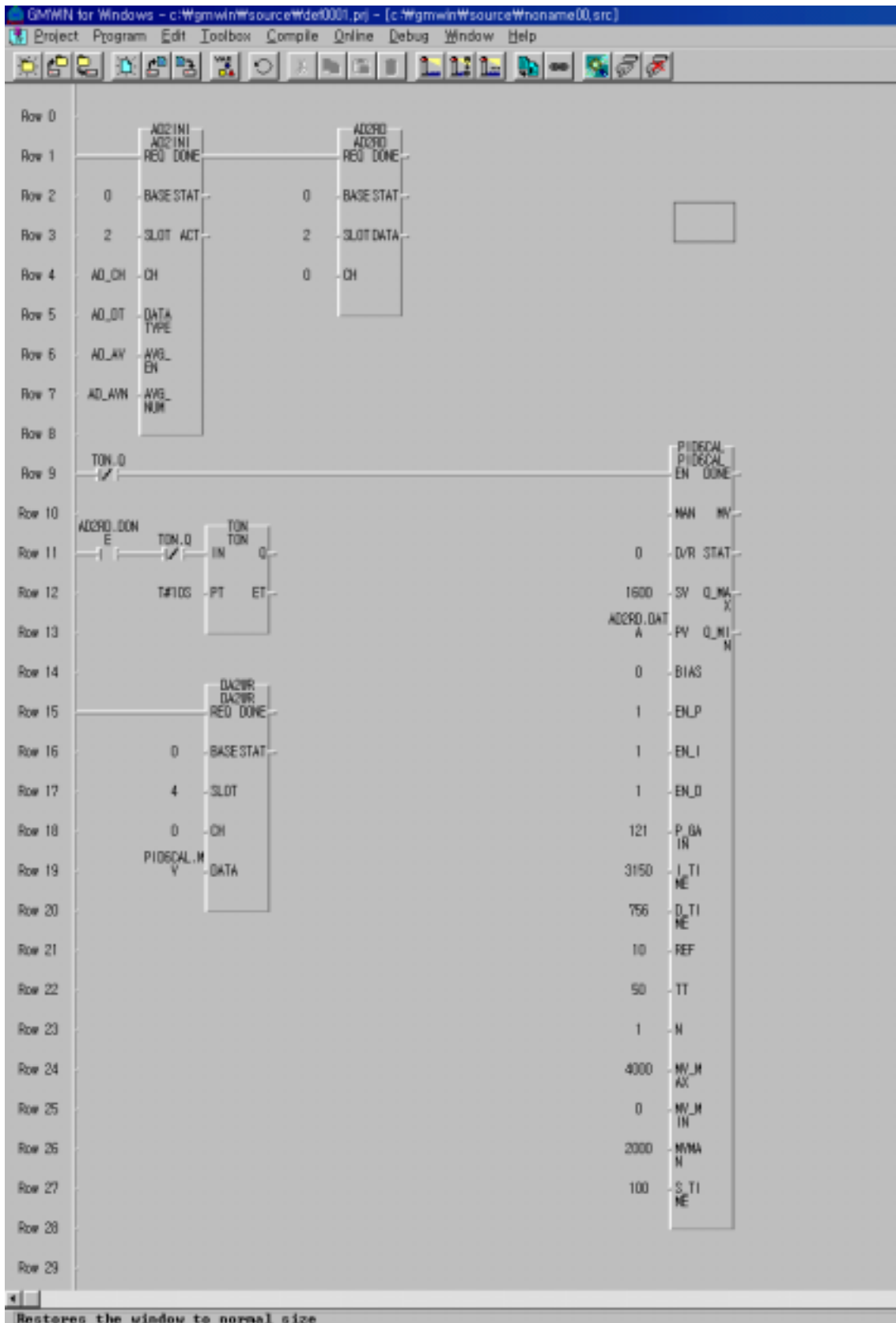

[Example program of 15.4.3.2]

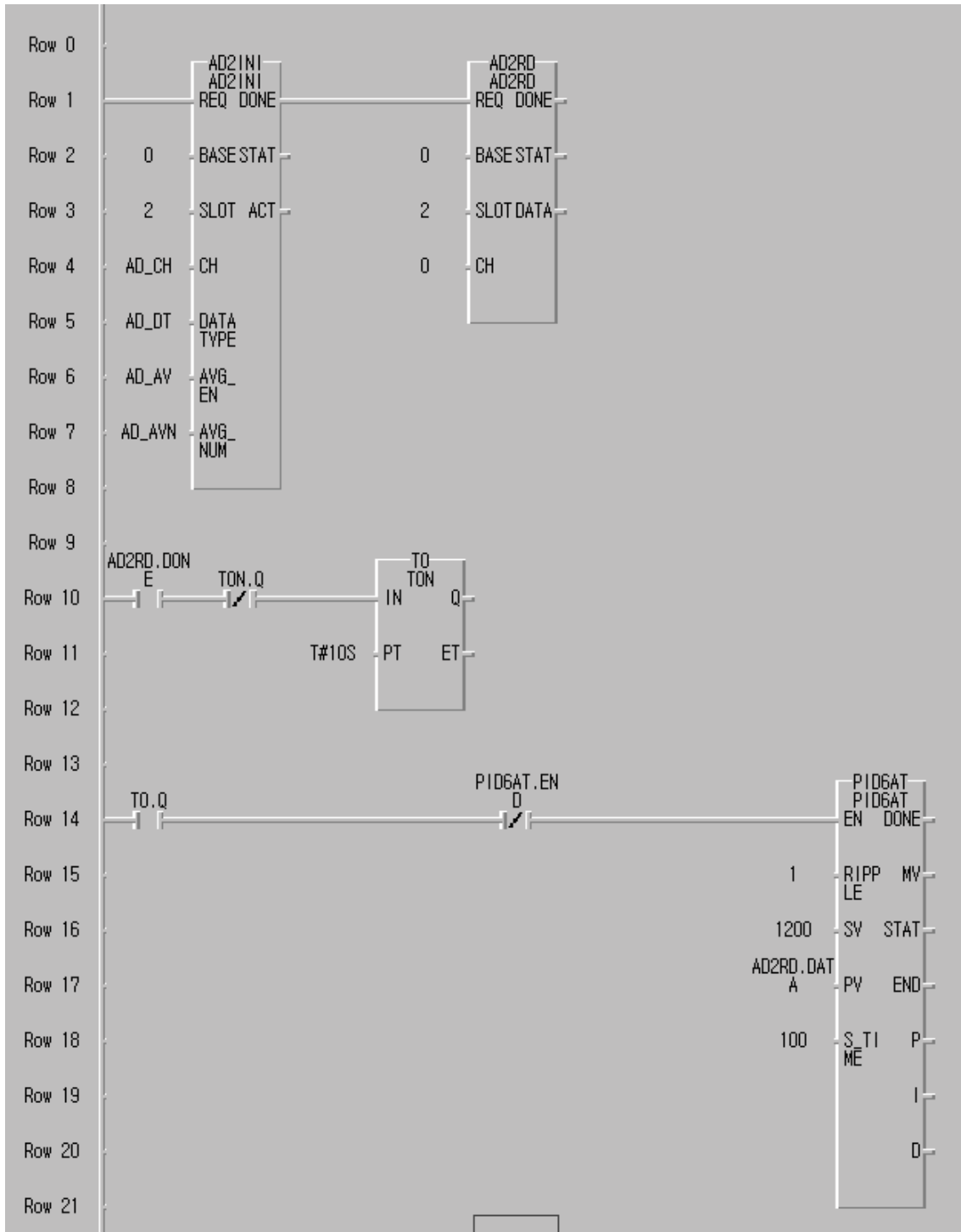

(continue to next page)

