

Chapter 5. PROGRAMMING

5.1 Programming for Controlling Inverter Speed with 5 Step Analog Output Voltage

1) System Configuration

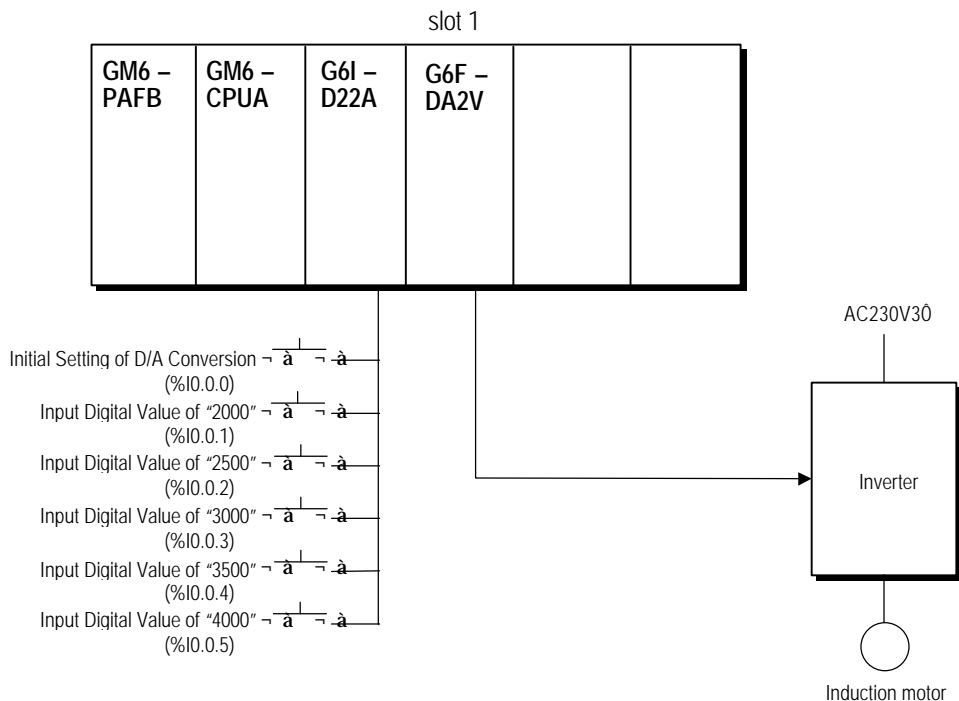

2) Initial Settings

- (1) Enabled channel : channel 0

3) Descriptions of the Program

- (1) %I0.0.0 turning On leads to write digital value to D/A conversion module.
- (2) %I0.0.1 turning On leads to output of "2000"(0 V) on channel 0.
- (3) %I0.0.2 turning On leads to output of "2500"(2.5 V) on channel 0
- (4) %I0.0.3 turning On leads to output of "3000"(5 V) on channel 0.
- (5) %I0.0.4 turning On leads to output of "3500"(7.5 V) on channel 0.
- (6) %I0.0.5 turning On leads to output of "4000"(10 V) on channel 0.

4) Program

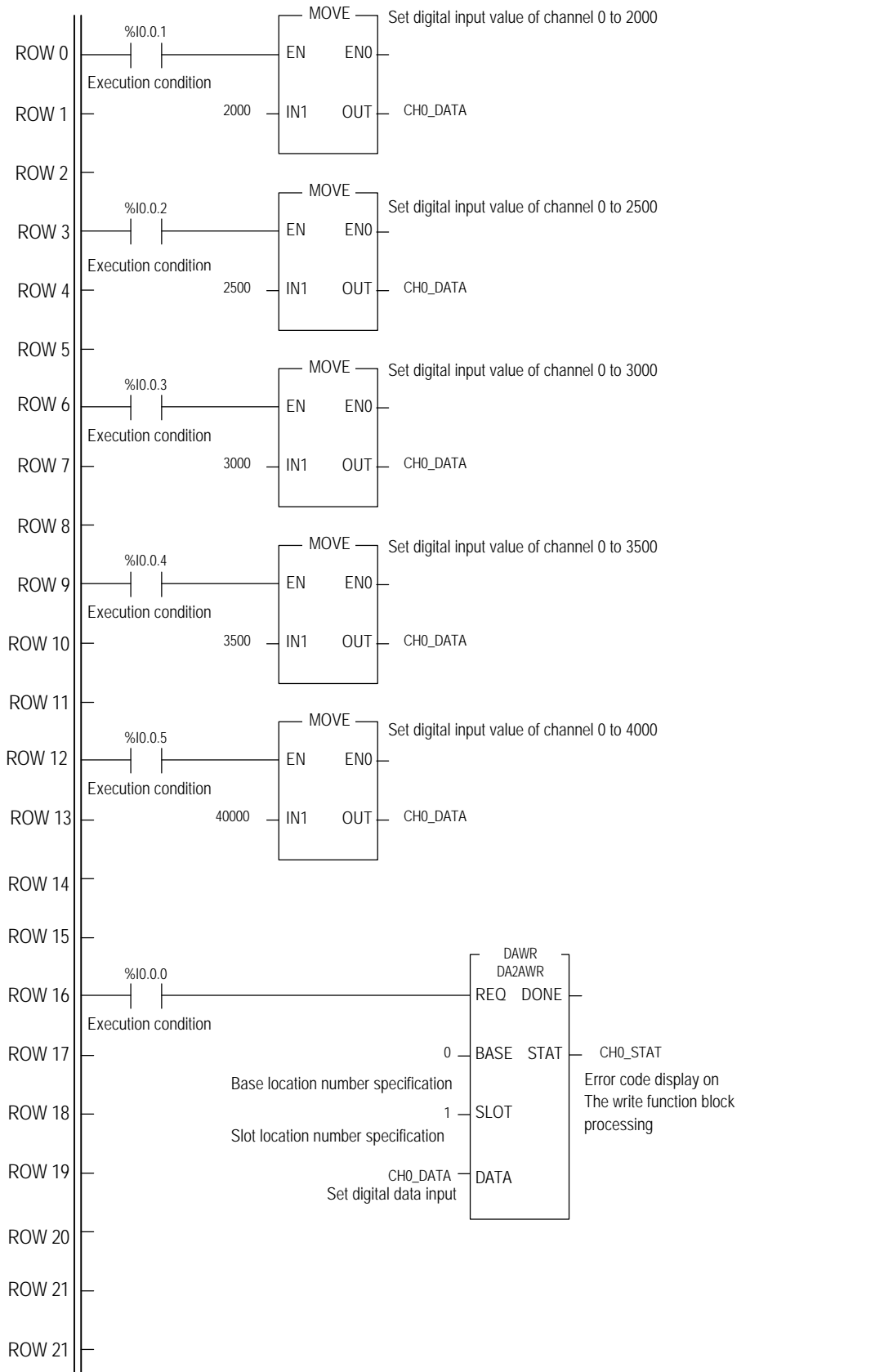

5) Digital value setting of I/O Variables

Add/Edit Variables

Variable Name : CHO_DATA

Variable Kind : VAR

Data Type : Array (0.. 3) OF INT

Memory Allocation : Auto

Init. Array...

This denotes 4 channels

Select this and this screen appears

Initialize Array

Array Name : CHO_DATA : ARRAY [0..3] OF INT

Initialize

[0]	0
[1]	0
[2]	0
[3]	0

Channel No.

Digital Value

To Select previous Ch.

To Select next Ch.

Initialize Array Element

Array Element Name : CHO_DATA[0]

Initial Value : 0

Set digital data input

6) I/O Variables on Program

Variable name	Var_Kind	Data Type	(AT Address) (Initial Value)
CH0_DATA	: VAR	: ARRAY[0..3] OF INT	: = {0,0,0,0}
CH0_STAT	: VAR	: USINT	
DAWR	: VAR	: FB Instance	

5.2 Programming for Displaying D/A Conversions which is Set by Digital Switch

1) System Configuration

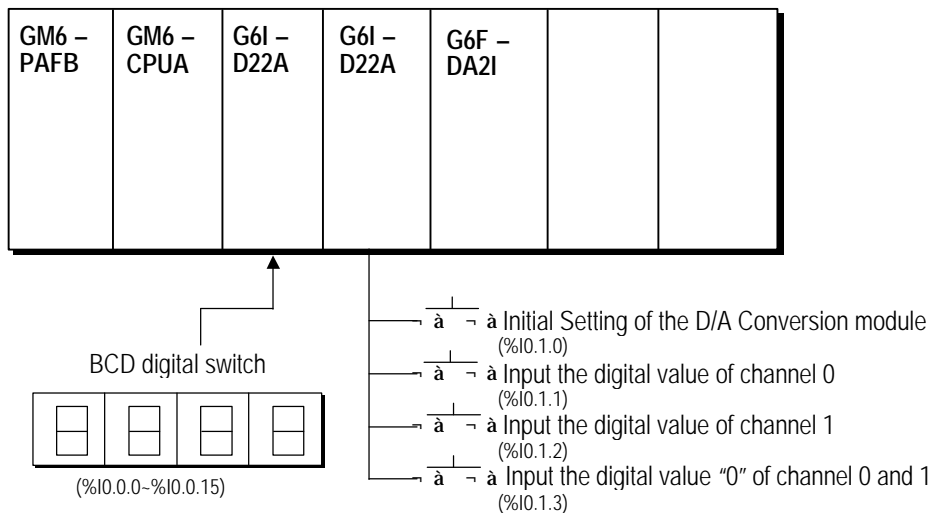

2) Initial Settings

(1) Enabled channel : channel 0, 1

3) Descriptions of the Program

- (1) %I0.1.0 turning On leads to write the digital value to D/A conversion module.
- (2) %I0.1.1 turning On leads to output of the values by digital switch on channel 0 of D/A module.
- (3) %I0.1.2 turning On leads to output on channel 1.
- (4) %I0.1.3 turning On leads to initialization of digital input value to "0" on channel 0 and channel 1.

4) Program

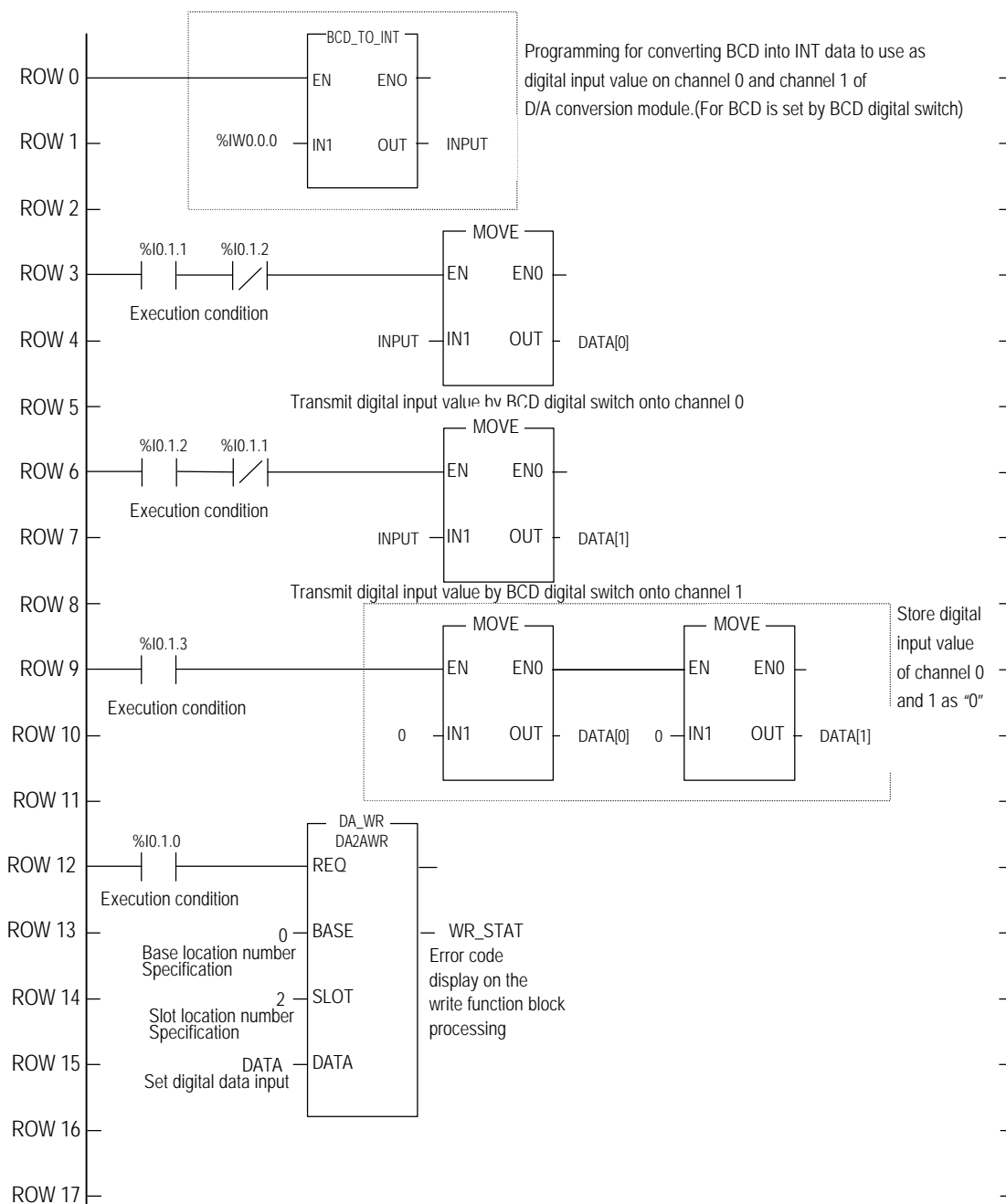

5) I/O Variables on Program

Variable name	Var_Kind	Data Type	(AT Address) (Initial Value)
INPUT	: VAR	: DINT	
OUTPUT	: VAR	: INT	
DA_WR	: VAR	: FB Instance	
WR_STAT	: VAR	: USINT	
DATA	: VAR	: ARRAY[0..3] OF INT	: = {0,0,0,0}