

1. Overview

1-1 Introduction

1-1-1. Definition

This User's manual describes the specifications, handling, utility functions and other information of PMU-200 Programmable Monitoring Unit.

PMU-200 is the operating panel with function key to replace originally used operation panel such as switch operations, displays of data, lamps and messages. It makes user realize CIM (Computer Integrated Manufacture) easily using FA monitoring equipment like PMU series.

1-1-2. Features

- 1) Windows based software package for screen editing
(Windows 3.1, Windows 95)
 - Project Manager
 - Screen Editors: Main and Sub Screen Editor
 - Symbol Editor, Alarm Editor, Message Editor and Link Editor
- 2) Simulation to debug screen editing without connecting PLC and/or PMU main unit
The graphic software supports simulation function how the screen is operating well.
So, a user can debug the screen simply without any connection between PLC or PMU main unit.
- 3) Various Interfaces for other PLCs
 - Serial interface(RS232C/RS422)
 - LG PLCs(-G SeriesK Series)
 - Fuji PLCs-(MICREX series)
 - Mitsubishi PLCs-(MELSEC series)
 - OMRON PLCs (SYSMAC series)
 - Matsushita PLCs(FARA series)
 - AB PLCs-(PLC-5/SLC-500 series with DF1 protocol)
 - Modicon PLCs-(Quantum series with Modbus protocol)
 - LG Inverters

*1 Windows is a registered trademark of Microsoft Corporation.

- High speed communications
Data Link : Master-K series, FAM(Factory Automation Manager)
- User defined Protocol communication

- 4) Display components
LCD-MONO (B/W, BLUE)

- 5) Abundant Diagnosis
 - Function Key check
 - Font check,
 - Check of OS(Operating System) area of internal memory
 - Alarm history check
 - CPU communication check

- 6) Easy interface for user
User defined Function keys (F1 ~ F10 / 0 ~ 9 , SHIFT, MENU , ENT , UP , DOWN, LEFT, RIGHT)

1-2. Hardware Structure

1-2-1. Partial Names and Functions

A	Display	Components : B/W LCD, Blue LCD Screen : 240 x 128 dot
B	Function Keys	F0 ~ F9 : User defined function keys, SHIFT, MENU, ENT,LEFT, RIGHT, UP, DOWN
C	Power LED	Power ON mode
D	T/F LED	ON: Ten-Key Mode OFF: Function Key Mode
E	Run LED	Run Mode
F	Power Supply Terminal	DC24V(+24V, GND, NONE)
H	Auxiliary I/O ports	8 Outputs, 3 Special function outputs, 3 Inputs
I	RS232C port	Serial port(9pin port)
J	RS422 port	SD+,SD-,RD+,RD-SG,FG
K	DLU port	Data Link Communication port for LG-Master K series

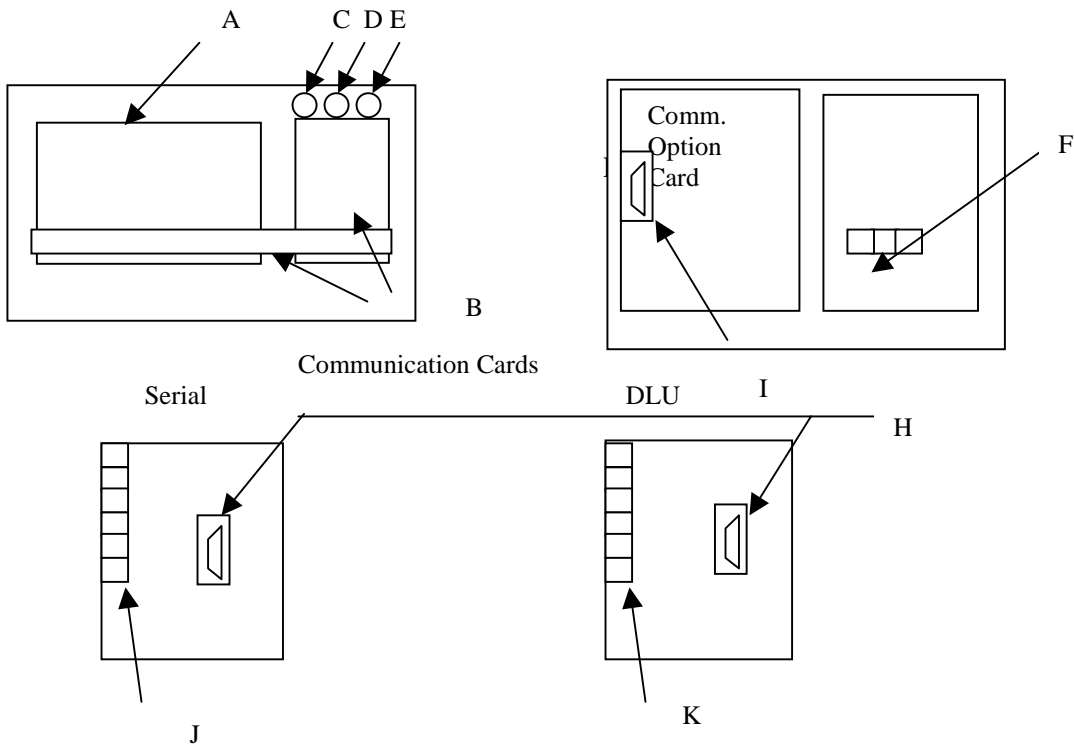

Special Function Keys(16 Keys)

MENU	To cancel a mode in the execution of menu, To go back to the previous mode or step Can select Ten-key mode or Function Key mode by toggle switch in the Main Unit
F1~F5	In Run Mode, F1: Call previous screen F2: Call original screen F3: S/W Reset F4: Exit Run mode F5: Alarm list
ENT	In edit mode : to enter data or execute some mode In Ten-Key Mode : to enter key data In Function Mode : For Function keys
↑	In edit mode : Up key In Run mode : For Function Keys
↓	In edit mode : Down key In Run mode : For Function Keys
0 ~9	In Run mode, In Ten-Key Mode : Key values In Function Key Mode : Function keys

1-2-2. System Configuration

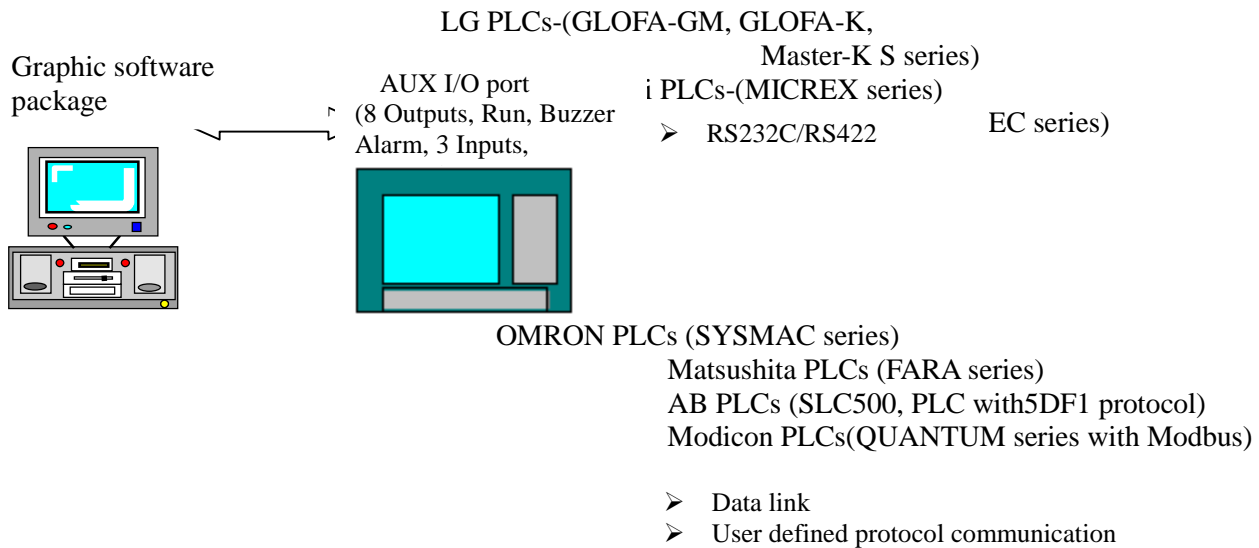

1-3. Procedures to prepare for starting operation

Procedure for editing screen in PC based software and PMU main unit.

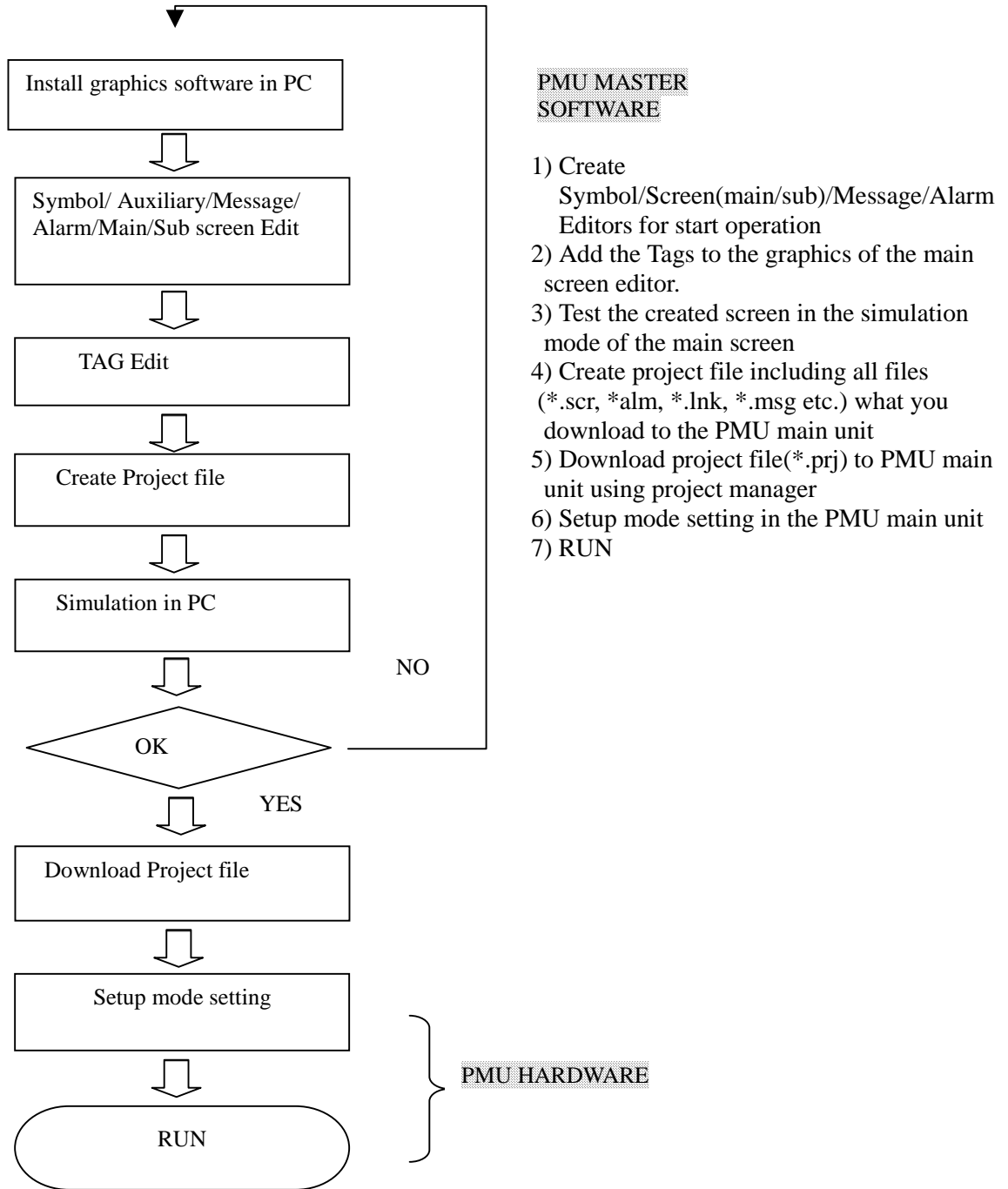

1-4. Types of Tag functions

Functions	Contents
N Tag (Numeric Tag)	This function displays data stored in word devices of PLC
A Tag (Auxiliary Tag)	This function displays graphics or messages from the already created sub-screen onto the main screen.
S Tag (Symbol Tag)	This function displays the already created symbols from symbol Editor onto the main screen.
V Tag(Key indicator Tag)	This function makes the numeric values by a key tag displayed onto the screen. It also should be saved as after sub-screen number 900(ex:900.sub)
G Tag(Graph Tag)	This function displays the data stored in word devices as a bar or closed line.
F Tag(Function key Tag)	This function can use 12 function keys of PMU main unit. This function writes specified value to a word device or turns on a specified bit device when a function key is pressed. User defines them.
W Tag(Buffer write Tag)	This function writes specified data or bit to a designated system buffer.
D Tag(Delay Tag)	According to the operating condition, it writes specified value or turns on A specified bit device after the designated timer is On.
M Tag(Message Tag)	This function enables designated message from the message editor to be displayed as bit or word devices are turned on or off.
L Tag(Lamp Tag)	This turns lamps on and off in conjunction with bit devices being turned on and off from PLC. Lamp color can be changed to any of colors.
C Tag(Computation Tag)	This function enables data computed by condition to be entered into the specified buffer.
Q Tag(String Tag)	This function writes data from PLC as a string of ASCII code.

2. Specifications

2-1. General specifications

Items	LCD Type
Input power(Voltage)	DC 24V (Min. 20 V~ Max. 28V)
Power consumption	Less than 20VA
Noise withstand resistance	Impulse noise voltage : 900Vp-p/□
Insulation resistance	10MΩ at DC 500V
Ambient operating temperature	0~40□
Ambient storage temperature	-20~70□
Ambient operating humidity	40□, 85%RH
Ambient storage humidity	40□, 85%RH
Environment	No corrosive gases
Vibration endurance	10 to 25 Hz(X,Y,Z direction 2G 30 minutes)

2-2. Performance specifications

Items	Specifications
Display component	B/W LCD, Blue LCD
Resolution	240 x 128 Dots
Display properties	Normal, Toggle, Blink
Text enlargement	1~8 times(width x height each)
Types of graphics	Line, rectangle, Circle, Oval, Painted rectangle, Painted Circle, Painted Oval, Text, Clock
Type of graph	Bar graph
Screen numbers	999 (main/sub/symbol/alarm/message each)
Auxiliary I/O ports	1 Inputs(DI points), 2 Outputs(DO points)
Communication Interface	RS232C/RS422, Datalink
Function keys(Hardware)	SHIFT, MENU,ENTER, F0~F9, UP,DOWN,LEFT,RIGHT

2-3. Auxiliary I/O Specifications

2-3-1. Input Specification

Items	Specifications	
Input points	1 points(Data 1 point)	
Rated input voltage	DC24V(DC19.2 ~ DC30V:-15/20%)	
Input Current	10mA	
Delay time	ON	10mA
	OFF	15mA
Common	Input data common(DC24V+), Switch Input common(DC 24+)	
Insulation method	Photo-coupler insulated	
External connection	Connector type	

2-3-2. Output Specification

Items	Specifications	
Output points	2 points(Data :2 points)	
Rated input voltage	DC24V(DC19.2 ~ DC30V:-15/20%)	
Output Current	10mA	
Delay time	ON	Less than 1msec
	OFF	Less than 1msec
Common	GND	
Insulation method	Photo-coupler insulated	
External connection	Connector type	

2-3-3. Auxiliary I/O pin assignment

Pin No.	Signal	Contents
1	SWCOMM(24V)	Input common (24V)
2	DO(0)	Data output
3	DO(1)	Data output
4	SI(0).	Data Input
5	DICOMM	Output common (GND)

2-4. Communication Specification

2-4-1. Datalink Communication

- Baud rate : 1 M bps
- PLC connection and PMU station number
 - Connectable up to Max. 32 PMUs
 - Station number: 1 ~ 125 stations
- The number of words to be connected per station
 - Remote I/O: Send: max. 32 words, Receive: :max. 32 words
 - Remote Input: Receive: max. 64 words
 - Remote Output: Send: max. 64 words

2-4-2. Serial communication

- Baud rate : 300, 600, 1200, 2400, 4800, 9600, 19200 , 38400 bps
- Data bits : 7bits, 8bits

[Note] Master-K series: 8bits data

- Stop bits : 1, 2 bits

[Note] Master-K series: 1bit

- Parity bits : None, Odd, Even Parity

[Note] Master-K series: None parity

- Interface : RS232C, RS422

- Self station number : 0~31 station

[Note] Master-K series: Can select up to 0~15 station

- Check sum : Yes or No

[Note] Micrex series (Fuji) : No

2-5. Installation

⊘ Please avoid location to be installed listed below.

- Locations where the temperature changes drastically and condensation occurs.
- Locations where the main unit is exposed to direct sunlight, vibration or impact.
- Locations where strong electrical or magnetic fields are generated.

Earth

- The FG and LG port of the PMU main unit should always be grounded using the Class 3 Ground.
Failing to ground these ports sufficiently could cause electrical shock and malfunctioning.
- The cable for earth should be more than 2 mm².
- The earth point is closer to the PMU main unit and the cable is shorter if possible.

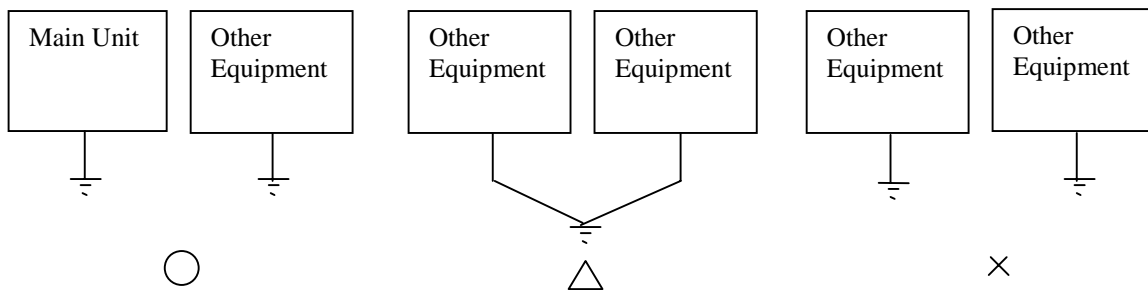

[Drawing. Class 3]

3. The structure of the main menu in PMU main unit

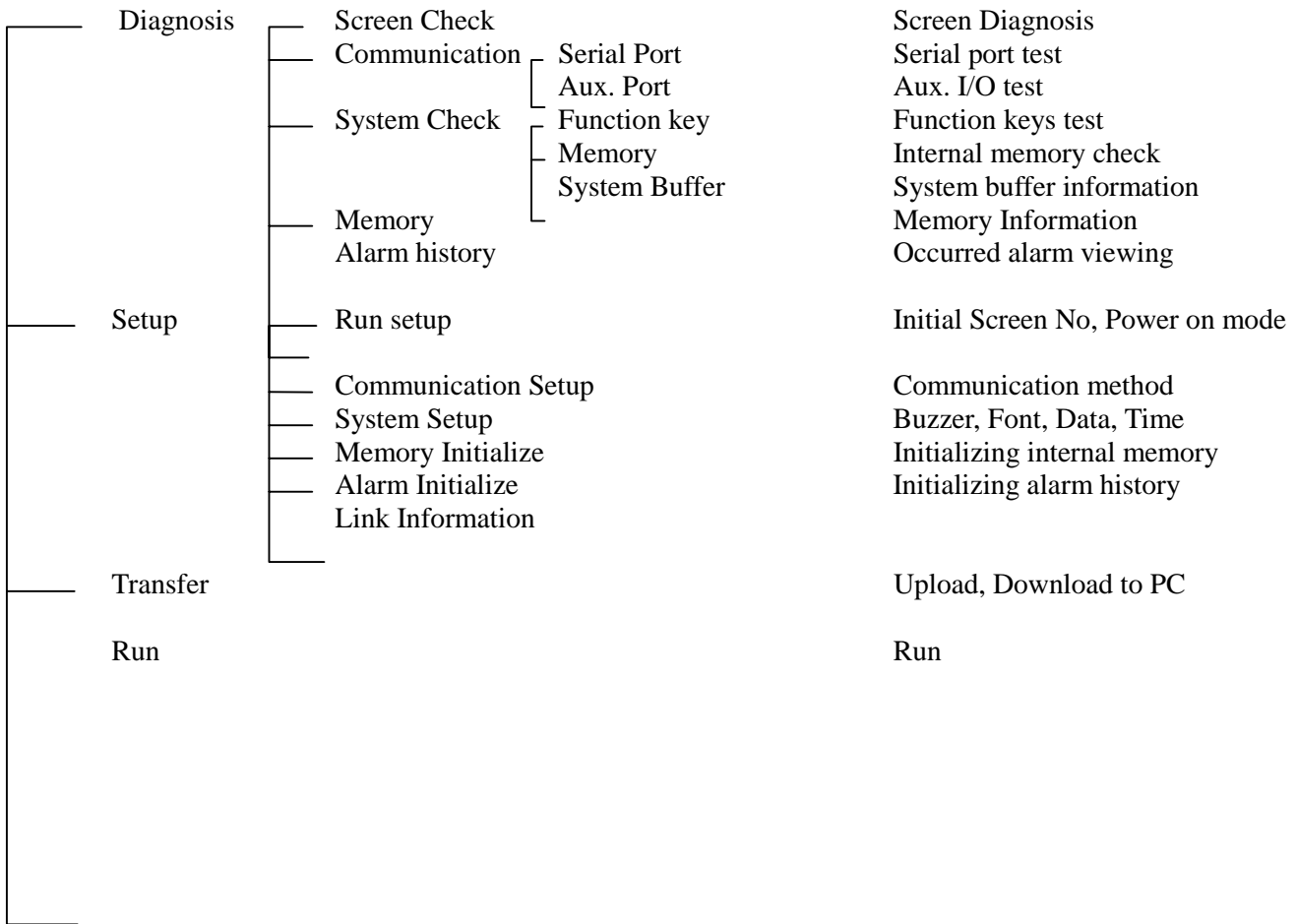

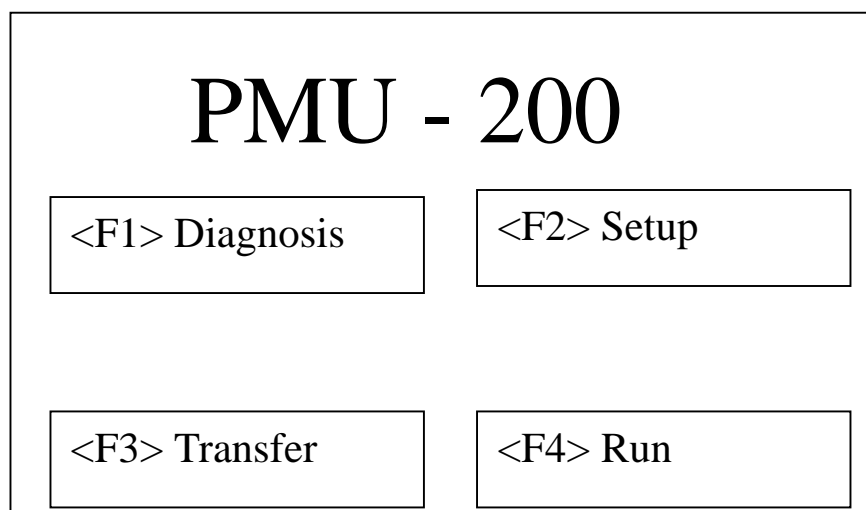

[Drawing. Main Menu]

3-1. Diagnosis

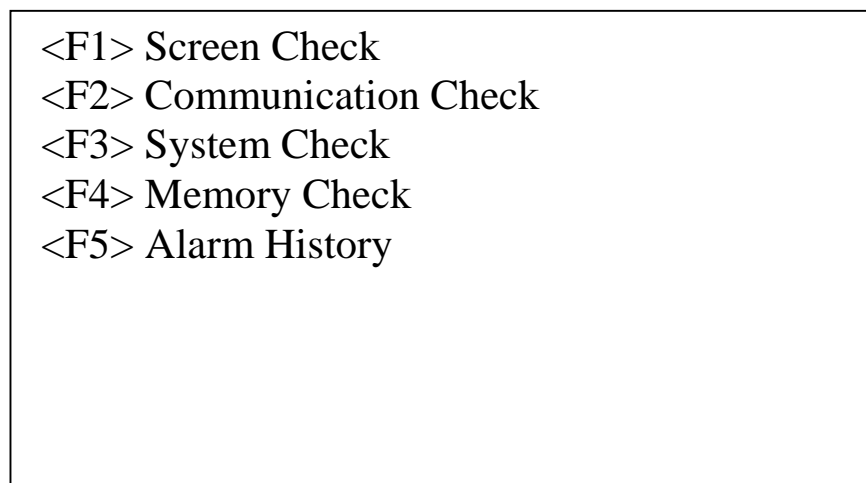

[Drawing. Diagnosis]

3-1-1. Screen Check

This mode is to check the condition of display device and check font, color and line type. Press MENU function key to cancel this menu. Press ENTER key to change next check:

- Display device check
Check the defect of LCD display
- Display Characters

Check the types of characters, size and attributes of characters.

- Tags
Example tags as graph, message, numeric tag

3-1-2. Communication check



<F1> Serial Port Check
<F2> Aux Port Check

[Drawing. Communication Check]

1) Serial port check (Loop back test) [F1]

When push the F1 function key ,it shows the condition of RS232C port. It displays the transmitted characters into ASCII Code. User can test serial port by connecting RXD-TXD and RTS-CTS port(Pin2 to Pin3 and Pin7 to Pin8).

(Test method)

- 1) Pushes F1 Function key
- 2) Connects RXD(No.2) to TXD(No.3) and RTS(Pin 7) to CTS(Pin8) of 9-pin connector and press the Enter key.
- 3) It displays ASCII code in the screen if it's okay.
- 4) If there is a problem it shows the message "RS-232C Port error".
If then, confirm the port after push the ENTER function key.

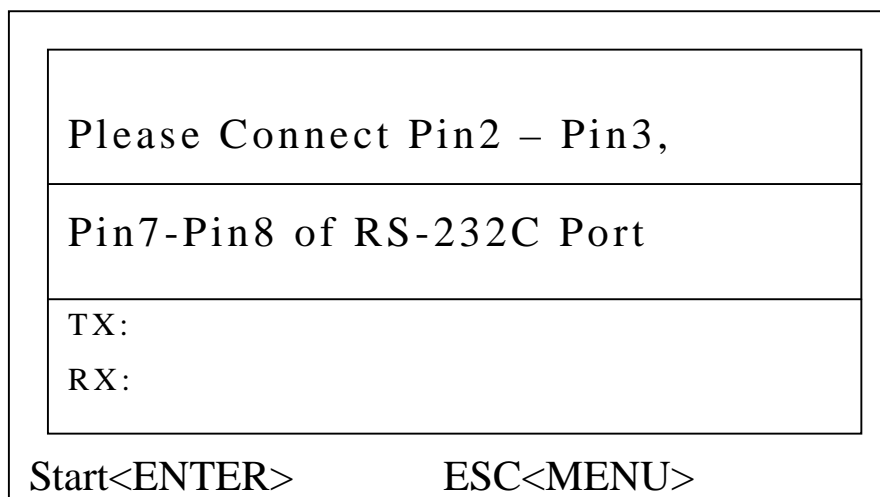

[Drawing. Serial Check]

2) Aux Ports Check[F2]

This mode shows the ON/OFF condition of a input port and output ports in the auxiliary port.
(Test method)

1) Enter the F2 Key or select the Aux Port Check

2) 3 rectangles displayed in the screen of the main unit show the condition of the external input and outputs.

First rectangle shows the state of input port of auxiliary. Second and Third rectangle show the state of output port. If you push F1 or F2 function key, the rectangle will turn on and output port will be switched on.

If you push the function key again, the rectangle will turn off and output port will be switched off

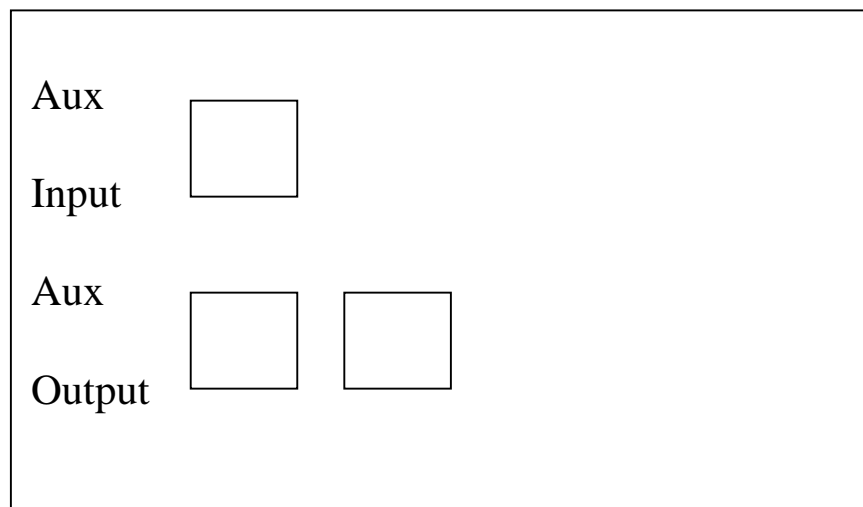

[Drawing. Input Ports]

3-1-3. System check

System check mode shows the information about function key, memory, system buffer internal memory and memory card.

1) Function Key[F1]

This mode diagnoses the operating condition of function keys. It displays ON/OFF condition of 16 keys(F0 ~ F9, MENU, ENTER, SHIFT, ←,↑,→,↓).

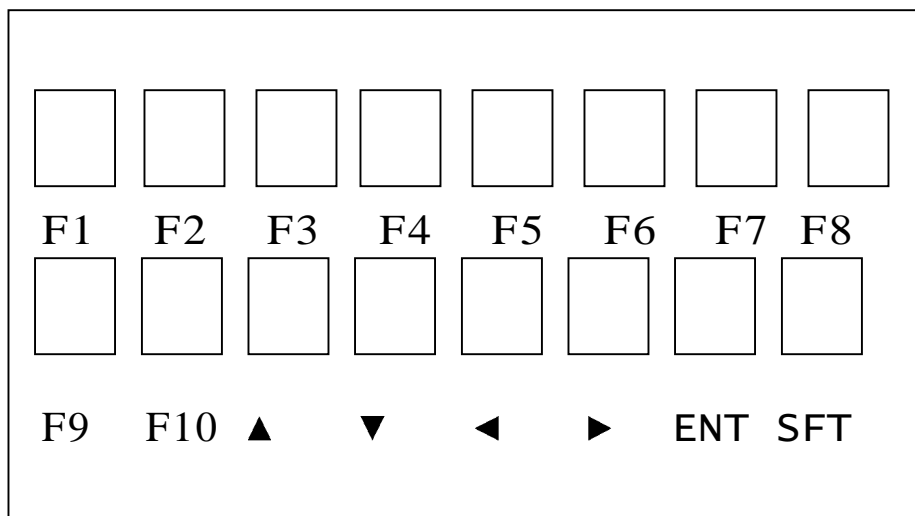

[drawing. Input Ports]

(Operating Method)

1. Select F1 function key.
2. 16 areas displayed onto the screen are matched with function keys of the main unit when push the function keys, they display their own colors.
3. Press MENU key to escape from the test mode.

2) Memory(Internal memory) [F2]

It shows currently used internal memory's contents such as page number, used capacity, unused capacity and contents.

(Operating method)

1. Select F2 function key.
2. Press MENU key to escape from the test mode.

Memory Capacity	:	128 KB
Page 0 Used Memory	:	43 KB
Page 1 Used Memory	:	0 KB
Not Used Memory	:	85 KB

3) System Buffer [F3]

It shows the contents of system buffer memory such as system buffer no., saved value of the buffer.

0:	0	7:	0	14:	47
1:	0	8:	9	15:	1
2:	0	9:	19	16:	1
3:	0	10:	1	17:	0
4:	0	11:	22	18:	7
5:	0	12:	4	19:	1
6:	0	13:	42	20:	3
Prev<UP> Next<Down> ESC<MENU>					

[Drawing. System Buffer]

(Operating Method)

- 1) Press F3 function key.
- 2) For next page move,
 - Press “▲” or “Page Up” of the keyboard
 - Press “▼” or “Page Down” of the keyboard
- 3) When a user make the internal system memory into initial mode,
 - Select MENU function key

3-1-4. Memory Check

It shows the information of internal memory.

They are classified into main screen, symbol file and sub screen. The screen displays screen numbers and descriptions for each screen.

1	First Screen	MAIN
2	MAIN MENU	MAIN
3	AUTO MODE	MAIN
4	AUTO 1	MAIN
2	LAMP	SUB
Prev<UP> Next<DOWN> ESC<MENU>		

[Drawing. Memory Information]

(Operating method)

1. Press F4 function key then displays the information.
2. For a screen move,
 - Press “ ▲ ” or “Page Up” of the keyboard
 - Press “ ▼ ” or “Page Down” of the keyboard

3-1-5. Alarm History

This mode shows the alarm occurred time, messages and can print the alarm history directly.

10/11	13:12:34
RUN ERROR!!!	
10/11	13:50:32
PUMP STOP!	
Prev<UP> Next<DOWN> ESC<MENU>	

[Drawing. Alarm History]

(Operating method)

- 1) Press F5 function key.
- 2) For a screen move,
 - Press “ ▲ ” or “Page Up” of the keyboard
 - Press “ ▼ ” or “Page Down” of the keyboard
- 3) When a user make the saved alarm history into initial mode,
 - Select “Main menu/ Initial setup/ Initialize alarm data”

3-2. Setup

This mode set operation setup, time/date, system setup and memory initialization.

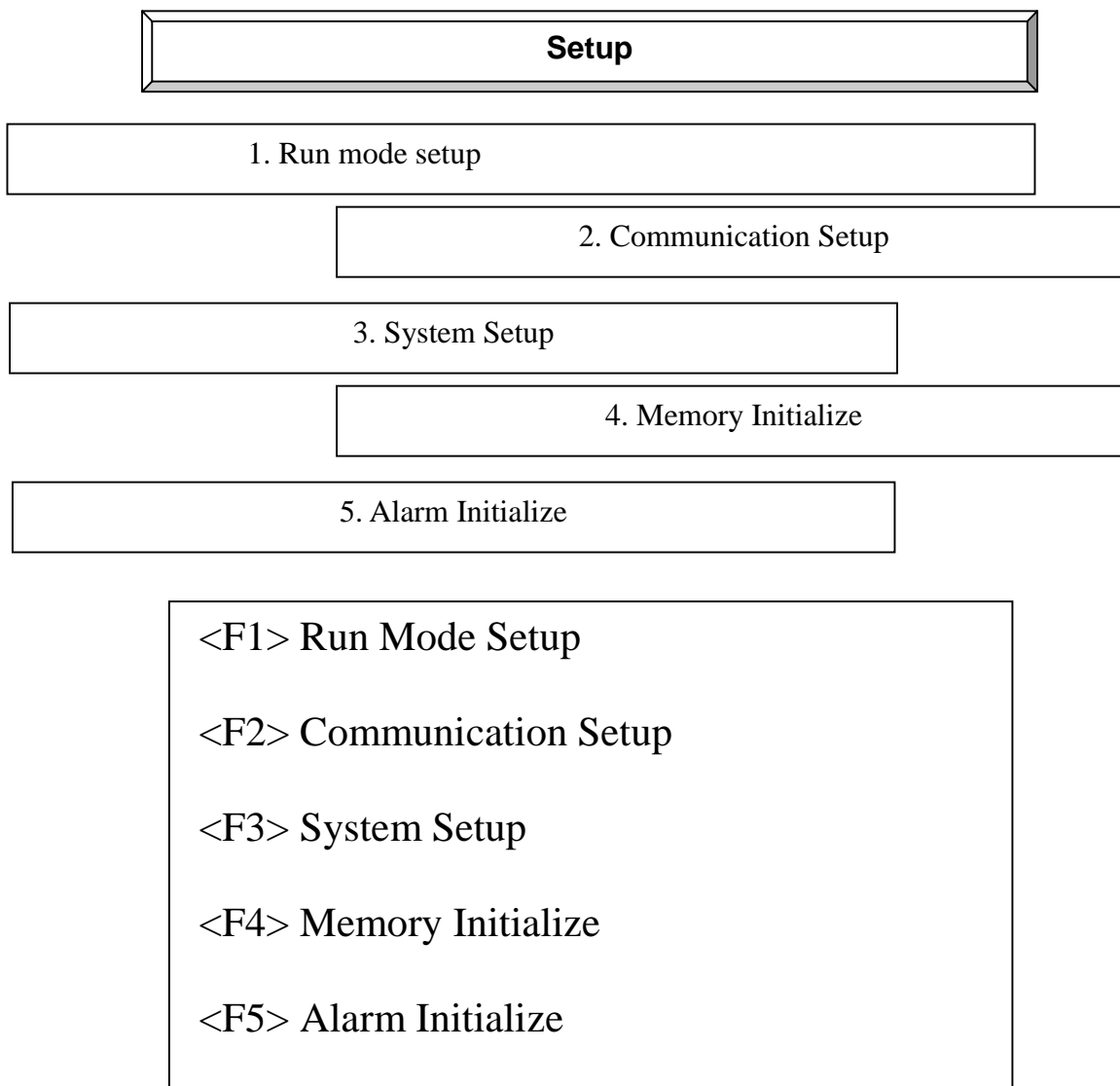

[Drawing. Initial Mode Setup]

3-2-1. Run mode setup

This mode set operation method, initial screen number, initial mode and used memory in operation.

Screen Number	:	[1]
Initial Mode:		
Menu		Run
Latch area	:	[0] – [0]
Save<ENTER>		Cancel<MENU>

(Operating method)

- 1) Press F1 function key when setup menu.
- 2) To select the menu (Screen Number, Initial Mode, etc.)
 - Press “▲,▼” key
- 3) ‘Screen Number (1-999)’ means the first screen to show up in the operation mode.
 - A. Using numeric function key, enter the screen number for initial screen.
- 4) Initial mode

When the power of main unit gets on, a user can select direct operation or main menu.
To select the menu, use F0 to F9 keys

5) Latch area select(0-1023)

Latch area can save all data even if the power gets off.

Note) Please remember that Super capacitor of SRAM can save the data 7 days only.

3-2-2. Communication Setup

This mode sets baud rate, parity bit, data bit, stop bit, RS232C/422 and Station number.

```

Method : Serial/Master-K1000
Baud Rate : [19200]
Data Bit : 7 Bit 8Bit
Stop Bit : 1 Bit 2Bit
Parity Bit : None Even Odd
Station No : [ 0] Signal : RS232 RS422

```

Save<ENTER>

Cancel<MENU>

(Operating method)

- 1) Press F2 function key in the initial setup mode.
To select the left menu
- press direction function key(▲,▼) to be edited
- 2) Method is the communication method that is selected in Link Editor program of PMU-MASTER. This item cannot be changed in the main unit.
- 2) Setup baud rate of serial communication (300, 600, 1200, 2400, 4800, 9600, 19200, 38400).
To select the baud rate, use function keys (◀, ▶)
Whenever user presses the keys, the baud rate will be changed.
- 3) Data bit (7, 8 bits) /Stop bit(1bit, 2 bits)
To select the data bit, use function keys (◀, ▶) .
Whenever user presses the keys, the data bit and stop bit will be changed into 7bit/8bit or 1bit/2bit.
- 4) Parity bits(None, Even, Odd parity)
To select the Parity bits, use function keys (◀, ▶)
Whenever user presses the keys, the parity bit will be changed into none, even or odd parity.
- 5) Interface (RS232C/RS422)
To select the interface, use function keys(◀, ▶) .
Whenever user presses the keys, the interface will be changed into RS232C or RS422.
- 6) station number (0-31) setup
User can use the numeric function key to enter the station number.
- 7) Signal Level (RS232C/RS422)
To select the interface, use use function keys (◀, ▶)
Whenever user presses the keys, the interface will be changed into RS232C or RS422.
This selection is useless when user select communication method as Datalink.

- 8) After entering all data, press 'Enter' function key.
To cancel the selected menu, press MENU function key.

3-2-3. System Setup

This mode sets buzzer beep, font, date, backlight off time and screen type of a main unit.

(Operating method)

- 1) Select System setup in the initial setup mode or press F3 function key.
- 2) To select the left menu
Press direction keys of the function key(▲,▼)
- 3) Buzzer beep(for function key)
To select the type, use function keys (◀,▶)
- 4) Font
To select the type, use function keys (◀,▶)
User have to select "English font". Otherwise, the main unit will show Korean font.
- 5) Date
Use function keys (numeric function keys) to setup current date.
Year, month and day item can be selected using "◀,▶" function key
- 6) Time
Use function keys (numeric function keys) to adjust current Time.
hour, minute and second item can be selected using "◀,▶" function key
- 7) back light off time
Use the numeric function keys in the main unit.(1 minute unit)
- 8) Current time
It only displays the current time of main unit.
- 9) Press ENTER function key to save the data.
- 10) To cancel the setup data, press MENU function key

Buzzer	:	<input type="checkbox"/> Yes	<input type="checkbox"/> No
Font	:	<input type="checkbox"/> English	<input type="checkbox"/> Others
Data	:	[1997]YY[1]MM[23]DD	
Time	:	[17] HH[32] MM[12]SS	
Backlight	off	:	[30]MIN
Current		17:	20 : 34
Screen	:	<input type="checkbox"/> Normal	<input type="checkbox"/> Reverse
		<input type="checkbox"/>	
Save	<ENTER>		Cancel<MENU>

[Drawing. System Setup]

3-2-4. Memory Initialization

This menu is used for initialization of internal memory.

Initialize Memory	
YES<ENTER> NO<MENU>	

[Drawing. Initialization of file memory]

(Operating method)

- 1) Press F4 function key to select Memory Initialization mode in the initial mode setup
- 2) Initialization of internal memory
To initialize the memory, press ENTER function key
- 3) To cancel this menu, press the MENU function key

3-2-5. Alarm Initialization

This menu is used for initialization of internal memory, memory card and the data of initial screen.

(Operating method)

- 1) Press F3 function key to select Alarm initialize mode in the initial mode setup.
- 2) Initialization of internal memory
To initialize the memory, press ENTER function key
- 3) To cancel this menu, press the MENU function key

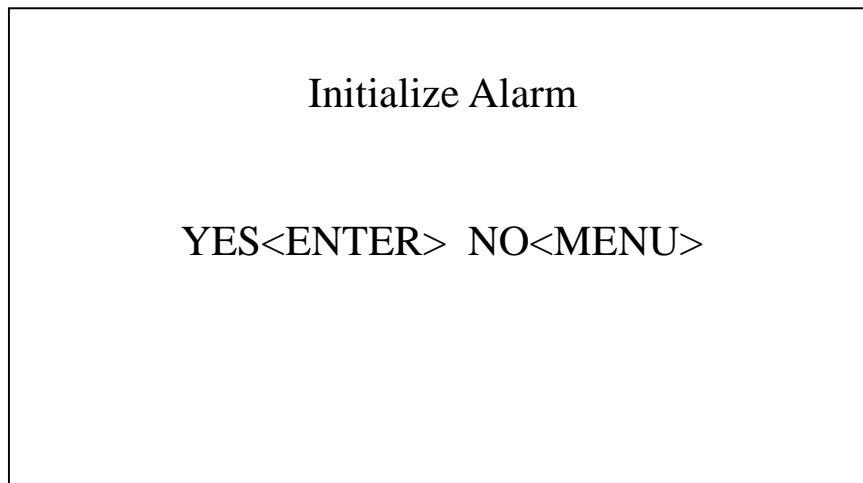

3-3. Transfer

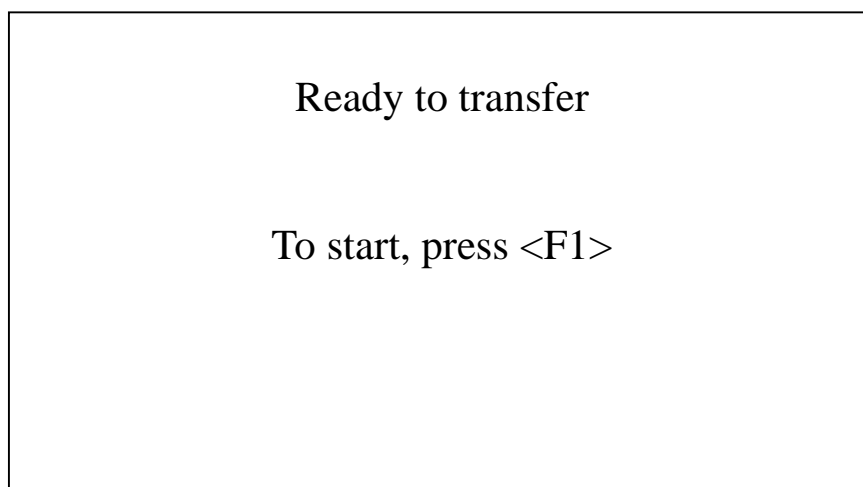

[Drawing. Transfer]

Transfer a project file created in PMU Master S/W to the Main unit.

A user can not only download files from PMU Master S/W to the main unit but also upload to the PC.

This files for transfer should be *. prj files(project files).

(Operating method)

- 1) Press F3 function key in the main menu.
- 2) If you want to cancel this menu, press MENU function key.
- 3) Press F1 function key to make the main unit standby to transfer.
- 4) Transfer the files to the main unit using the project manager of the PMU Master S/W.
(Please refer to the Software manual for PC Operation)
You can see the message " Transfer..."
- 5) After completion, The data is saved to the internal memory with the message 'memory write'.
- 6) 'Completed! ' message is shown to the main unit after execution.
- 7) To interrupt transfer, press MENU function key.

3-4. Run

Sending and receiving between main unit and PLC use system buffer address of PMU.

Data of system buffer indicate graphics or texts displayed in the main screen.

PLC can only write data to system buffer area or read data from system buffer area.

Confirm the following items before operation.

- 1) Designate initial setup and communication setup correctly in the main unit.
- 2) Confirm the connection between PLC and main unit.
- 3) Confirm the screen data , which created in PMU Master s/w, in simulation mode before transfer the data to main unit.

[Appendix]

A.SYSTEM BUFFER

A-1. Definition

System buffer is memory area saving screen control data or error information necessary to operation mode. It consists of 1024 system buffer memories. All data for communication will be saved into system buffer area.

A-2. System buffer Map

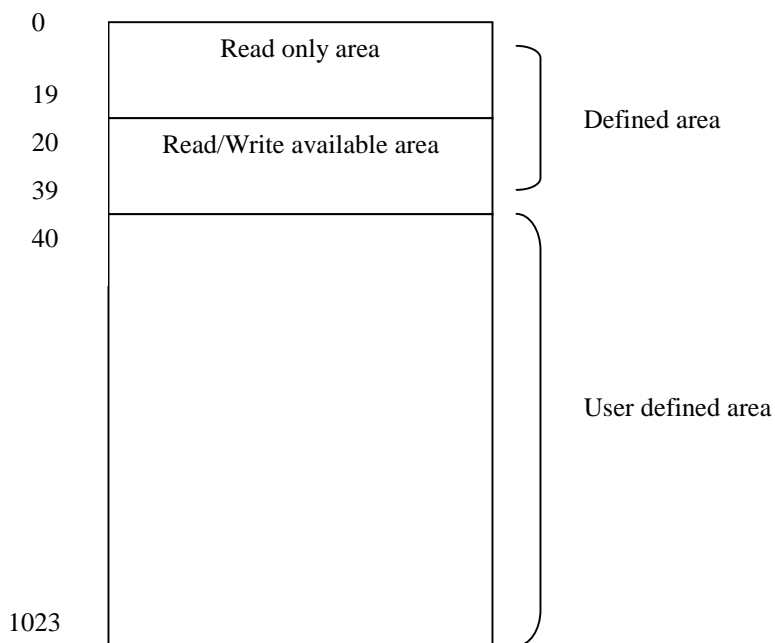

A-3. Description of System buffer

- Read-only System defined buffer

Buffer address		Bit	Contents	
0	System error	0	System ROM Error	
		1	System RAM Error	
		2	Flash Memory Error	
		3	Ask Flash Memory Initialization	
		4	Character ROM Error	
		5		
		6	Clock Error	
		7		
		8		
		9	Function Key Error	
		10-15	Not Used	
1	Serial comm. error	0	Frame error	
		1	Parity error	
		2	Overrun error	
		3	Time out error	
		4	Protocol error	
		5	Check sum error	
		6-15	Not used	
2-6	Fnet error information	0-15		
7	Not used	0-15	Reserved area	
9	Year	0-15	Clock	Year (BCD 16bits : 2 digits)
10	Month	0-15		Month (BCD 16bits : 2 digits)
11	Date	0-15		Date (BCD 16bits : 2 digits)
12	Hour	0-15		Hour (BCD 16bits : 2 digits)
13	Minute	0-15		Minute (BCD 16bits : 2 digits)
14	Second	0-15		Second (BCD 16bits : 2 digits)
15	Fixed value	0-15	When power is on, it always keeps 0 value.	
16	Fixed value	0	When power is on or changes screen, 0→ 1 No.0 bit will be always on.	
17		0-15	Reserved area	
18	System clock	0-15	1 second clock	
19	Aux. Input buffer	0-2	Data from auxiliary port (8bits)	

-
- Read/Write System defined buffer

20	Main screen number	0-15	This buffer can save main screen number to be displayed. If a user wants to change screen into another, enter the screen number to be changed to this buffer.
21	Key display	0-15	Data for Key display tag (lower word)
22	Key display	0-15	Data for Key display tag (upper word)
23	TenKey Enter information	0	When press [enter] key of tenkey, 0 bit will be 1.
24-25		0-15	Reserved area
26		0-15	Reserved area
27	Exit	0-15	If data of this buffer is not '0', Operation will be end.
30	Buzzer output time	0-15	Buzzer output time of auxiliary port
31	Aux. Output information	0-7	Output data (8 bit)of auxiliary port
32	Screen Off setup	0-15	If data of this buffer is not '0', Backlight will be Off.

- User defined buffer

Read/Write available in this buffer area: 40 ~ 1023 buffers

B. Application examples

B-1. PLC Communication specification

B-1-1. PLC Types and communication method

1:1 communication

Serial interface (RS232C, RS422), Datalink, User defined protocol

Method	Comm. mode	PLC Type	PLC CPU type	Comm. Interface module
	Serial Interface	Master-K Series	Master K500/1000 CPU	
		GLOFA-GM	GOL-CPU	
		GLOFA-K		
		Mitsubishi(A2N, A3N)		AJ71UC24
		Mitsubishi(A1S)		
		OMRON	C200H	
		Samsung FARA		
		Fuji PLCs		FFU120B, FFK120A
		LG Inverter		
		AB PLCs(DF1 protocol)		
		Modicon(Modbus)		
	Data Link	Master-K200H		DLU module
		FAM 3.1, 4.0, 5.0		
User defined	-			

B-1-2. Setup items

B-1-2-1. Serial setup items (1:1 Comm.)

Baud rate	300, 600, 1200, 2400, 4800, 9600, 19200,38400
Data Bit	7 bit, 8 bit [Note] Master-K : 8 bit
Stop Bit	1 bit, 2 bit [Note] Master-K : 1 bit
Parity Bit	No parity, Odd parity, Even parity [Note] Master-K : No parity
Interface	RS232C, RS422
Station no.	0-31 Stations
Check sum	Always Yes (Except for Micrex)

B-1-2-2. Data Link setup items

Setting of Station Number	0 to 125 stations
Setting of High Speed Data	Setting buffer numbers for each of input/output data

[Note] No. of Input and output data for setup are max. 64. But, limited up to 32 words when user uses both of input and outputs simultaneously.

[Note] Buffer number should be between 0 to 1023.

B-3. Connection to PLCs

B-3-1-2. Master-, 30S, 60S, 100S, K10S1,

B-3-1-2-1. PMU main unit Setup

Operation mode setup

Operation mode setup

- Select [Initial Menu] → [Operation Setup]
 [Initial screen number]: 0-999 select
 [Power On initial mode]: Initial menu or Operation
 [Memory type]: Internal memory or Memory card

Serial mode setup

Baud rate	300 bps, 600 bps, 1200 bps, 2400bps, 4800bps, 9600bps, 19200bps , 38400bps
Data bit	8 Bits
Stop bit	1 Bit
Parity bit	None
Serial Interface	RS232C (Loader port)
Station Number	None

Link Editor (PC→ PMU Main unit)

- Select Master-K S/H series
- In link table, setup PLC Device, Buffer, Word and Station number
- Please refer to Master-K S/H type address allocation table
- Please refer to Link editor for the detail information.

B-3-1-2-2. PLC Setup

Hardware Dip switch select (Master-K S/H Series)

Master-K S Series can do communicate with PMU main unit through RS232C interface using loader port.
 Baud rate will be fixed with 9600 bps

B-3-1-2-3.PLC Address allocation table(Master-KS/H Series)

Memory area	Address		
	K10S,K30S,K60S,K100S	K10S1	K60H, K200H
Auxiliary Relay (M)	M0000-M0031	M0000-M0015	M0000-M0063
I/O Relay (P)	P0000-P0005	P0000-P0001	P0000-P0255
Keep Relay (K)	K0000-K0015	K0000-K0007	K0000-K0511
Link Relay (L)	L0000-L0015	L0000-L0007	L0000-L0255
Special Relay (F)	F0000-F0015	F0000-F0015	F0000-F0255
Timer- current value (T)	T0000-T0127	T0000-T0047	T0000-T0255
Counter-current value (C)	C0000-C0127	C0000-C0015	C0000-C0255
Data Register (D)	D0000-D0255	D0000-D0063	D0000-D1023

B-3-1-2-4. Cable connection (PMU↔ PLC)

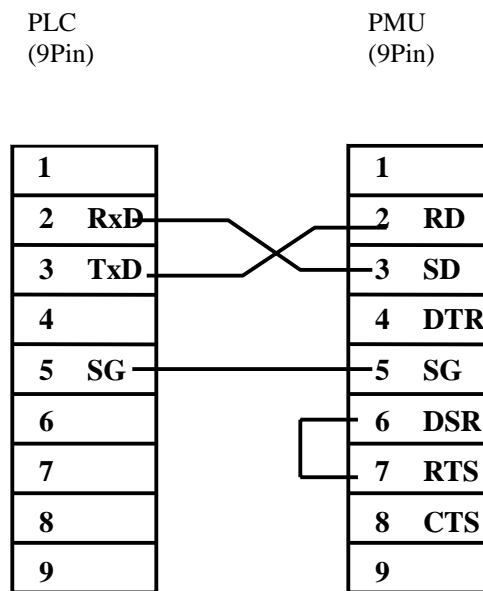

B-3-1-3. GLOFA-GM Cnet Setup

B-3-1-3-1. PMU main unit setup

Operation mode setup

- Select [Initial Menu] → [Operation Setup]
 [Initial screen number]: 0-999 select
 [Power On initial mode]: Initial menu or Operation
 [Memory type]: Internal memory or Memory card

Serial mode setup

Baud rate	300 bps, 600 bps, 1200 bps, 2400bps, 4800bps, 9600bps, 19200bps , 38400bps
Data bit	8 Bits
Stop bit	1 Bit
Parity bit	None
Serial Interface	RS232C (Cnet module)
Station Number	None

Link Editor (PC→ PMU Main unit)

- Select GLOFA-GM (Cnet) series
- In link table, setup PLC Device, Buffer
- Please refer to GLOFA-GM(Cnet) address allocation table.
- Please refer to Link editor for the detail information

B-3-1-3-2. PLC Setup

Hardware Rotary switch select (GLOFA-GM Cnet)

Mode	Description
1	RS232C Mode
3	RS232C / RS422 Mode
4	RS422 Mode
5	RS232C Mode
7	RS422 Mode

* Station number setup: Use Frame editor software*

* PMU Communication: Select 3 mode(RS232C/RS422 mode)

B-3-1-3-3. PLC Address allocation table (GLOFA-GM)

Type	Word	Address Map
GM1	%IX	%IW0.0.0 ~ %IW63.7.3
	%QX	%QW0.0.0 ~ %QW63.7.3
	%M	%MB0 ~ %MB65535
GM2	%IX	%IW0.0.0 ~ %IW31.7.3
	%QX	%QW0.0.0 ~ %QW31.7.3
	%M	%MB0 ~ %MB65535
GM3	%IX	%IW0.0.0 ~ %IW7.7.3
	%QX	%QW0.0.0 ~ %QW7.7.3
	%M	%MB0 ~ %MB32767
GM4	%IX	%IW0.0.0 ~ %IW7.7.3
	%QX	%QW0.0.0 ~ %QW7.7.3
	%M	%MB0 ~ %MB16383
GM5	%IX	%IW0.0.0 ~ %IW1.9.3
	%QX	%QW0.0.0 ~ %QW1.9.3
	%M	%MB0 ~ %MB8191

Example: %MW0000

%Q(I)W0.Q.0

Base, Slot, Card [Please refer to GLOFA-GM Manual]

B-3-1-3-4. Cable connection (PMU ↔ PLC)

RS-232C connection (9 Pin port)

Pin No.	Description	Signal	Direction
1	Carrier Detect	CD	
2	Sending Data	SD(TXD)	—————>
3	Receiving Data	RD(RXD)	<—————
4	Data Terminal Ready	DTR	—————>
5	Signal Ground	SG	
6	Data Set Ready	DSR	<—————
7	Request Sending	RS(RTS)	—————>
8	Confirm Sending	CS(CTS)	<—————
9		RI	

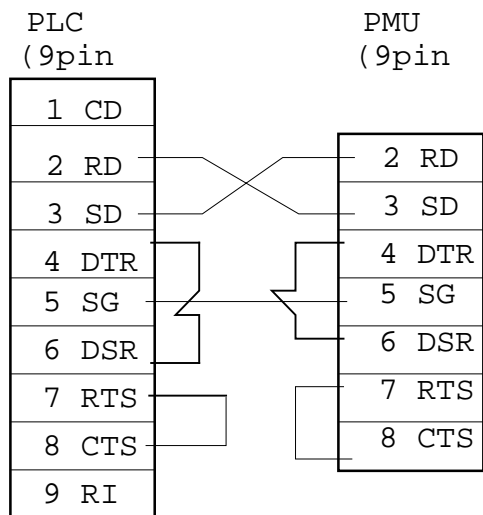

RS-422 connection (6 Pin Port)

Pin No	Description	Signal	Direction
1	Receiving Data A	RDA	←
2	Receiving Data B	RDB	←
3	Sending Data A	SDA	→
4	Sending Data B	SDB	→
5	Signal Ground	SG	
6	Frame Ground	FG	

