

1. Overview

1.1 Introduction

1-1-1. Definition

This User's manual describes the specifications, handling, utility functions and other information of PMU-300 Programmable Monitoring Unit.

PMU-300 is the operating panel with touch screen to replace originally used operation panel such as switch operations and displays of data, lamps and messages. It makes user realize CIM (Computer Integrated Manufacture) easily using FA monitoring equipment like PMU series.

1-1-2. Features

- 1) Windows based software package for screen editing
(Windows 3.1, Windows 95)
 - Project Manager
 - Screen Editors: Main and Sub Screen Editor
 - Symbol Editor, Alarm Editor, Message Editor and Link Editor
- 2) Simulation to debug screen editing without connecting PLC and/or PMU main unit
The graphic software supports simulation function how the screen is operating well.
So user can debug the screen simply without any connection between PLC or PMU main unit.
- 3) Various Interfaces for other PLCs
 - Serial interface(RS232C/RS422)
 - LG PLCs-(GLOFA-GM Series, GLOFA-K Series, Master-K S Series)
 - Fuji PLCs-(MICREX series)
 - Mitsubishi PLCs-(MELSEC series)
 - OMRON PLCs (SYSMAC series)
 - Matsushita PLCs(FARA series)
 - AB PLCs (PLC-5/SLC-500 series with DF1 protocol)
 - LG Inverters
 - Modicon PLCs (QUANTUM series with Modbus protocol)

*1 windows is a registered trademark of Microsoft Corporation.

- High speed communications
Data Link : Master-K series, FAM(Factory Automation Manager)
- User defined Protocol communication

- 4) Display components
LCD-MONO , EL-MONO

- 5) Abundant Diagnosis
 - Touch keys check
 - Font check,
 - Memory card check
 - Check of OS(Operating System) area of internal memory
 - Alarm history check
 - CPU communication check

- 6) Easy interface for user
Matrix Touch Panel (16 x 12 keys)
User defined Function keys (F1 ~ F10 / 0 ~ 9 , ESC , FUN , T/F , ENT , UP , DOWN)

1-2. Hardware Structure

1-2-1. Partial Names and Functions

A	Display	Components : MONO-EL, B/W LCD, Blue LCD Touch screen : 320 x 240 dot
B	Function Keys	F0 ~ F9 : User defined function keys, ESC, FUN, T/F, ENT, (,) : Total 16 keys
C	Power LED	Power ON mode
D	T/F LED	ON: Ten-Key Mode OFF: Function Key Mode
E	Run LED	Run Mode
F	Power Supply Terminal	DC24V(+24V, GND, NONE)
G	Switch	Power ON switch
H	Auxiliary I/O ports	8 Outputs, 3 Special function outputs, 3 Inputs
I	RS232C port	Serial port(9pin port)
J	RS422 port	SD+,SD-,RD+,RD-SG,FG
K	DLU port	Data Link Communication port for MK series

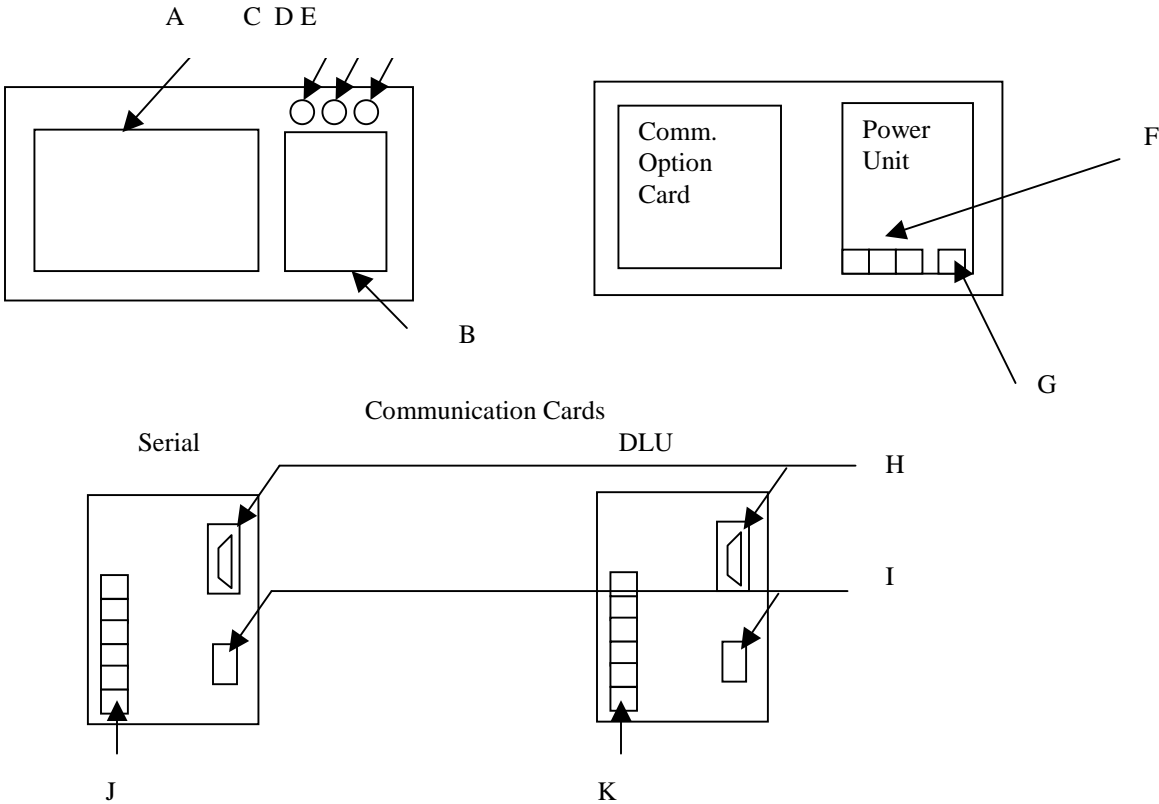

Special Function Keys(16 Keys)

ESC	To cancel a mode in the execution of menu, To go back to the previous mode or step
FUN	In Run Mode, F1: Call previous screen F2: Call original screen F3: S/W Reset F4: Exit Run mode F5: Alarm list
T/F	Can select Ten-key mode or Function Key mode by toggle switch in the Main Unit
ENT	In edit mode : to enter data or execute some mode In Ten-Key Mode : to enter key data In Function Mode : For Function keys
↑	In edit mode : Up key In Run mode : For Function Keys
↓	In edit mode : Down key In Run mode : For Function Keys
0 ~9	In Run mode, In Ten-Key Mode : Key values In Function Key Mode : Function keys

1-2-2. System Configuration

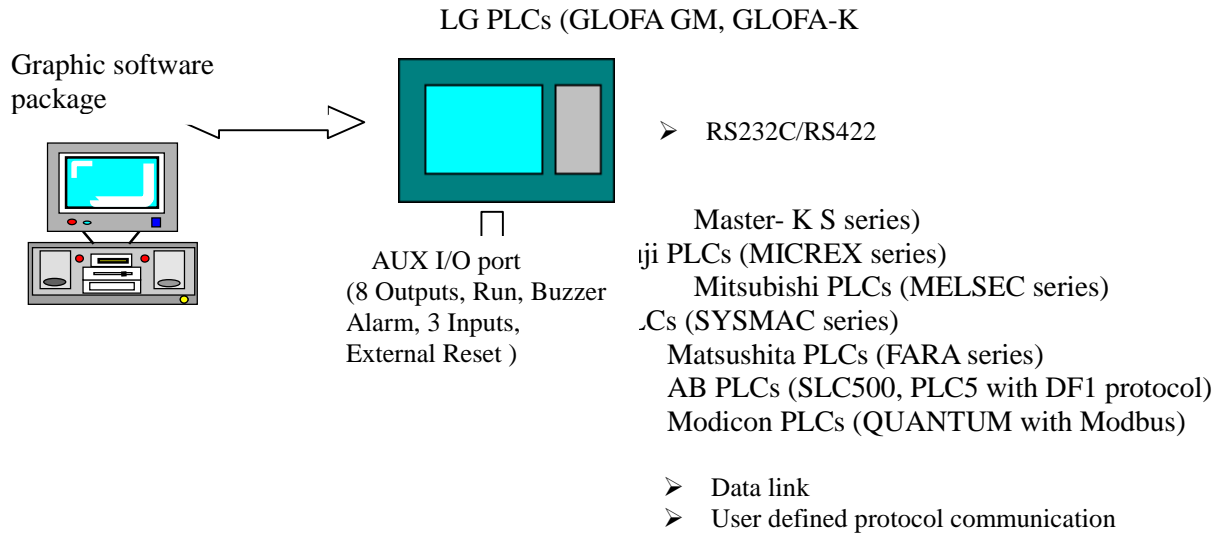

1-3. Procedures to prepare for starting operation

Procedure for editing screen in PC based software and PMU main unit.

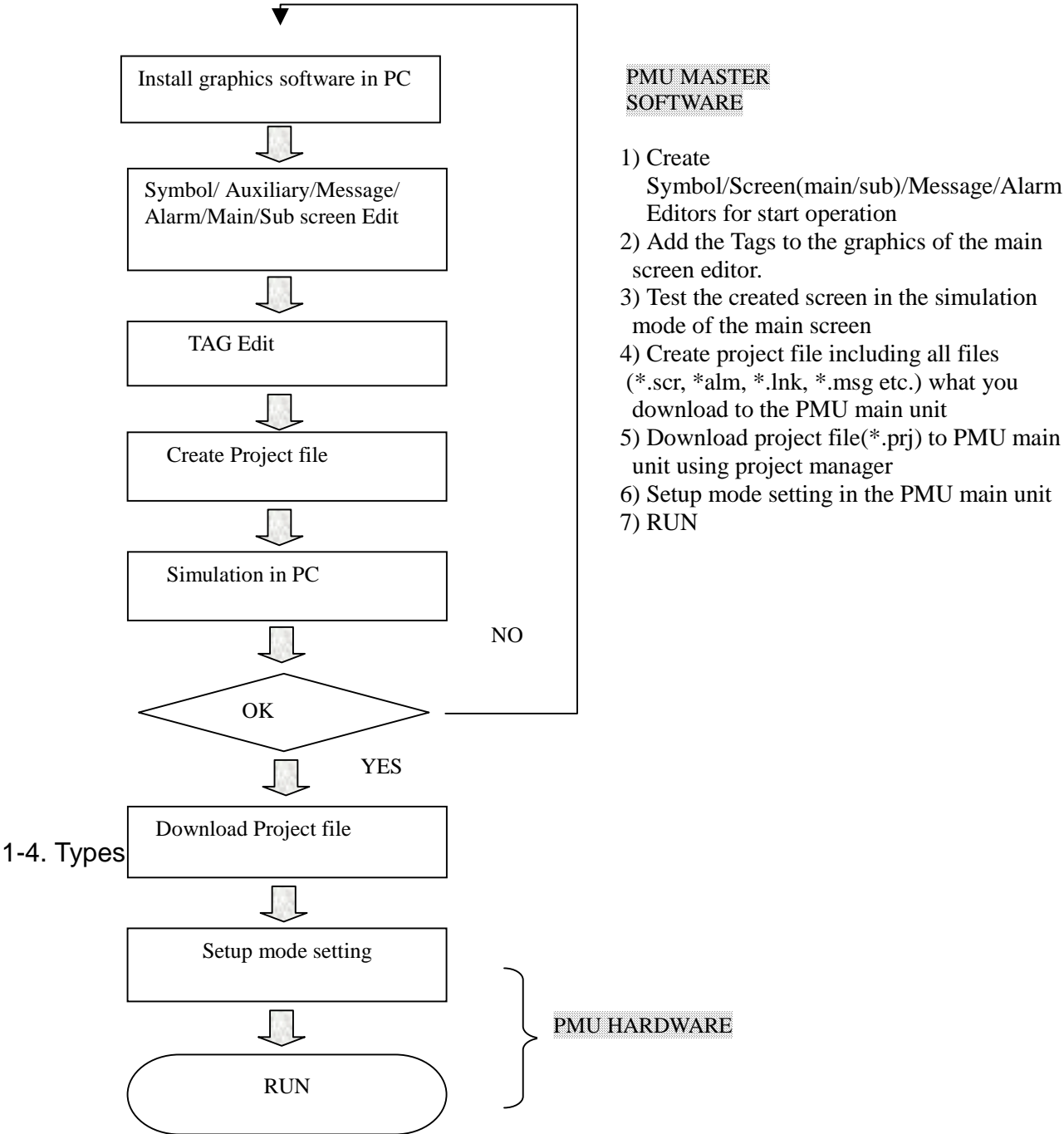

Functions	Contents
N Tag (Numeric Tag)	This function displays data stored in word devices of PLC
A Tag (Auxiliary Tag)	This function displays graphics or messages from the already created sub-screen onto the main screen.
S Tag (Symbol Tag)	This function displays the already created symbols from symbol Editor onto the main screen.
T Tag (Touch Tag)	This function writes specified value to a word device or turns on a specified bit device when a touch key is touched.
K Tag(Key Tag)	This function is used for entering numeric data like ten-key and user Create a touch key such as a number value key on the sub-screen. (available screen file numbers : 900 ~ 999)
V Tag(Key indicator Tag)	This function makes the numeric values by a key tag displayed onto the screen. It also should be saved as after sub-screen number 900(ex:900.sub)
G Tag(Graph Tag)	This function displays the data stored in multiple word devices as a bar or closed line.
H Tag(Window Tag)	This function switches to a specified window screen when a touch tag is enabled.
F Tag(Function key Tag)	This function can use 12 function keys of PMU main unit. This function writes specified value to a word device or turns on a specified bit device when a function key is touched. User defines them.
W Tag(Buffer write Tag)	This function writes specified data or bit to a designated system buffer.
D Tag(Delay Tag)	According to the operating condition, it writes specified value or turns on A specified bit device after the designated timer is On.
B Tag(Block Tag)	This function enables not to be touched by establishing the territory.
M Tag(Message Tag)	This function enables designated message from the message editor to be displayed as bit or word devices are turned on or off.
I Tag(Precision Adjust Tag)	This function enables data of designated system buffer to be precisely adjusted or send output data to auxiliary port in the PMU main unit.
L Tag(Lamp Tag)	This turns lamps on and off in conjunction with bit devices being turned on and off from PLC. Lamp color can be changed to any of colors.
X Tag(Trend graph Tag)	This function allows the data stored in a word device to be collected at a specified timing and displayed as a trend graph. After the data is displayed to the specified range, the display scrolls.
C Tag(Computation Tag)	This function enables data computed by condition to be entered into the specified buffer.
J Tag(Move Tag)	This function enables a already created symbol in symbol editor to be displayed onto a main screen in accordance with the specified buffer criteria.
R Tag(Area move Tag)	This function enables a symbol to be displayed by the designated position based on the value of a 2-point word device.
P Tag(Pie Tag)	This function shows the data stored in word devices as a pie or meta graph.
Q Tag(String Tag)	This function writes data from PLC as a string of ASCII code.
E Tag(Statistic tag)	This function shows the percentage of the each data(up to 8) as a circle or rectangle in accordance with the changeable system buffers.

2.

2. Specifications

2-1. General specifications

Items	LCD Type	EL Type
Input power(Voltage)	24 V dc (Min. 20 V~ Max. 28V)	
Power consumption	Less than 56VA	
Noise withstand resistance	Impulse noise voltage : 1,500Vp-p □ (50/60Hz 1minute)	
Insulation resistance	500VDC at 10MΩ	
Ambient operating temperature	0~40□	0~55□
Ambient storage temperature	-20~60□	-40~75□
Ambient operating humidity	40□, 85%RH	40□, 93%RH
Ambient storage humidity	40□, 85%RH	55□, 95%RH
Environment	No corrosive gases	
Vibration endurance	10 to 25 Hz(X,Y,Z direction 2G 30 minutes)	

2-2. Performance specifications

Items	Specifications
Display component	Mono-EL, B/W LCD, Blue LCD
Resolution	320 x 240 Dots
Display properties	Normal, Toggle, Blink
Text enlargement	1~8 times(width x height each)
Types of graphics	Line, Polyline, rectangle, Circle, Oval, Painted rectangle, Arc, Pie, Text, Clock
Type of graph	Bar, Trend, Closed line, Statistical, Pie and Meter graph
Screen numbers	999 (main/sub/symbol/alarm/message each)
Touch panel	Pressure matrix method(162x12 touch cells)
Touch key size	20 x 20 dots (minimum)
Auxiliary I/O ports	4 Inputs(3: DI points, 1: Reset point), 8 Outputs(3 : DO points, 1: Alarm output, 1: Buzzer output, 1: Run output)
Communication Interface	RS232C/RS422, Datalink
Printer	Centronix standard compatible
Function keys(Hardware)	ESC, FUN, T/F, F0~F9, UP,DOWN

2-3. Auxiliary I/O Specifications

2-3-1. Input Specification

Items	Specifications	
Input points	4 points(Data 3 points, Reset 1 point)	
Rated input voltage	DC24V(DC19.2 ~ DC30V:-15/20%)	
Input Current	10mA	
Delay time	ON	10mA
	OFF	15mA
Common	Input data common(DC24V+), Switch Input common(DC 24+)	
Insulation method	Photo-coupler insulated	
External connection	Connector type	

2-3-2. Output Specification

Items	Specifications	
Output points	11 points(Data :8 points, Run :1point, Buzzer :1point, Alarm: 1point)	
Rated input voltage	DC24V(DC19.2 ~ DC30V:-15/20%)	
Output Current	10mA	
Delay time	ON	Less than 1msec
	OFF	Less than 1msec
Common	GND	
Insulation method	Photo-coupler insulated	
External connection	Connector type	

2-3-3. Auxiliary I/O pin assignment

Pin No.	Signal	Contents	Pin No.	Signal	Contents
1	Alarm	Alarm output	14	DO(7)	Data output 8 points
2	BUZ	Buzzer output	15	DO(6)	
3	RUN	Run output	16	DO(5)	
4	N.C.	No connection	17	DO(4)	
5	DICOMM	Output common (GND)	18	DO(3)	
6	DICOMM		19	DO(2)	
7	DICOMM		20	DO(1)	
8, 9, 10	N.C.	No connection	21	DO(0)	
11	SWCOMM(24V)	Input common (24V)	22	Reset	Reset point
12	SWCOMM(24V)		23	SI(2)	Data Input 3 points
13	SWCOMM(24V)		24	SI(1)	
			25	SI(0)	

2-4. Communication Specification

2-4-1. Datalink Communication

- Baud rate : 1 M bps
- PLC connection and PMU station number
 - Connectable up to Max. 32 PMUs
 - Station number: 1 ~ 125 stations
- The number of words to be connected per station
 - Remote I/O: Send: max. 32 words, Receive: :max. 32 words
 - Remote Input: Receive: max. 64 words
 - Remote Output: Send: max. 64 words

2-4-2. Serial communication

- Baud rate : 300, 600, 1200, 2400, 4800, 9600, 19200 , 38400 bps
- Data bits : 7bits, 8bits
[Note] Master-K series: 8bits data
- Stop bits : 1, 2 bits
[Note] Master-K series: 1bit
- Parity bits : None, Odd, Even Parity
[Note] Master-K series: None parity
- Interface : RS232C, RS422
- Self station number : 0~31 station
[Note] Master-K series: Can select up to 0~15 station
- Check sum : Yes or No
[Note] Micrex(Fuji) : No

2-5. Installation

⊘ Please avoid location to be installed listed below.

- Locations where the temperature changes drastically and condensation occurs.
- Locations where the main unit is exposed to direct sunlight, vibration or impact.
- Locations where strong electrical or magnetic fields are generated.

Earth

- The FG and LG port of the PMU main unit should always be grounded using the Class 3 Ground.
Failing to ground these ports sufficiently could cause electrical shock and malfunctioning.
- The cable for earth should be more than 2 mm².
- The earth point is closer to the PMU main unit and the cable is shorter if possible.

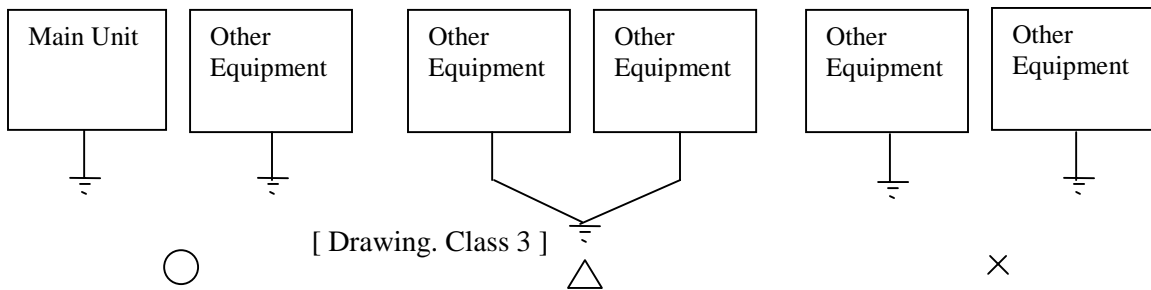

3. Main menu structure in PMU main unit

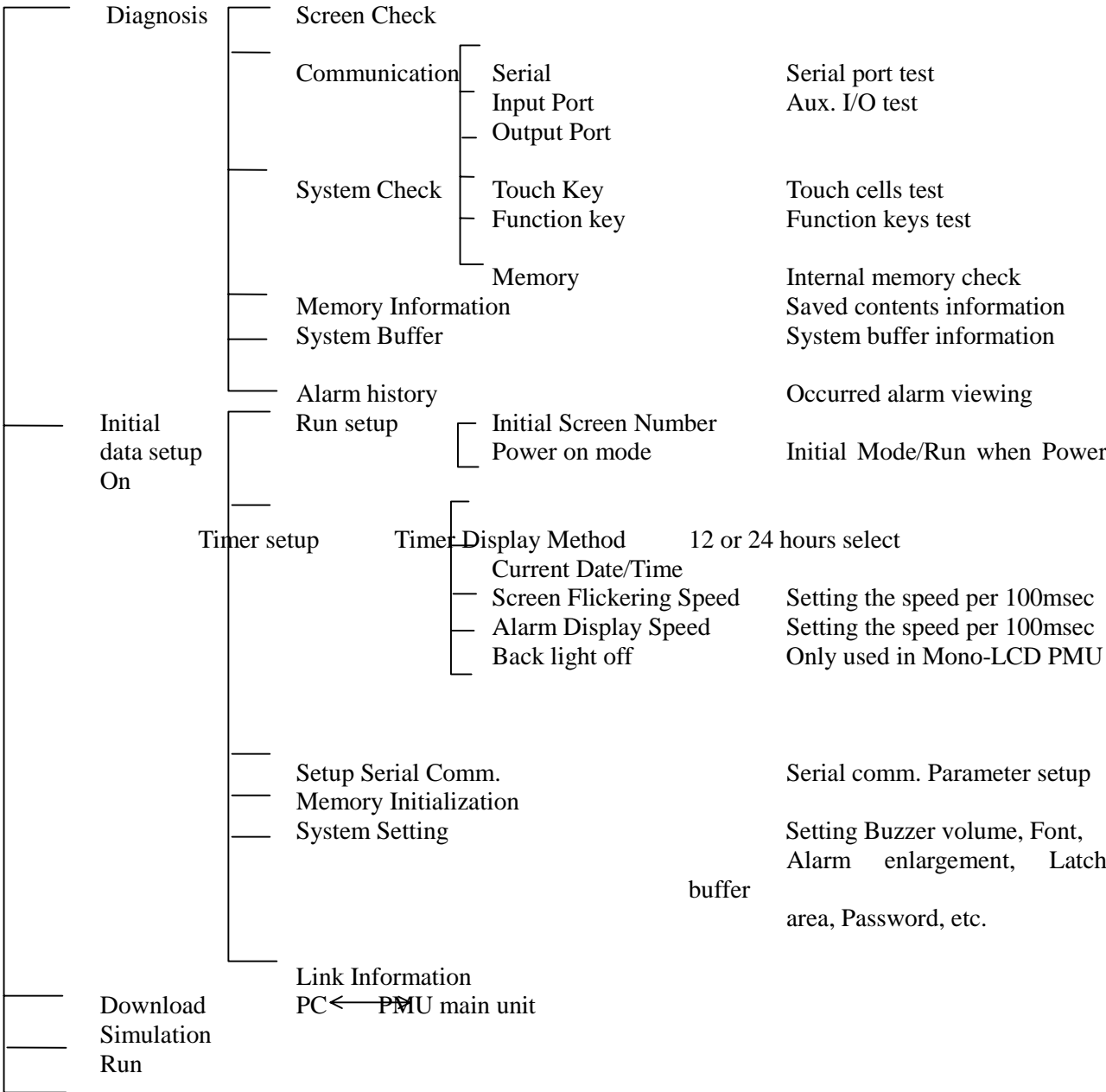

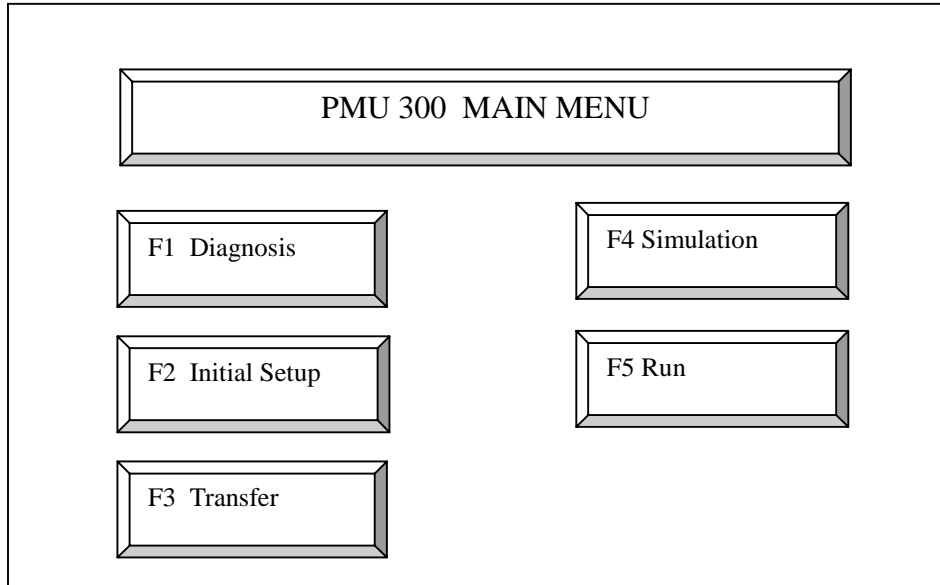

[Drawing. Main Menu]

3-1. Diagnosis

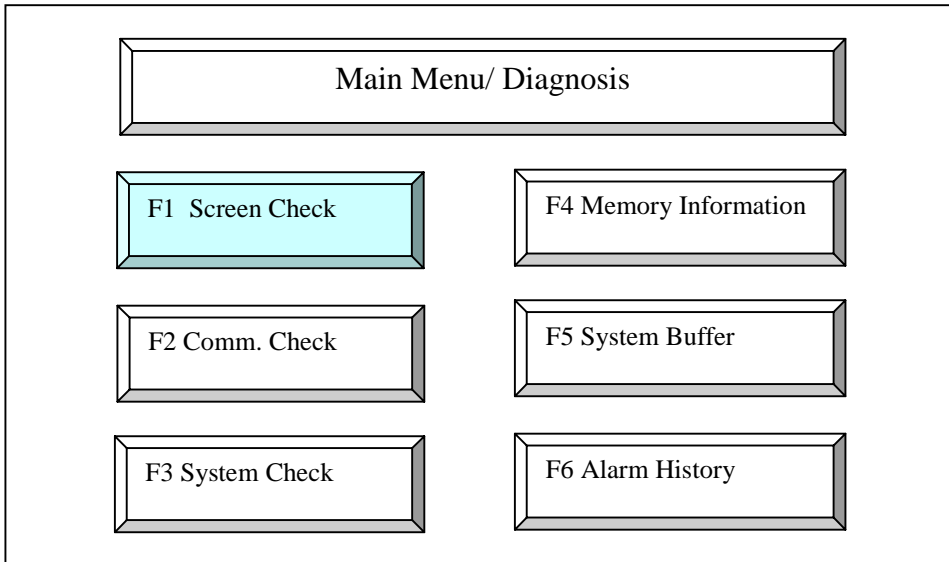

[Drawing. Diagnosis]

3-1-1. Screen Check

This mode is to check the condition of display device and check font, color and line type.

- **Display Characters**
Check the types of characters, size and attributes of characters.
- **Line types and patterns**
Each 8 types of line and pattern are shown in this mode.
- **Graphics display**
Check types of graphics as circles, ovals, arc, rectangles, and painted rectangles
- **Tag types**

- Check types of tags as graph, pie, statistical, move, message, trend, numeric and alarm tag
- **Display device check**
This mode is to check the condition of all touch cells.
Touches the upper left side to escape from the blank screen.

3-1-2. Communication check

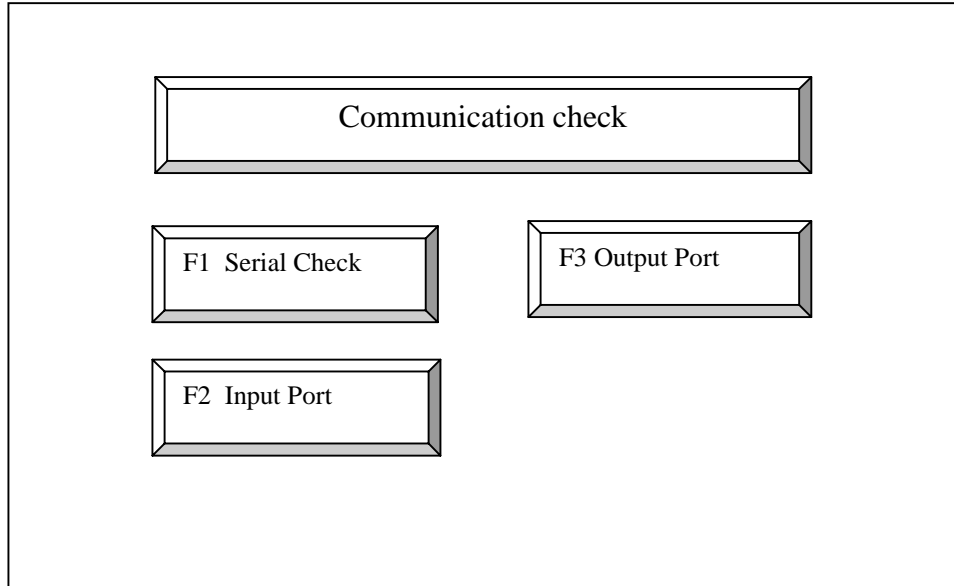

[Drawing. Communication Check]

1) Serial port check (Loop back test) [F1]

When push the F1 function key or touch key, it shows the condition of RS232C port. It displays the transmitted characters into ASCII Code. User can test serial port by connecting only RXD and TXD port.

(Test method)

- 1) Pushes F1 Function key or touches the serial check key
- 2) Connects RXD(No.2) and TXD(No.3) port of 9-pin connector and press the Enter key.
- 3) It displays ASCII code in the screen if it's okay.

- 4) If there is a problem it shows the message “RS-232C Port error”.
If then, confirm the port after push the ESC touch key.

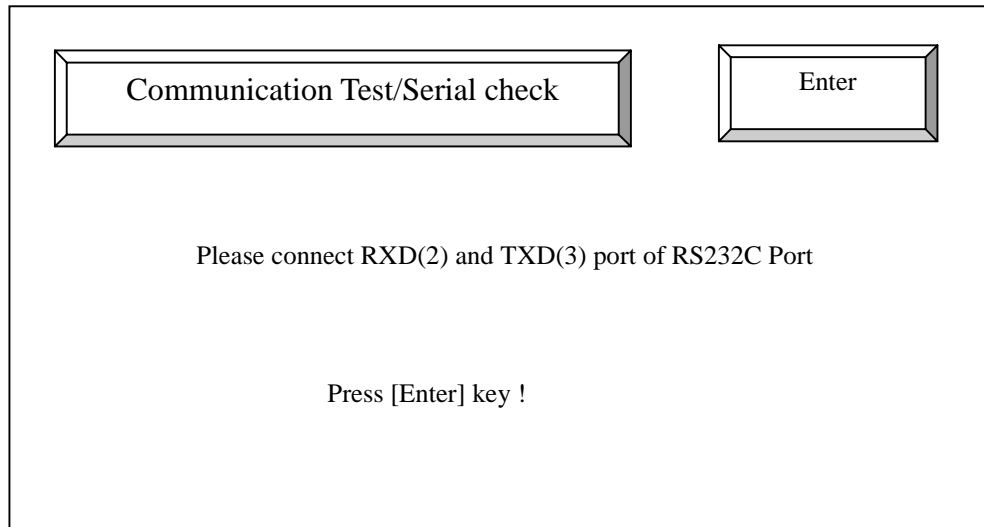

[Drawing. Serial Check]

2) Auxiliary Input Ports[F2]

This mode shows the ON/OFF condition of input ports in the auxiliary port.
(Test method)

- 1) Enter the F2 Key or select the Input port test by touch in the comm. Test mode.
- 2) 4 Circles displayed in the screen of the main unit shows the condition of the external inputs.
If it is operated well it will be turned on if not it will be turned off.

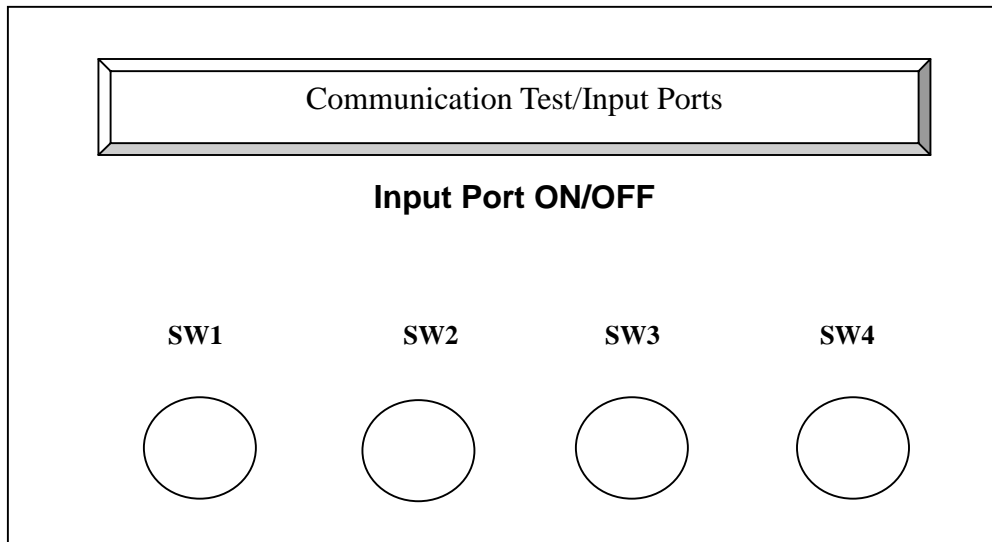

[Drawing. Input Ports]

3) Output Ports[F3]

This mode shows the ON/OFF condition of output ports in the auxiliary port.

(Test method)

- 1) Enter the F3 Key or select the output port test by touch in the comm. Test mode.
- 2) 11 touch keys displayed in the screen of the main unit shows the condition of the external outputs. When a user touches the specified touch key among D1~BUZ, it sends ON signal to the output port of the Auxiliary port.

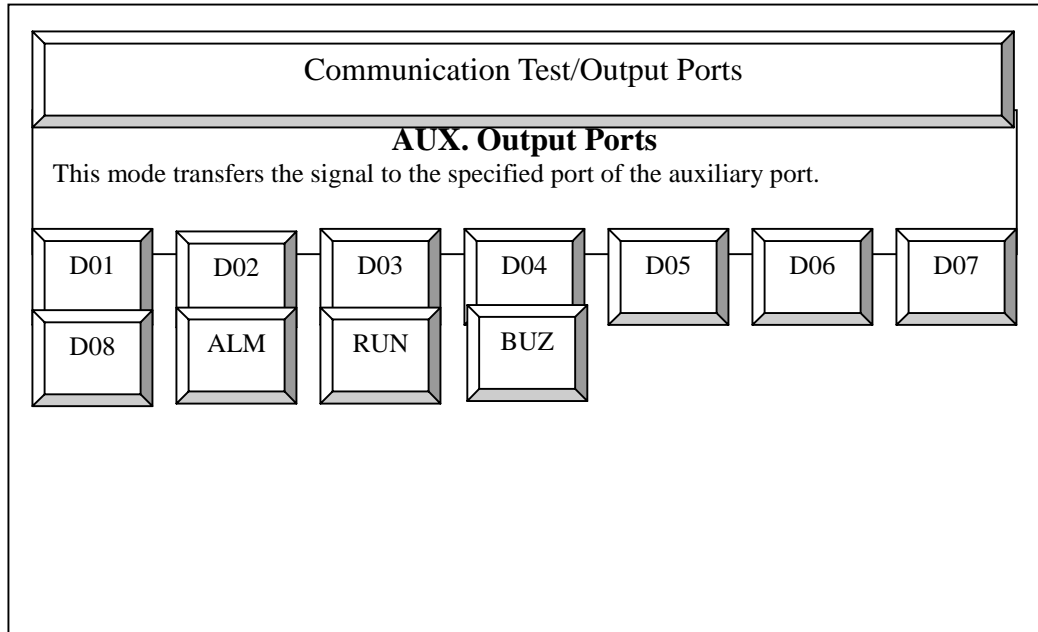

3-1-3. System check

System check mode shows the information about touch key, function key, keyboard input, buzzer, internal memory and memory card.

1) Touch key[F1]

A user can confirm that the each touch cells operate well or not by touching the cells in the screen. The size of each cell is 20 x 20 dots and total cell numbers are 16 x 12(192).

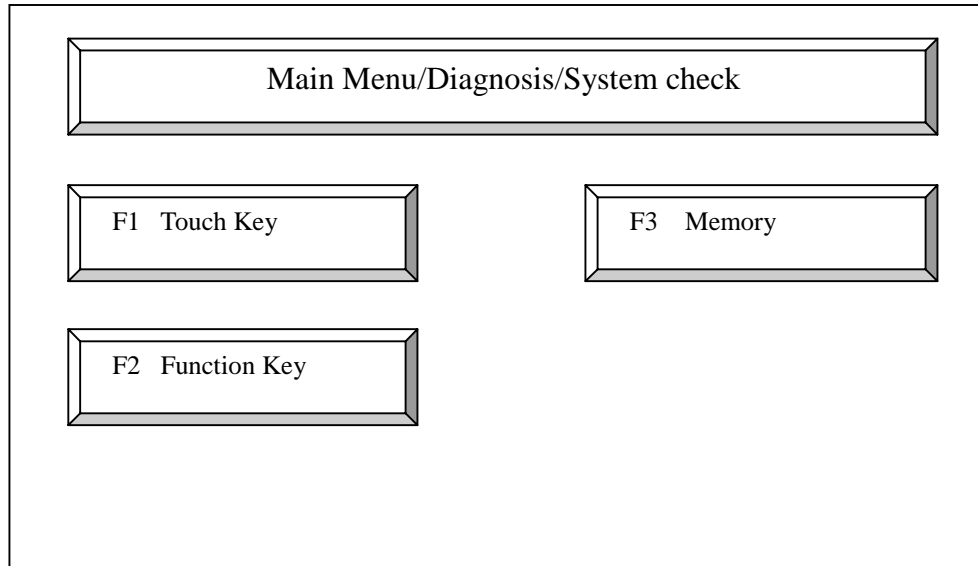

[Drawing. System Check]

(Operating Method)

1. Select Touch key button in the system check mode or press F1 function key.
2. Displays 192(16x12) touch cells and can test the cells by touching cells.
3. Press ESC key to escape from the test mode

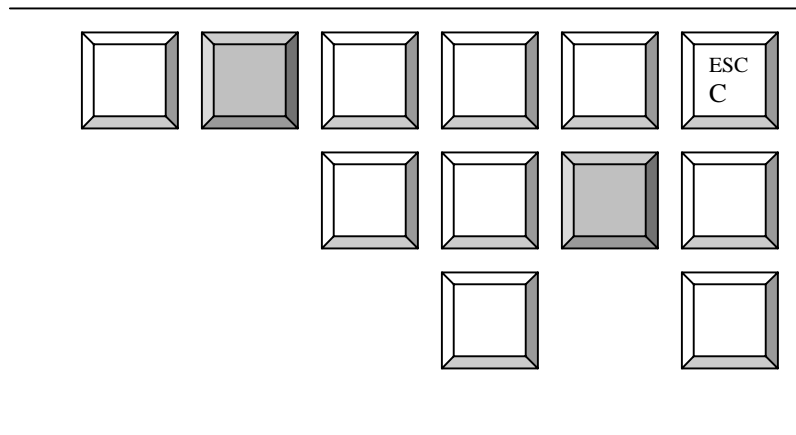

[Drawing. Touch key test screen]

2) Function Key[F2]

This mode diagnoses the operating condition of function keys. It displays ON/OFF condition of 16 keys(F0 ~ F9, ESC, FUN, T/F).

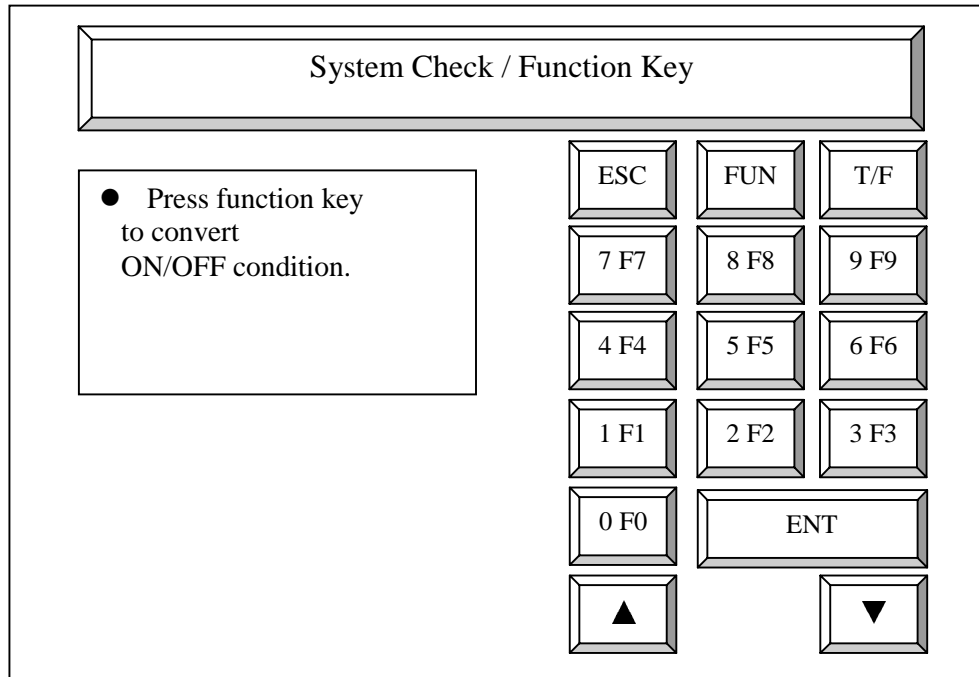

[drawing. Input Ports]

(Operating Method)

1. Select Function key button in the system check mode or press F2 function key.
2. 16 areas displayed onto the screen are matched with function keys in the right side of the main unit when push the function keys, they display their own colors.
3. Press ESC key to escape from the test mode.

3) Memory(Internal memory) [F3]

It shows currently used internal memory's contents such as page number, used capacity, unused capacity and contents.

(Operating method)

1. Select Memory Key in the system check mode or press F5 function key.
2. Press ESC key to escape from the test mode.

System Check / Memory			
Page No.	Used memory	Not used memory	Contents
0	63460	02060	Information
1	00000	65536	File data
2	00000	65536	File data
3	00000	65536	File data
4	00000	65536	File data
5	00000	65536	File data

3-1-4. Memory Information

It shows the information of internal memory or memory card.

They are classified into main screen, symbol file and sub screen. The screen displays screen numbers and descriptions for each screen.

Diagnosis / Memory Information		
No.	Description	Screen type
301	Lamp test	Main screen
302	Current meter	Main screen
303	Voltage meter	Main screen
401	Line 1	Main screen

[Drawing. Memory Information]

(Operating method)

1. Select Memory information in self-test mode or press F4 function key then displays the information.
2. For a screen move,
 - Press “ ▲ ” or “Page Up” of the keyboard
 - Press “ ▼ ” or “Page Down” of the keyboard

3-1-5. System Buffer

It shows the contents of system buffer memory such as system buffer no., saved value and description of the buffer.

Information			
No.	Decimal	Hex	Description
0000	0000	00000	System error information
0001	00000	00000	Communication error info.
0002	65535	FFFF	DLU error information
0003	65535	FFFF	Fnet information

[Drawing. System Buffer]

(Operating Method)

- 1) Select System buffer button of the diagnosis mode or Press F5 function key.
- 2) For next page move,
 - Press “ ▲ ” or “Page Up” of the keyboard
 - Press “ ▼ ” or “Page Down” of the keyboard
- 3) When a user make the internal system memory into initial mode,
 - Select “Main Menu/Initial setup/Initialize internal memory”

3-1-6. Alarm History

This mode shows the alarm occurred time, messages and can print the alarm history directly.

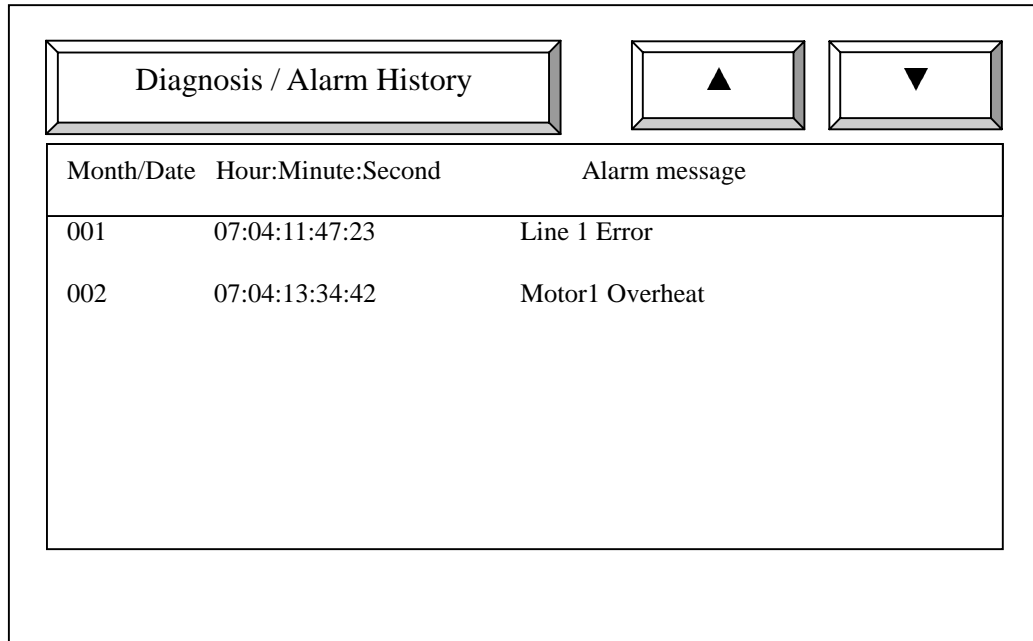

Month/Date	Hour:Minute:Second	Alarm message
001	07:04:11:47:23	Line 1 Error
002	07:04:13:34:42	Motor1 Overheat

[Drawing. Alarm History]

(Operating method)

- 1) Select Alarm history in the self-test mode or press F6 function key.
- 2) For a screen move,
 - Press “ ▲ ” or “Page Up” of the keyboard
 - Press “ ▼ ” or “Page Down” of the keyboard
- 3) When a user make the saved alarm history into initial mode,
 - Select “Main menu/ Initial setup/ Initialize alarm data”

3-2. Initial mode setup

This mode set operation setup, time/date, system setup and memory initialization.

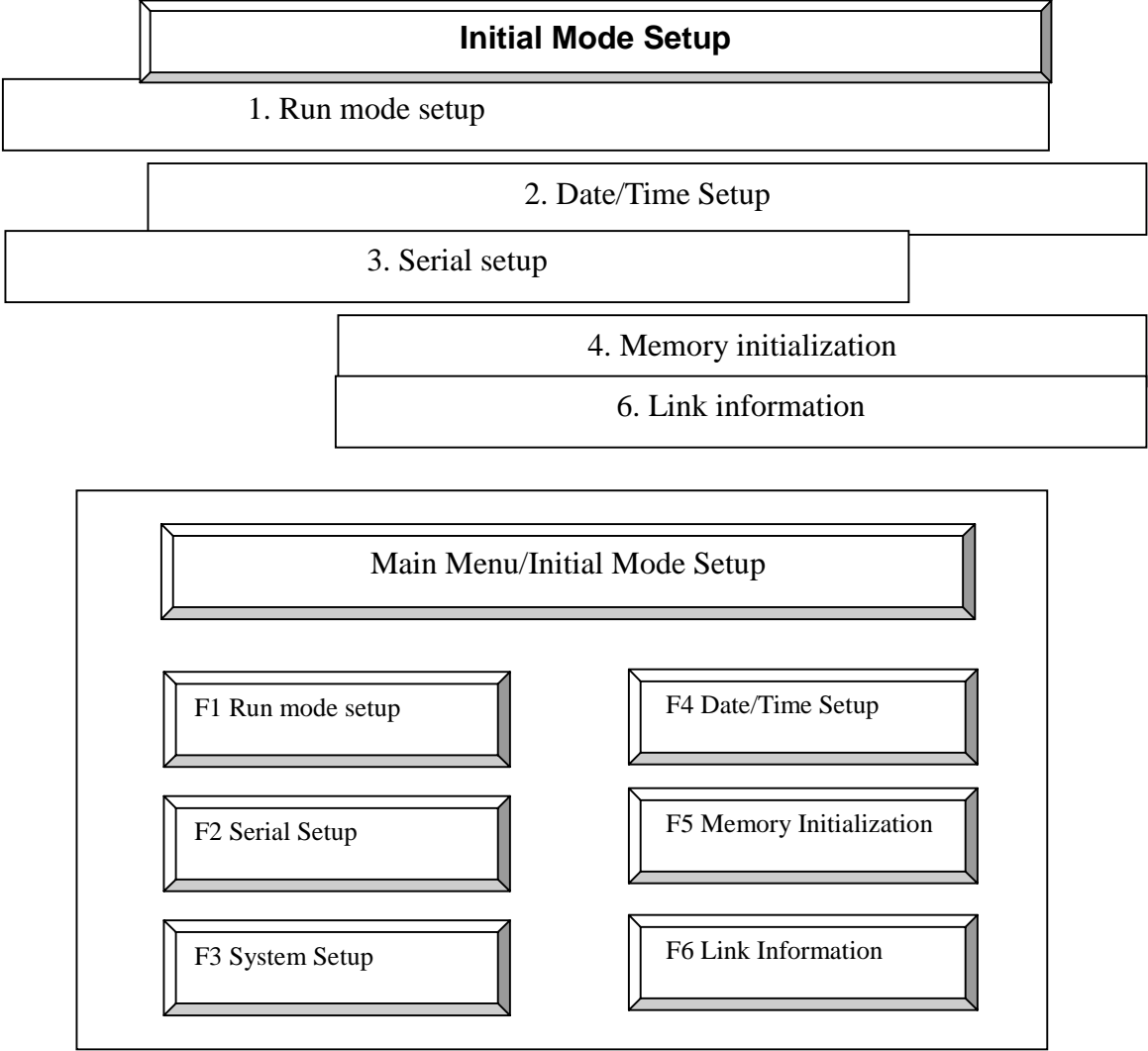

[Drawing. Initial Mode Setup]

3-2-1. Run mode setup

This mode set operation method, initial screen number, initial mode and used memory in operation.

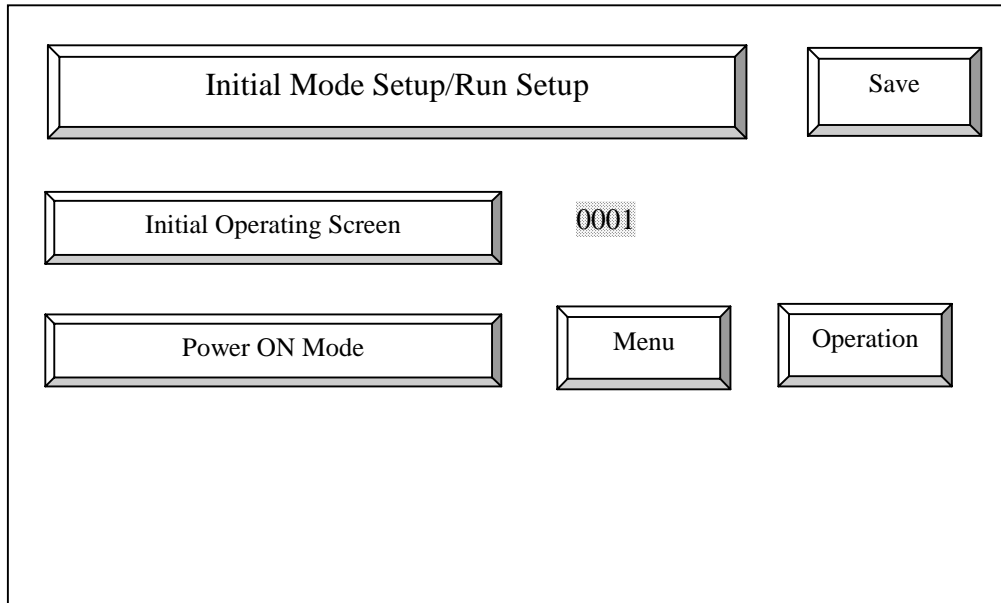

(Operating method)

1) Select Operation setup in the initial mode setup or press F1 function key.

2) To select the left menu (Initial Operating Screen, Power ON Mode, etc.)

- Press “↑” key or press touch key to be edited

Press “↓” key or press touch key to be edited

3) ‘Initial screen number (1-999)’ means the first screen to show up in the operation mode.

A. Enter with Touch key: After touch the tag, enter the screen number for initial screen.

Then presses enter key.

Cancel : Cancel entering data

Delete : Deletes entered all numbers

← : Deletes last entered number

B. Enter with Function Key : Presses enter key after enter the screen number in the right side of the screen.

4) Power ON mode

When the power of main unit gets on, a user can select direct operation or main menu.

To select the menu, use F0 to F9 keys

3-2-2. Date/Time Setup

This mode sets date and time of a main unit.

(Operating method)

- 1) Select Date/Time setup in the initial setup mode or press F4 function key.
- 2) To select the left menu
 - Press direction keys of the function keys.
 - Select the menu directly by touching the menu bar.
- 3) Display method
 - Select '24hours display' or '12 hours display'
- 4) Input method of data
 - Use function keys or ten-key of the main unit to setup current date/time/flickering speed/display speed/ back light off time.
- 5) Current Date/Time setup
 - Use function keys (numeric function keys) in the right side of the screen or ten-key of the main unit to setup current date/time.
- 6) Setup the screen flicker time
 - Use the function keys or ten keys in the main unit.(* 100 msec)
- 7) Speed of Alarm display
 - Use the function keys or ten keys in the main unit.(* 100 msec)
- 8) Setup of back light off time
 - Use the function keys or ten keys in the main unit.(* 100 msec)
- 9) Press Save button to save the data or enter key of the function keys.
- 10) To cancel the setup data, press ESC button of the screen.

Initial Mode Setup / Date/Time Setup		Save
Display Method	24 hours	12 hours
Current Date/Time	0000 - 00 - 00 00 - 00	
Flickering Speed of Screen	000 * 100msec	
Speed of alarm display	000 * 100msec	
Back light OFF time	000 * Minute	

[Drawing. Date/Time Setup]

3-2-3. Serial Setup

This mode sets baud rate, parity bit, data bit, stop bit, RS232C/422 and Station number.

Initial Mode Setup / Serial Setup		Save
Baud rate (300-38400)	[19200]	
Data bit/Stop bit	7/1 7/2 8/1 8/2	
Parity bit	None Even Odd	
Interface	RS-232C RS-422	
Station number (0-31)	01	

(Operating method)

1) Select Serial setup mode in the initial setup mode or press F2 function key.

To select the left menu

- select the menu directly by touching the menu bar
- press direction key to be edited

2) Setup baud rate of serial communication (300, 600, 1200, 2400, 4800, 9600, 19200, 38400).

To select the baud rate, use touch keys or function keys.

Whenever user presses the keys, the baud rate will be changed.

3) Data bit (7, 8 bits) /Stop bit(1bit, 2 bits)

To select the data bit, use touch keys or function keys.

Whenever user presses the keys, the data bit and stop bit will be changed into 7/1, 7/2, 8/1, 8/2.

4) Parity bits(None, Even, Odd parity)

To select the Parity bits, use touch keys or function keys.

Whenever user presses the keys, the parity bit will be changed into none, even or odd parity.

5) Interface (RS232C/RS422)

To select the interface, use touch keys or function keys.

Whenever user presses the keys, the interface will be changed into RS232C or RS422.

6) station number (0-31) setup

Ten key will be enabled when user touches menu mode twice. User can use the ten keys to enter the station number.

- CN(Cancel), BK(Back to..), CL(Clear)

7) After enter all data, press Enter button or press save button on the screen.

To cancel the selected menu, press ESC button.

3-2-4. Memory Initialization

This menu is used for initialization of internal memory, memory card and the data of initial screen.

The diagram illustrates the 'Initial Mode Setup/ Memory Initialization' screen. At the top left is the title 'Initial Mode Setup/ Memory Initialization' and at the top right is an 'Enter' button. Below the title is a 'Password' field containing the value '[0000]'. Underneath the password field is the instruction 'Enter the password and press enter key for execution. !'. At the bottom, there are three menu items: 'F1 Initialization of internal memory', 'F2 Initialization of initial setup', and 'F3 Initialization of alarm data'.

[Drawing. Initialization of file memory]

(Operating method)

- 1) Select Memory Initialization mode in the initial mode setup or press F5 function key.
- 2) Initialization of internal memory
To initialize the memory, press the password button, enter the password, then user can find "Execute after select initialization item". Press F1 key or touch memory initialization area.
The initialization of internal memory will be executed.
- 3) Initialization of initial setup
This menu is to clear the initial setup data including link edit. Same as the above.
- 4) Initialization of alarm data
This menu is to initialize alarm data in the main unit. Same as the above

3-2-5. System Setup

In this mode, User can set Buzzer beep, Screen blink interval, Password and Fonts.

(Operating method)

- 1) Select System setup mode in the initial mode setup or press F3 function key.
- 2) To select the left menu
 - Press “↑, ↓“ keys in the function keys.
 - Can select the menu directly by touching the menu bar.
- 3) Buzzer beep for touch key
To select the type, use touch keys or function keys.
- 4) Display position of alarm message
This menu designates the display position of alarm message. Whenever user presses the keys, the display position will be changed into upper or below position.

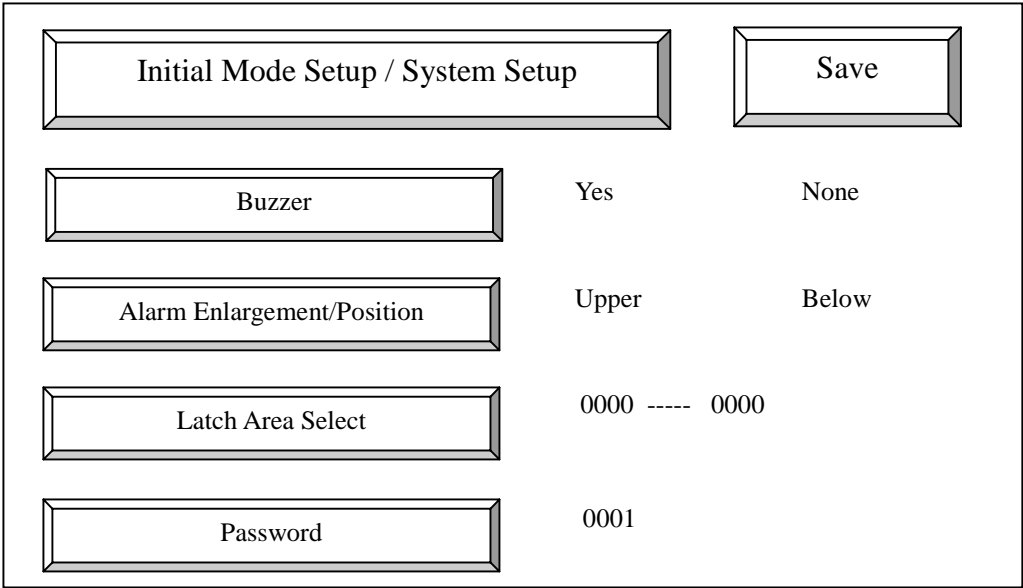

5) Latch area select(0-1023)

Latch area can save all data even if the power gets off.

Note) Please remember that Super capacitor of SRAM can save the data 7 days only.

6) Password – (4 digit)

This menu is useful to check the initialization of internal memory or memory card.

The unit of the backlight off time can be set by minute.

7) After setup all data, press Enter button.

To cancel the selected menu, press ESC button.

3-2-6. Link Setup

1. Communication Method

1:1, User defined protocol

2. Communication mode

1) 1:1 communication

- Serial interface(RS232C/RS422)
 - GLOFA GM series
 - GLOFA K series
 - Master K series : Master-K10S1, K10S, 30S, 60S, 100S,500,1000
 - Micrex PLC(Fuji Electric)
 - Mitsubishi PLCs : AnN, AnA AnU series
 - OMRON PLCs
 - Samsung Electronics(FARA PLCs)
 - LG Inverter
 - AB PLCs(DF1 protocol)
 - Modicon PLCs(Modbus)
- High speed communications
Data Link: Master-K series, FAM(Factory Automation Manager)

2) User defined Protocol communication

3. PLC Type

1:1 -> Selected PLC

User defined protocol -> Not shown

3-3. Transfer

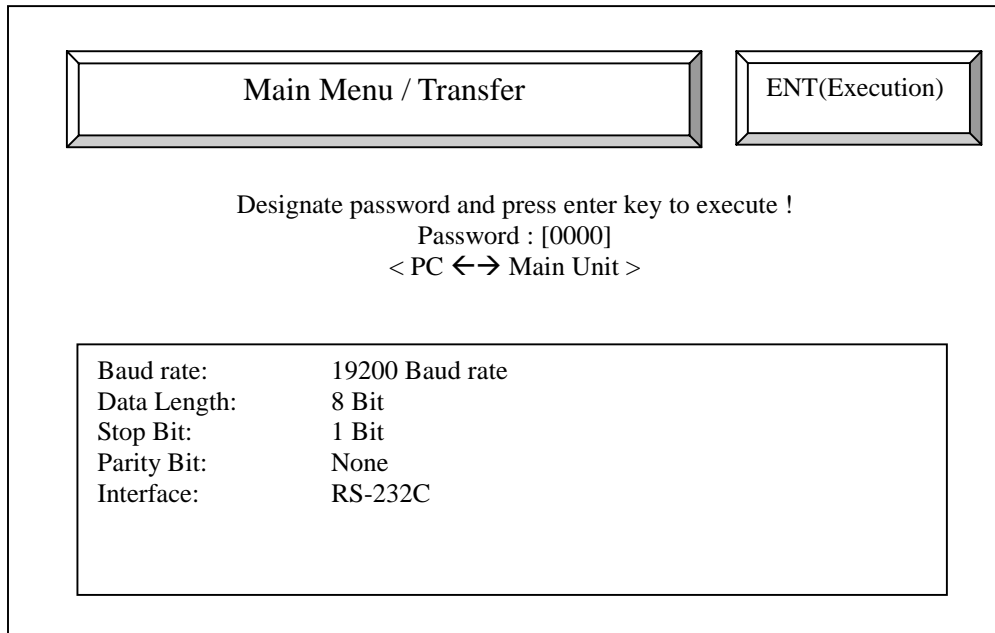

[Drawing. PC ↔ Main Unit]

3-3-1. PC ↔ Main unit

Transfer screen files created in PMU Master S/W to the Main unit.

A user can not only download files from PMU Master S/W to the main unit but also upload to the PC. This files for transfer should be *. prj files(project files).

(Operating method)

- 1) Press F3 function key or 'F3 Transfer' touch key in the transfer mode.
- 2) Enter a password (If user lost a password enter new password in initial setup/system setup mode.)
- 3) Press Enter key to be ready
- 4) Transfer the files to the main unit using the project manager of the PMU Master S/W.
(Please refer to the Software manual for PC Operation)
You can see the message "Executing transfer..."
- 5) After completion, The data is saved to the internal memory with the message 'memory write'.
- 6) 'Completed! <KEY>' message is shown to the main unit after execution.
- 7) To interrupt transfer, press ESC key.

3-4. Simulation

3-4-1. Simulation

This function is used when a user wants to confirm how the created screen will actually operate in PC or PMU main unit.

The simulation mode has a dialog box writing buffer value, which will get from PLC in operation mode, using keyboard.

This function is so useful to check the registered tag before installing the main unit to a plant line or panel.

The initial screen registered in the main unit displays in simulation mode.

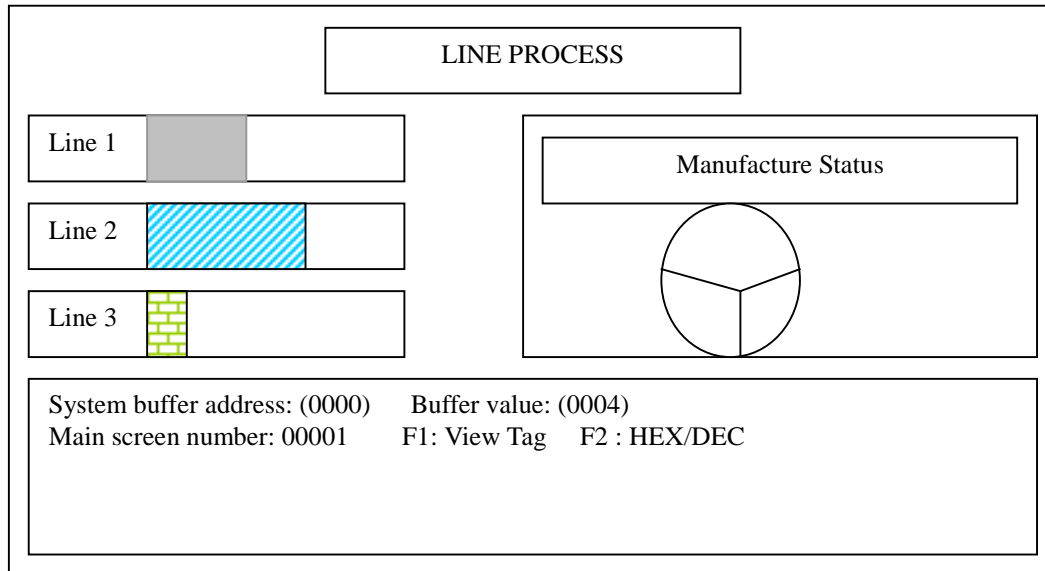

(Operating Method)

- 1) Select "Simulation mode" in the main menu or F4 function key. Then you will find main screen (Initial screen) registered in operation setup mode and dialog box to enter data for simulation.
- 2) To enter data to a system buffer,
 - Press T/F function key (then user will find the LED of T/F gets on.)
 - After enter the system buffer address, press Enter key. Then the data will be shown to a user with hex, binary or decimal code.
 - When a user enter data to a system buffer, just enter the data if the data is decimal code. But it is hex code, user should use hex code after open the Hex key using touch key.
- 3) To change the position of dialog box, press direction key after the LED of T/F get On. Then the position will be changed into Up, Down position or Not shown.

- 4) To escape from the simulation mode, press ESC key. Then the message “ Exit [F1(Y)/F2(N)]? ” displays.
To go back to main menu, Press F1 function key.

3-4-2. View Tag list in the simulation mode

A user can view the list of tags displayed in simulation mode.

<View Tag list>

Tag Name	System buffer address
G10	40
G11	41
G100	42

To continue [Enter], To cancel [ESC]

Operating method

- 1) Press “T/F key” in the simulation mode and “FUN” key. Then the tags registered in the main screen will be shown. Each Tag lists will be shown to the list by Enter key.

(Tag list order)

1. Numeric Tag 2. Auxiliary Tag 3. Symbol tag 4. Touch tag 5. Key tag 6. Key display tag 7. Level graph tag 8. Statistic tag 9. Area move tag 10. Precision adjust tag 11. Buffer write tag 12. Move tag 13. Message tag 14. Trend tag 15. Lamp tag 16. Delay tag 17. Computation tag 18. Block tag 19. Function key tag 20. Pie graph tag

- 2) To cancel, press “ESC” key from the simulation mode

3-5. Run

Sending and receiving between main unit and PLC use system buffer address of PMU.

Data of system buffer indicate graphics or texts displayed in the main screen.

PLC can only write data to system buffer area or read data from system buffer area.

Confirm the following items before operation.

- 1) Designate initial setup and communication setup correctly in the main unit.
- 2) Confirm the connection between PLC and main unit.
- 3) Confirm the screen data , which created in PMU Master s/w, in simulation mode before transfer the data to main unit.

[Appendix]

A.SYSTEM BUFFER

A-1. Definition

System buffer is memory area saving screen control data or error information necessary to operation mode. It consists of 1024 system buffer memories. All data for communication will be saved into system buffer area.

A-2. System buffer Map

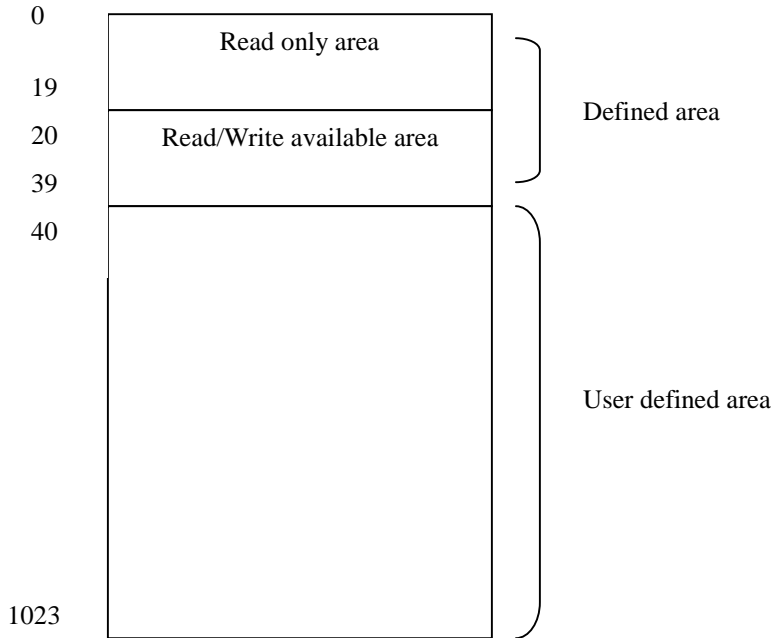

A-3. Description of System buffer

- Read-only System defined buffer

Buffer address		Bit	Contents	
0	System error	0	System ROM Error	
		1	System RAM Error	
		2	Flash Memory Error	
		3	Ask Flash Memory Initialization	
		4	Character ROM Error	
		5	Auxiliary CPU Error	
		6	Clock Error	
		7	Touch Key Error	
		8	Printing	
		9	Function Key Error	
		10-15	Not Used	
1	Serial comm. error	0	Frame error	
		1	Parity error	
		2	Overrun error	
		3	Time out error	
		4	Protocol error	
		5	Check sum error	
		6-15	Not used	
2-6	Fnet error information	0-15	Fnet information	
7	Not used	0-15	Reserved area	
9	Year	0-15	Clock	Year (BCD 16bits : 2 digits)
10	Month	0-15		Month (BCD 16bits : 2 digits)
11	Date	0-15		Date (BCD 16bits : 2 digits)
12	Hour	0-15		Hour (BCD 16bits : 2 digits)
13	Minute	0-15		Minute (BCD 16bits : 2 digits)
14	Second	0-15		Second (BCD 16bits : 2 digits)
15	Fixed value	0-15	When power is on, it always keeps 0 value.	
16	Fixed value	0	When power is on or changes screen, 0 → 1 No.0 bit will be always on.	
17		0-15	Reserved area	
18	System clock	0-15	1 second clock	
19	Aux. Input buffer	0-2	Data from auxiliary port (8bits)	

- Read/Write System defined buffer

20	Main screen number	0-15	This buffer can save main screen number to be displayed. If a user wants to change screen into another, enter the screen number to be changed to this buffer.
21	Key display	0-15	Data for Key display tag (lower word)
22	Key display	0-15	Data for Key display tag (upper word)
23	TenKey Enter information	0	When press [enter] key of tenkey, 0 bit will be 1.
24-25		0-15	Reserved area
26	Call previous screen	0-15	If data of this buffer is not '0', it calls previous screen.
27	Exit	0-15	If data of this buffer is not '0', Operation will be end.
30	Buzzer output time	0-15	Buzzer output time of auxiliary port
31	Aux. Output information	0-7	Output data (8 bit)of auxiliary port
32	Screen Off setup	0-15	If data of this buffer is not '0', Backlight will be Off.

- User defined buffer

Read/Write available in this buffer area: 40 ~ 1023 buffers

B. Application examples

B-1. PLC Communication specification

B-1-1. PLC Types and communication method

1:1 communication

Serial interface (RS232C, RS422), Datalink, User defined protocol

Method	Comm. mode	PLC Type	PLC CPU type	Comm. Interface module
	Serial Interface	Master-K Series	Master K500/1000 CPU	
		GLOFA-GM	GOL-CPU	
		GLOFA-K		
		Mitsubishi(A2N, A3N)		AJ71UC24
		Mitsubishi(A1S)		
		OMRON	C200H	
		Samsung FARA		
		Fuji PLCs		FFU120B, FFK120A
		LG Inverter		
		AB PLCs(DF1 protocol)		
		Modicon(Modbus)		
	Data Link	Master-K200H		DLU module
		FAM 3.1, 4.0		
User defined	-			

B-1-2. Setup items

B-1-2-1. Serial setup items (1:1 Comm.)

Baud rate	300, 600, 1200, 2400, 4800, 9600, 19200,38400
Data Bit	7 bit, 8 bit [Note] Master-K : 8 bit
Stop Bit	1 bit, 2 bit [Note] Master-K : 1 bit
Parity Bit	No parity, Odd parity, Even parity [Note] Master-K : No parity
Interface	RS232C, RS422
Station no.	0-31 Stations
Check sum	Always Yes (Except for Micrex)

B-1-2-2. Data Link setup items

Setting of Station Number	0 to 125 stations
Setting of High Speed Data	Setting buffer numbers for each of input/output data

[Note] No. of Input and output data for setup are max. 64. But, limited up to 32 words when user uses both of

input and outputs simultaneously.

[Note] Buffer number should be between 0 to 1023.

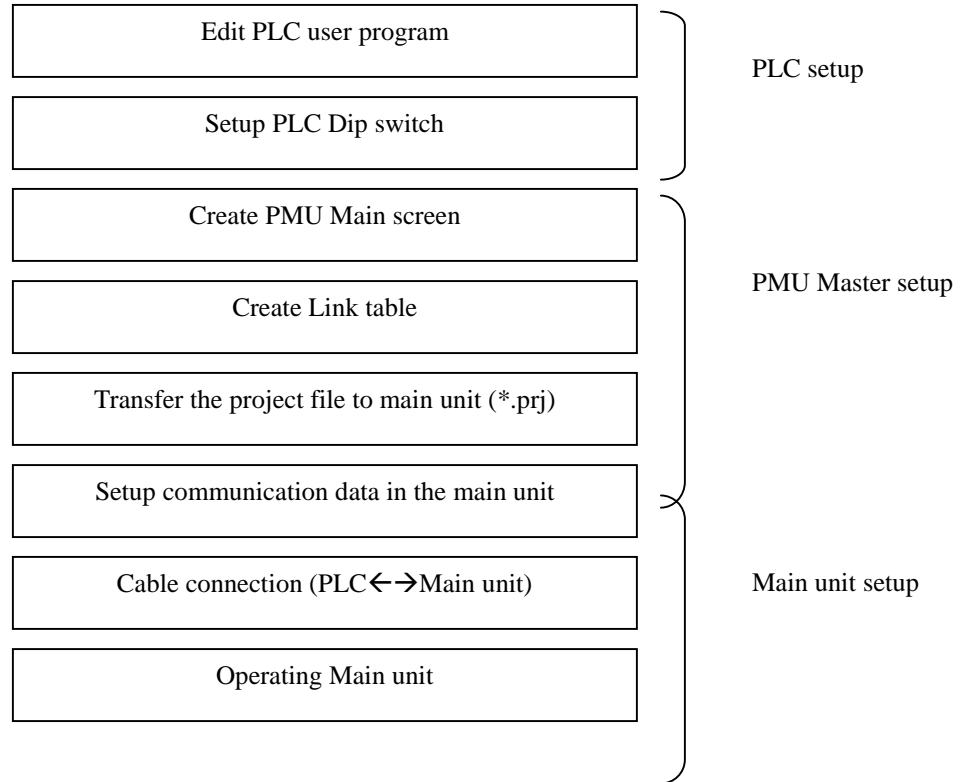
B-2. PLC Communication flow chart.

B-3-1-2. Master-K 101S, 30S, 60S, 100S

B-3-1-2-1. PMU main unit Setup

Operation mode setup

Operation mode setup

- Select [Initial Menu] → [Operation Setup]
 [Initial screen number]: 0-999 select
 [Power On initial mode]: Initial menu or Operation
 [Memory type]: Internal memory or Memory card

Serial mode setup

Baud rate	300 bps, 600 bps, 1200 bps, 2400bps, 4800bps, 9600bps, 19200bps , 38400bps
Data bit	8 Bits
Stop bit	1 Bit
Parity bit	None
Serial Interface	RS232C (Loader port)
Station Number	None

Link Editor (PC→ PMU Main unit)

- Select Master-K S/H series
- In link table, setup PLC Device, Buffer, Word and Station number
- Please refer to Master-K S/H type address allocation table
- Please refer to Link editor for the detail information.

B-3-1-2-2. PLC Setup

Hardware Dip switch select (Master-K S/H Series)

Master-K S Series can do communicate with PMU main unit through RS232C interface using loader port.

Baud rate will be fixed with 9600 bps

B-3-1-2-3.PLC Address allocation table (Master-KS/H Series)

Memory area	Address		
	K10S,K30S,K60S,K100S	K10S1	K60H, K200H
Auxiliary Relay (M)	M0000-M0031	M0000-M0015	M0000-M0063
I/O Relay (P)	P0000-P0005	P0000-P0001	P0000-P0255
Keep Relay (K)	K0000-K0015	K0000-K0007	K0000-K0511
Link Relay (L)	L0000-L0015	L0000-L0007	L0000-L0255
Special Relay (F)	F0000-F0015	F0000-F0015	F0000-F0255
Timer- current value (T)	T0000-T0127	T0000-T0047	T0000-T0255
Counter-current value (C)	C0000-C0127	C0000-C0015	C0000-C0255
Data Register (D)	D0000-D0255	D0000-D0063	D0000-D1023

B-3-1-2-4. Cable connection (PMU↔ PLC)

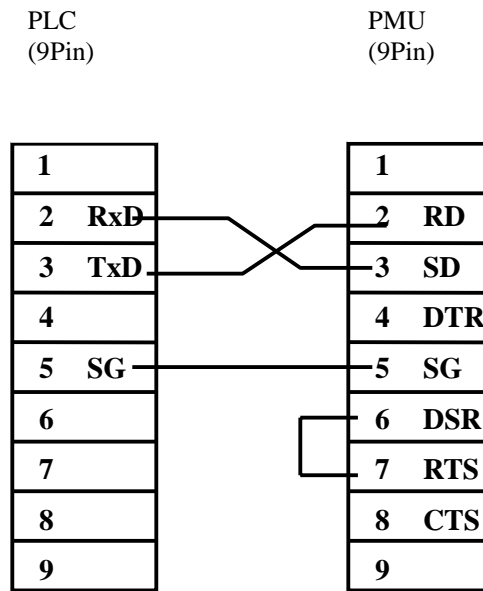

B-3-1-3. GLOFA-GM Cnet Setup

B-3-1-3-1. PMU main unit setup

Operation mode setup

- Select [Initial Menu] → [Operation Setup]
 [Initial screen number]: 0-999 select
 [Power On initial mode]: Initial menu or Operation
 [Memory type]: Internal memory or Memory card

Serial mode setup

Baud rate	300 bps, 600 bps, 1200 bps, 2400bps, 4800bps, 9600bps, 19200bps , 38400bps
Data bit	8 Bits
Stop bit	1 Bit
Parity bit	None
Serial Interface	RS232C (Cnet module)
Station Number	None

Link Editor (PC→ PMU Main unit)

- Select GLOFA-GM (Cnet) series
- In link table, setup PLC Device, Buffer
- Please refer to GLOFA-GM(Cnet) address allocation table.
- Please refer to Link editor for the detail information

B-3-1-3-2. PLC Setup

Hardware Rotary switch select (GLOFA-GM Cnet)

Mode	Description
1	RS232C Mode
3	RS232C / RS422 Mode
4	RS422 Mode
5	RS232C Mode
7	RS422 Mode

* Station number setup: Use Frame editor software*

* PMU Communication: Select 3 mode(RS232C/RS422 mode)

B-3-1-3-3. PLC Address allocation table (GLOFA-GM)

Type	Word	Address Map
GM1	%IX	%IW0.0.0 ~ %IW63.7.3
	%QX	%QW0.0.0 ~ %QW63.7.3
	%M	%MB0 ~ %MB65535
GM2	%IX	%IW0.0.0 ~ %IW31.7.3
	%QX	%QW0.0.0 ~ %QW31.7.3
	%M	%MB0 ~ %MB65535
GM3	%IX	%IW0.0.0 ~ %IW7.7.3
	%QX	%QW0.0.0 ~ %QW7.7.3
	%M	%MB0 ~ %MB32767
GM4	%IX	%IW0.0.0 ~ %IW7.7.3
	%QX	%QW0.0.0 ~ %QW7.7.3
	%M	%MB0 ~ %MB16383
GM5	%IX	%IW0.0.0 ~ %IW1.9.3
	%QX	%QW0.0.0 ~ %QW1.9.3
	%M	%MB0 ~ %MB8191

Example: %MW0000
 %Q(I)W0.0.0

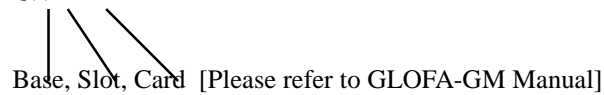

B-3-1-3-4. Cable connection (PMU↔PLC)

RS-232C connection (9 Pin port)

Pin No.	Description	Signal	Direction
1	Carrier Detect	CD	
2	Sending Data	SD(TXD)	—————>
3	Receiving Data	RD(RXD)	<—————
4	Data Terminal Ready	DTR	—————>
5	Signal Ground	SG	
6	Data Set Ready	DSR	<—————
7	Request Sending	RS(RTS)	—————>
8	Confirm Sending	CS(CTS)	<—————
9		RI	

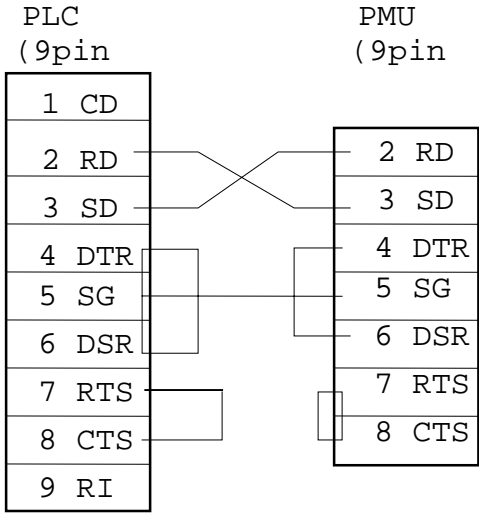

RS-422 connection (6 Pin Port)

Pin No	Description	Signal	Direction
1	Receiving Data A	RDA	←
2	Receiving Data B	RDB	←
3	Sending Data A	SDA	→
4	Sending Data B	SDB	→
5	Signal Ground	SG	
6	Frame Ground	FG	

