

1. Overview

1-1-1. Introduction

This User's manual describes the specifications, handling, utility functions and other information of PMU-600 Programmable Monitoring Unit.

PMU-600 is the operating panel with touch screen to replace originally used operation panel such as switch operations and displays of data, lamps and messages. It makes user realize CIM (Computer Integrated Manufacture) easily using FA monitoring equipment like PMU series.

1-1-2. Features

1) Windows based software package for screen editing (Windows 3.1, Windows 95 and Windows NT^{*1})

Project Manager

Screen Editors: Main and Sub Screen Editor

Symbol Editor, Alarm Editor, Message Editor and Link Editor

2) Simulation to debug screen editing without connecting PLC and/or PMU main unit

The graphic software supports simulation function how the screen is operating well.

So user can debug the screen simply without any connection between PLC or PMU main unit.

3) Various Interfaces for other PLCs

- Serial interface(RS232C/RS422)

- LG PLCs-(GLOFA-GM, GLOFA-K, Master-K Series)
- Fuji PLCs-(MICREX series)
- Mitsubishi PLCs-(MELSEC series)
- OMRON PLCs (SYSMAC series)
- Matsushita PLCs-(FARA series)
- AB PLCs-(PLC-5/SLC-500 series with DF1 protocol)
- Modicon PLCs-(Quantum series with Modbus protocol)
- LG Inverters

^{*1} windows is a registered trademark of Microsoft Corporation.

- High speed communications
Data Link : Master-K series, FAM(Factory Automation Manager)
- User defined Protocol communication

- 4) Display components
TFT-LCD(Thin Film Transistor Liquid Crystal Display), EL(Electro Luminescent) COLOR,
EL-MONO

- 5) Abundant Diagnosis
 - Touch keys check
 - Font check,
 - Memory card check
 - Check of OS(Operating System) area of internal memory
 - Alarm history check
 - CPU communication check

- 6) Easy interface for user
Matrix Touch Panel (16 x 12 keys)
User defined Function keys (F1 ~ F12)

1-2. Hardware Structure

1-2-1. Partial Names and Functions

A	Display	Components : TFT-LCD, EL COLOR, EL-MONO Touch screen : 32 x 24 matrix(20x20 dots : one full-width character)
B	Function Keys	F1 ~ F12 : User defined function keys
C	Power /Run LED	Power ON, Operation mode
D	Power Input	AC110/220V
E	ON/OFF Switch	Power supply switch
F	Auxiliary I/O ports	4 Inputs(3: DI points, 1: Reset point), 8 Outputs(3 : DO points, 1: Alarm output, 1: Buzzer output, 1: Run output)
G	RS232C port	Serial port(9pin port)
H	RS422 port	SD+,SD-,RD+,RD-SG,FG
I	DLU port	Data Link Communication port for MK series
J	Fnet(fieldbus) port	Fieldbus port for GLOFA GM series
K	PS2 type keyboard connection	For parameter edit or data input in simulation mode using keyboard.
L	Memory card port	External memory card for data backup(512k bytes)

1-2-2. System Configuration

➤ RS232C/RS422

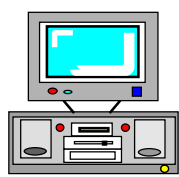

Graphic software package

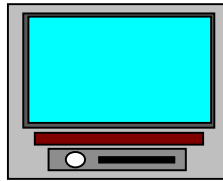
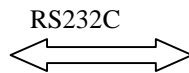

AUX I/O port

GLOFA K series
Master K series : Master-K10S, 30S, 60S

FUJI PLCs (MICREX series)
Mitsubishi PLCs (MELSEC series)
OMRON PLCs (SYSMAC series)
Mat Matsushita PLCs (FARA PLCs)

- Data link
- User defined protocol communication

1-3. Procedures to prepare for starting operation
Procedure for editing screen in PC based software and PMU main unit.

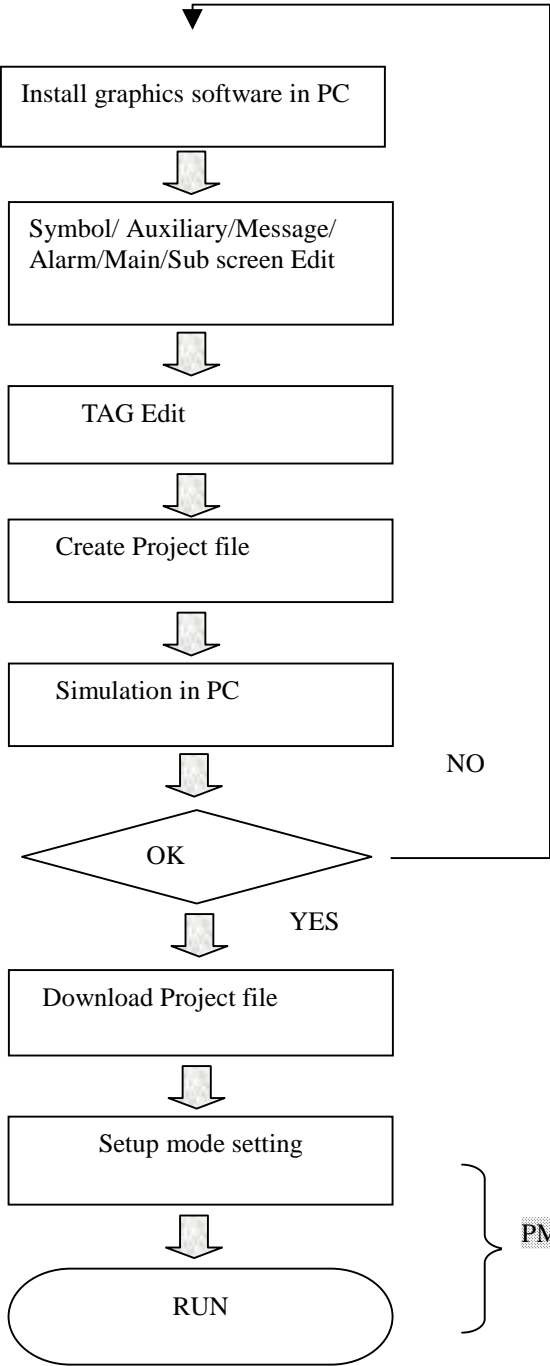

PMU MASTER SOFTWARE

- 1) Create Symbol/Screen(main/sub)/Message/Alarm Editors for start operation
- 2) Add the Tags to the graphics of the main screen editor.
- 3) Test the created screen in the simulation mode of the main screen
- 4) Create project file including all files (*.scr, *.alm, *.lnk, *.msg etc.) what you download to the PMU main unit
- 5) Download project file(*.prj) to PMU main unit using project manager
- 6) Setup mode setting in the PMU main unit
- 7) RUN

PMU HARDWARE

1-4. Types of Tag functions

Functions	Contents
N Tag (Numeric Tag)	This function displays data stored in word devices of PLC
A Tag (Auxiliary Tag)	This function displays graphics or messages from the already created sub-screen onto the main screen.
S Tag (Symbol Tag)	This function displays the already created symbols from symbol Editor onto the main screen.
T Tag (Touch Tag)	This function writes specified value to a word device or turns on a specified bit device when a touch key is touched.
K Tag(Key Tag)	This function is used for entering numeric data like ten-key and user Create a touch key such as a number value key on the sub-screen. (available screen file numbers : 900 ~ 999)
V Tag(Key indicator Tag)	This function makes the numeric values by a key tag displayed onto the screen. It also should be saved as after sub-screen number 900(ex:900.sub)
G Tag(Graph Tag)	This function displays the data stored in multiple word devices as a bar or closed line.
H Tag(Window Tag)	This function switches to a specified window screen when a touch tag is touched.
F Tag(Function key Tag)	This function can use 12 function keys of PMU main unit. This function writes specified value to a word device or turns on a specified bit device when a function key is touched. User defines them.
W Tag(Buffer write Tag)	This function writes specified data or bit to a designated system buffer.
D Tag(Delay Tag)	According to the operating condition, it writes specified value or turns on A specified bit device after the designated timer is On.
B Tag(Block Tag)	This function enables not to be touched by establishing the territory.
M Tag(Message Tag)	This function enables designated message from the message editor to be displayed as bit or word devices are turned on or off.
I Tag(Precision Adjust Tag)	This function enables data of designated system buffer to be precisely adjusted or send output data to auxiliary port in the PMU main unit.
L Tag(Lamp Tag)	This turns lamps on and off in conjunction with bit devices being turned on and off from PLC. Lamp color can be changed to any of colors.
X Tag(Trend graph Tag)	This function allows the data stored in a word device to be collected at a specified timing and displayed as a trend graph. After the data is displayed to the specified range, the display scrolls.
C Tag(Computation Tag)	This function enables data computed by condition to be entered into the specified buffer.
J Tag(Move Tag)	This function enables a already created symbol in symbol editor to be displayed onto a main screen in accordance with the specified buffer criteria.
R Tag(Area move Tag)	This function enables a symbol to be displayed by the designated position based on the value of a 2-point word device.
P Tag(Pie Tag)	This function shows the data stored in word devices as a pie or meta graph.
Q Tag(String Tag)	This function writes data from PLC as a string of ASCII code.
E Tag(Statistic tag)	This function shows the percentage of the each data(up to 8) as a circle or rectangle in accordance with the changeable system buffers.

2. Specifications

2-1. General specifications

Items	PMU-600T	PMU-600C	PMU-600E
Input power	AC85 ~ 132V or AC170 ~ 264V , 50~60Hz		
Power consumption	Less than 56VA		
Noise withstand resistance	Impulse noise voltage : 1,200Vp-p □ (50/60Hz 1minute)		
Insulation resistance	500VDC at 10MΩ		
Ambient operating temperature	0~40□	- 5~55□	- 5~55□
Ambient storage temperature	-20~60□	-20~75□	-20~75□
Ambient operating humidity	40□, 85%RH	40□, 93%RH	40□, 93%RH
Environment	No corrosive gases		
Vibration endurance	10 to 25 Hz(X,Y,Z direction 2G 30 minutes)		

2-2. Performance specifications

Items	PMU-600T	PMU-600C	PMU-600E/M
Display component	TFT color LCD 16 colors	EL Color 8 colors	EL-Mono Yellow
Resolution	640 x 480 Dots		
Screen size	211.1 x 158.3 mm(10.4 inch)		
Display properties	Normal, Toggle, Blink		
Text enlargement	1~8 times(width x height each)		
Types of graphics	Line, Polyline, rectangle, Circle, Oval, Painted rectangle, Arc, Pie, Text, Clock		
Type of graph	Bar, Trend, Closed line, Statistical, Pie and Meter graph		
Screen numbers	999 (main/sub/symbol/alarm/message each)		
Touch panel	Pressure matrix method(32x24 touch cells)		
Touch key size	20 x 20 dots (minimum)		
Auxiliary I/O ports	4 Inputs(3: DI points, 1: Reset point), 8 Outputs(3 : DO points, 1: Alarm output, 1: Buzzer output, 1: Run output)		
Communication Interface	RS232C/RS422, Fnet, Datalink, T-link		
Keyboard	IBM PC/AT compatible		
Printer	Centronix standard compatible		
Memory card	512 k Bytes Flash memory(BN-512HFR(Panasonic))		
Function keys(Hardware)	F1~F12		

2-3. Auxiliary I/O Specifications

Items	Specifications	
Input points	4 points(Data 3 points, Reset 1 point)	
Rated input voltage	DC24V(DC19.2 ~ DC30V)	
Input Current	10mA	
Delay time	ON	10mA
	OFF	15mA
Common	Input data common(DC24V+)	
Insulation method	Photo-coupler insulated	
External connection	Connector type	

Items	Specifications	
Output points	11 points(Data :8 points, Run :1point, Buzzer :1point, Alarm: 1point)	
Rated input voltage	DC24V(DC19.2 ~ DC30V)	
Output Current	10mA	
Delay time	ON	Less than 1msec
	OFF	Less than 1msec
Common	GND	
Insulation method	Photo-coupler insulated	
External connection	Connector type	

2-3. Auxiliary I/O pin assignment

Pin No.	Signal	Contents	Pin No.	Signal	Contents
1	Alarm	Alarm output	14	DO(7)	Data output 8 points
2	BUZ	Buzzer output	15	DO(6)	
3	RUN	Run output	16	DO(5)	
4	N.C.	No connection	17	DO(4)	
5	DICOMM	Output common (GND)	18	DO(3)	
6	DICOMM		19	DO(2)	
7	DICOMM		20	DO(1)	
8, 9, 10	N.C.	No connection	21	DO(0)	
11	SWCOMM(24V)	Input common (24V)	22	Reset	Reset point
12	SWCOMM(24V)		23	SI(2)	Data Input 3 points
13	SWCOMM(24V)		24	SI(1)	
			25	SI(0)	

2-4. Communication Specification

2-4-1. Datalink Communication

- Baud rate : 1 M bps
- PLC connection and PMU station number
 - Maximum 32 PMUs
 - Station number: 1 ~ 125 station
- The number of words to be connected per station
 - Remote I/O: Send: max. 32 words, Receive :max. 32 words
 - Remote Input: Receive: max. 64 words
 - Remote Output: Send: max. 64 words

2-4-2. Serial communication

- Baud rate : 300, 600, 1200, 2400, 4800, 9600, 19200 bps
- Data bits : 7bits, 8bits

[Note] Master-K series: 8bits

- Stop bits : 1, 2 bits

[Note] Master-K series: 1bit

- Parity bits : None, Odd, Even Parity

[Note] Master-K series: None parity

- Interface : RS232C, RS422
- Self station number : 0~31 station

[Note] Master-K series: 0~15 station

- Check sum : Yes, No

[Note] Micrex(Fuji) : No

2-5. Installation

 Please avoid location to be installed listed below.

- Locations where the temperature changes drastically and condensation occurs.
- Locations where the main unit is exposed to direct sunlight, vibration or impact.
- Locations where strong electrical or magnetic fields are generated.

Earth

- The FG and LG port of the PMU main unit should always be grounded using the Class 3 Ground. Failing to ground these ports sufficiently could cause electrical shock and malfunctioning.
- The cable for earth should be more than 2 mm².
- The earth point is closer to the PMU main unit and the cable is shorter if possible.

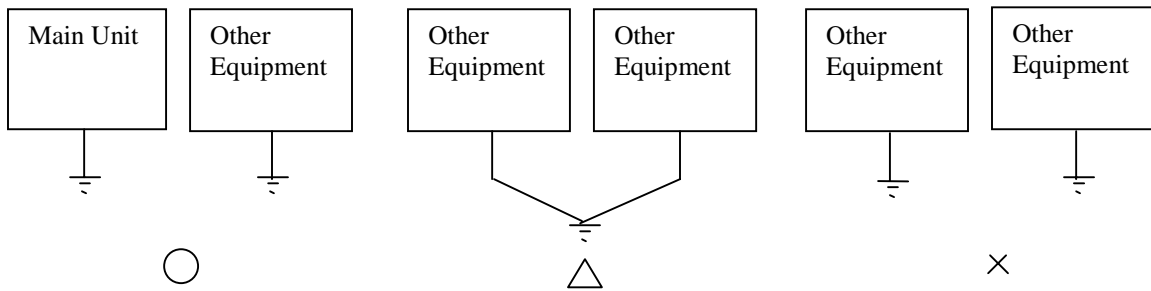

3-1. Main menu structure in PMU main unit

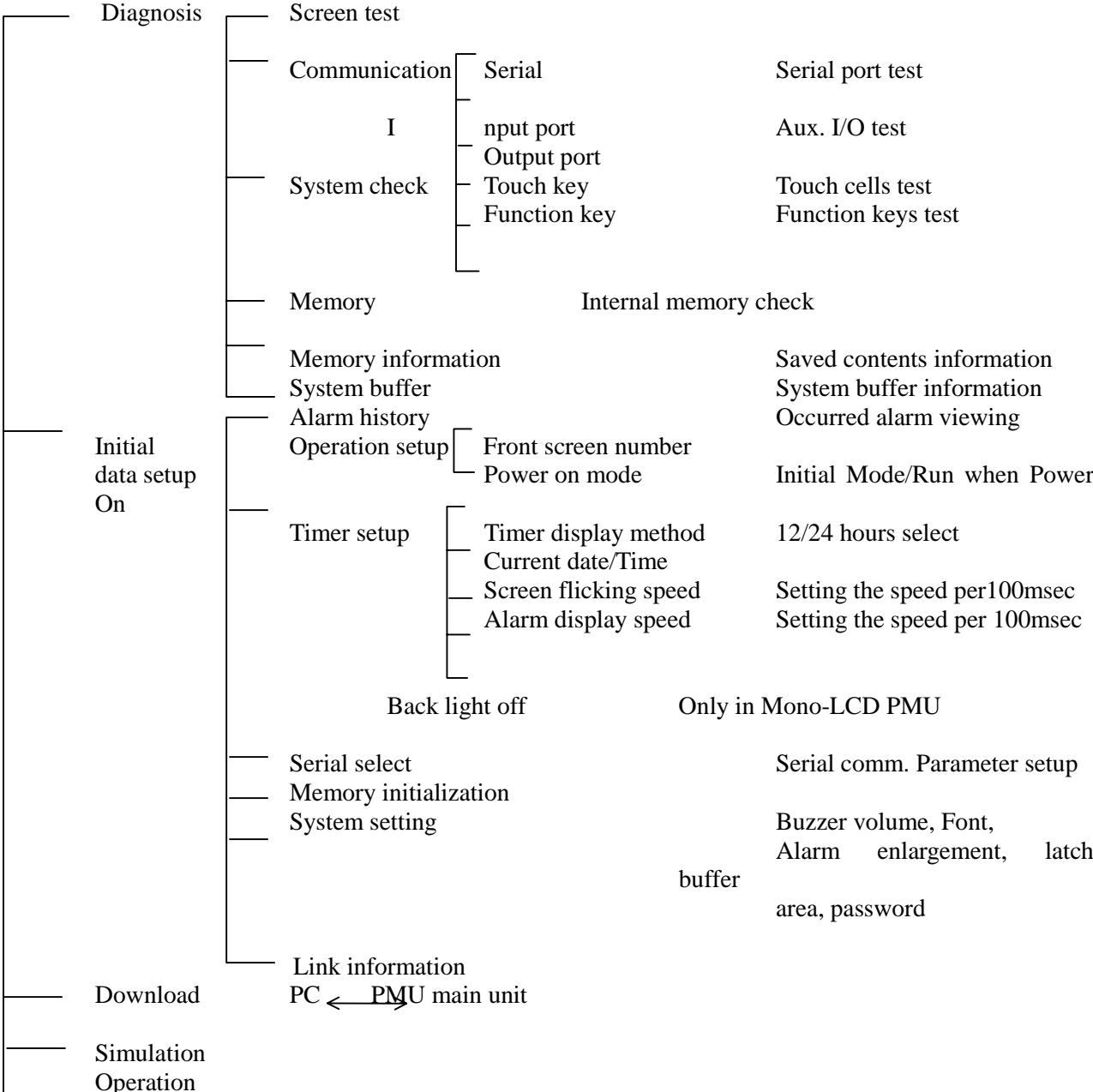

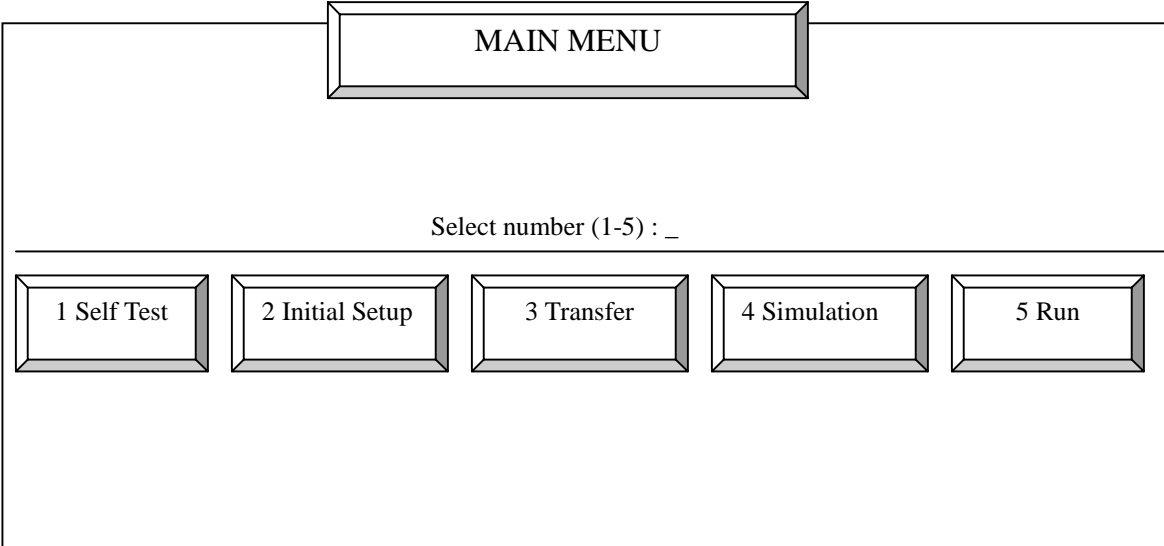

- Main Menu -

3-1. Diagnosis

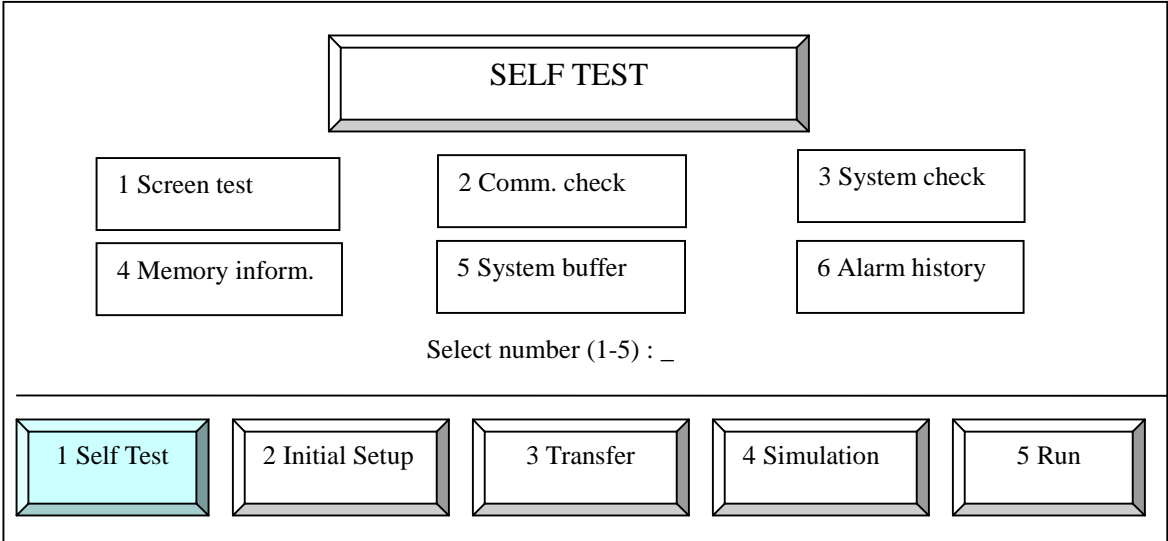

- Diagnosis -

3-1-1. Screen test

This mode is to check the condition of display device and to check font, color and line type.

- Display Characters

Check the types of characters, size and attributes of characters.

- Line pattern

Each 8 types of line and palette are shown in this mode.

- Graphics display

Check types of graphics like circles, ovals, arc, rectangles, and painted rectangles

- Tag types

Check types of tags like graph, pie, statistical, move, message, trend, numeric and alarm tag

- Device display check

This mode is to check the condition of all touch cells using by on.

To escape from the blank screen, touch the upper left side.

3-1-2. Communication check

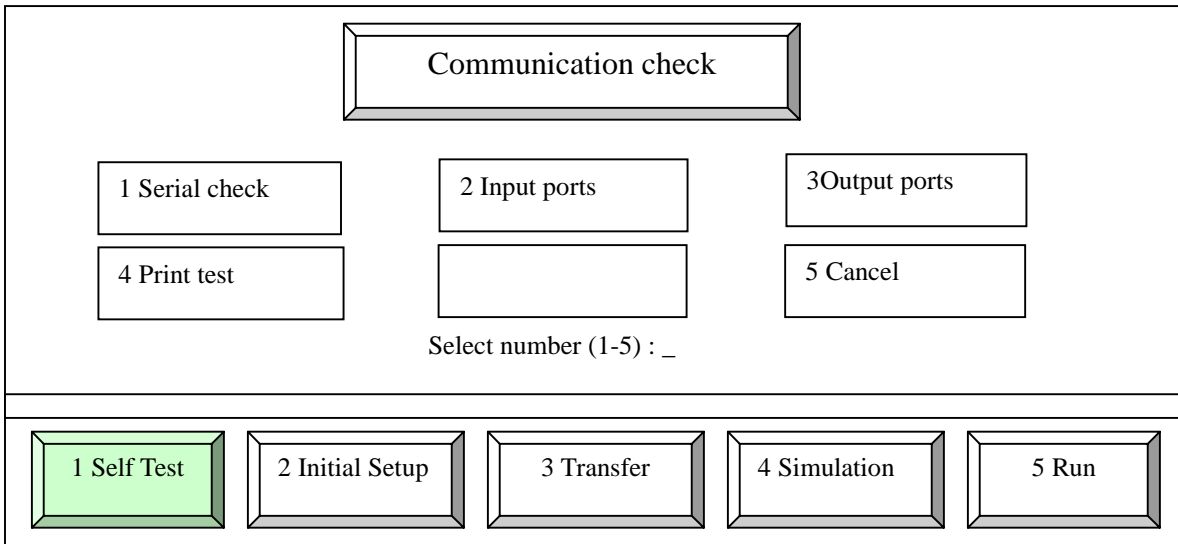

Serial port check (Loop back test)

When push the F1 function key or touch key it shows the condition of RS232C port. It displays the transmitted

characters into ASCII Code. User can test serial port by connecting only RXD and TXD port.

(Test method)

- 1) Push F1 Function key or touch the serial check key
- 2) Connect RXD and TXD port of 9-pin connector and push the Enter key.
- 3) It displays ASCII code in the screen if it's okay.
- 4) If there is a problem it shows the message "RS-232C Port error". Then confirm the port after push the ESC touch key.

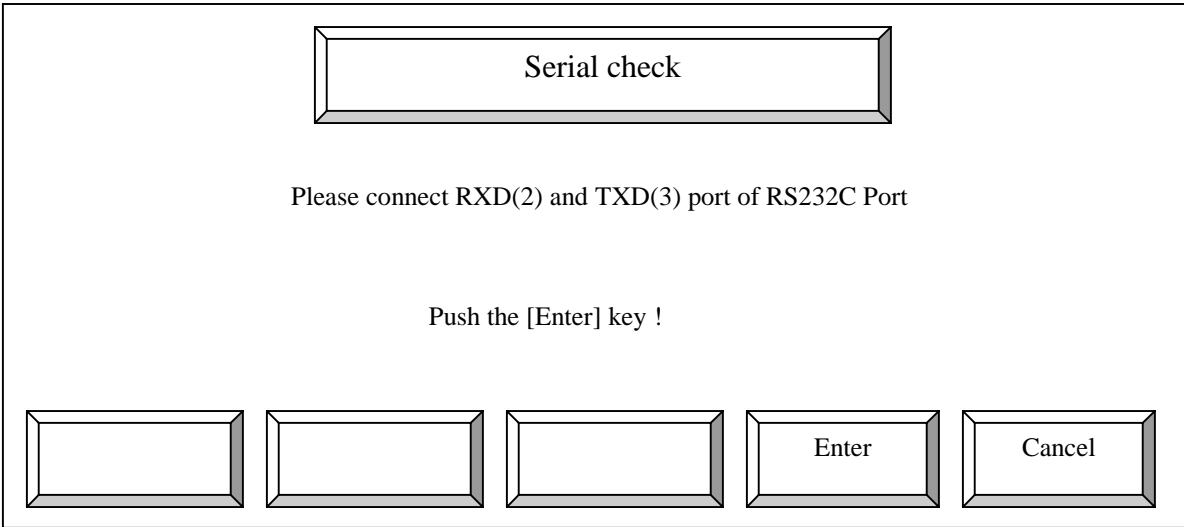

Auxiliary Input ports

This mode shows the ON/OFF condition of input ports in the auxiliary port of the option card.
(Test method)

- 1) Enter the F2 Key or select the Input port test by touch in the comm. Test mode.
- 2) 4 Circles displayed in the screen of the main unit shows the condition of the external inputs.
If it is operated well it will be turned on if not it will be turned off.

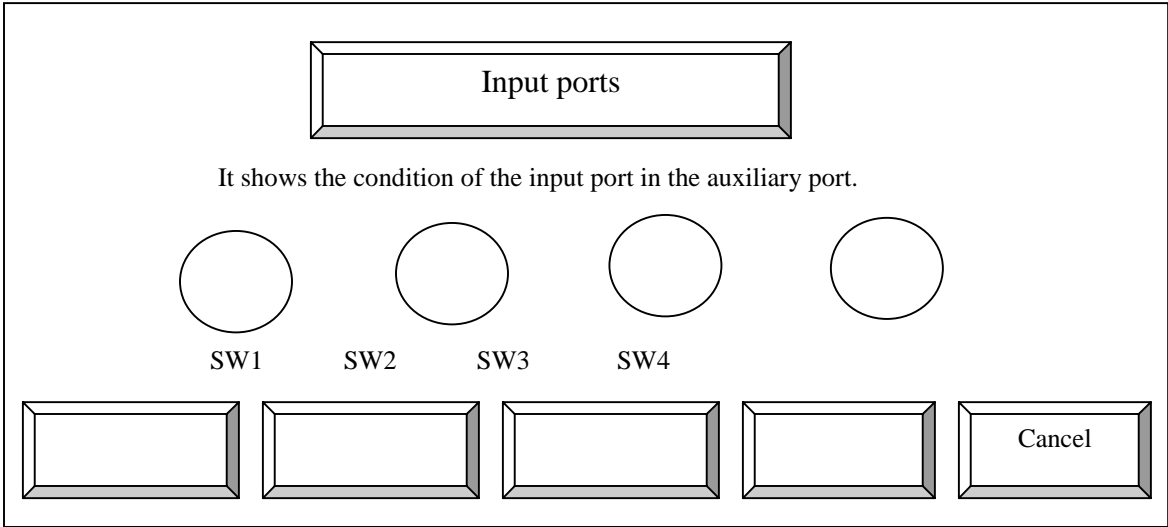

Output ports

This mode shows the ON/OFF condition output ports in the auxiliary port of the option card.

(Test method)

- 3) Enter the F3 Key or select the output port test by touch in the comm. Test mode.
- 4) 11 touch keys displayed in the screen of the main unit shows the condition of the external outputs.
When a user touches the specified touch key among D1~BUZ, it sends the On signal to the output port of the Auxiliary port.

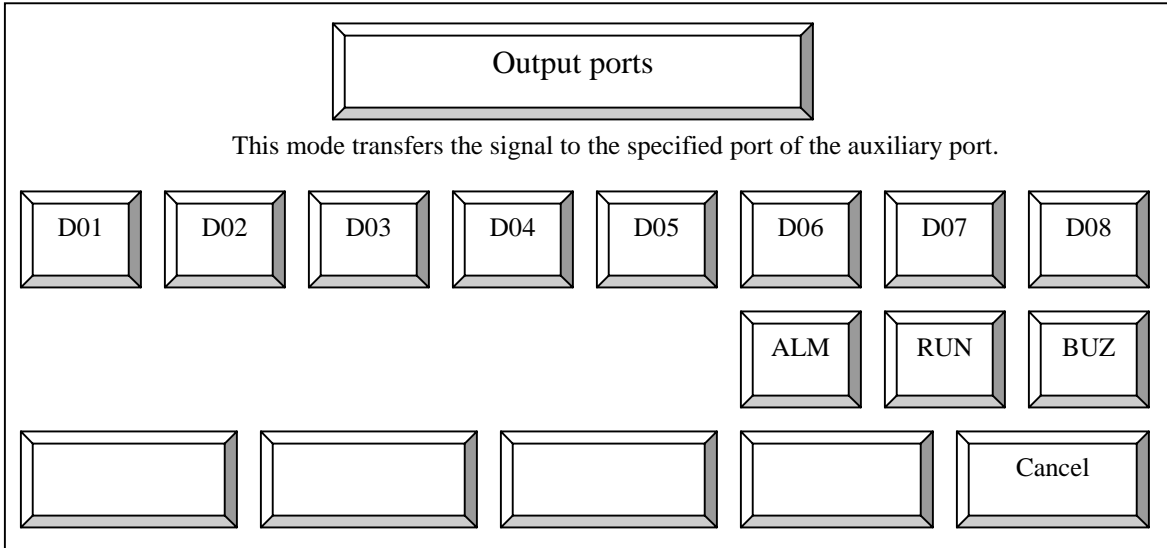

Print check

In this mode a user can do print check by connecting the print to the print port of the option card.

3-1-3. System check

System check mode shows the information about touch key, function key, keyboard input, buzzer, internal memory and memory card.

1) Touch key

A user can confirm that the each touch cells operate well or not by touching the cells in the screen. The size of each cell is 20 x 20 dots and total cell numbers are 32 x 24(768).

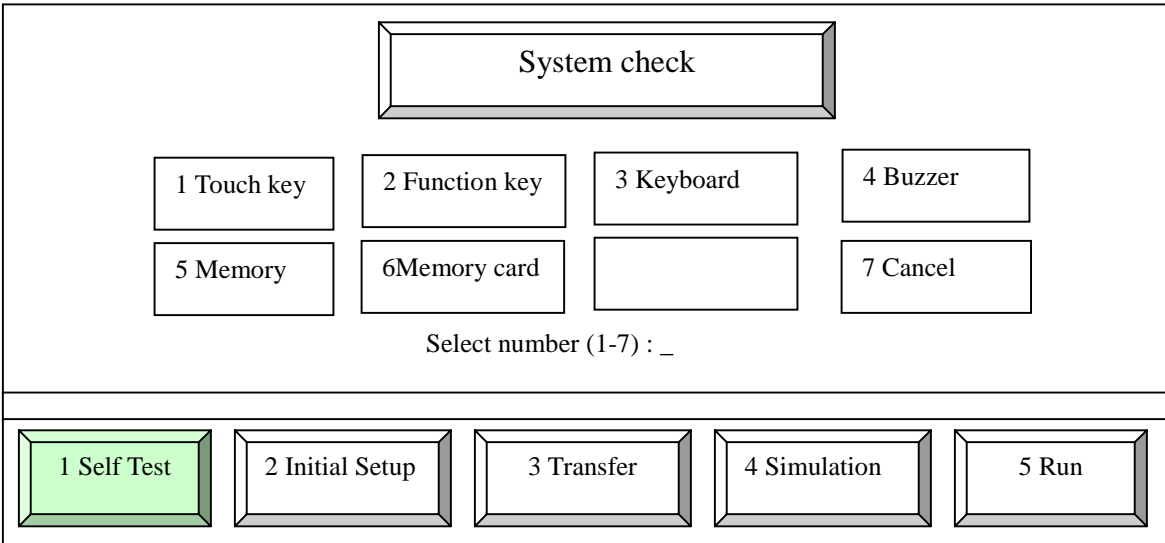

Operating Method

- 1. Select Touch key button in the system check mode or press F1 function key. H
- 2. Displays 368(32x24) touch cells and can test the cells by touching cells.
- 3. Press ESC key or F12 function key to escape from the test mode

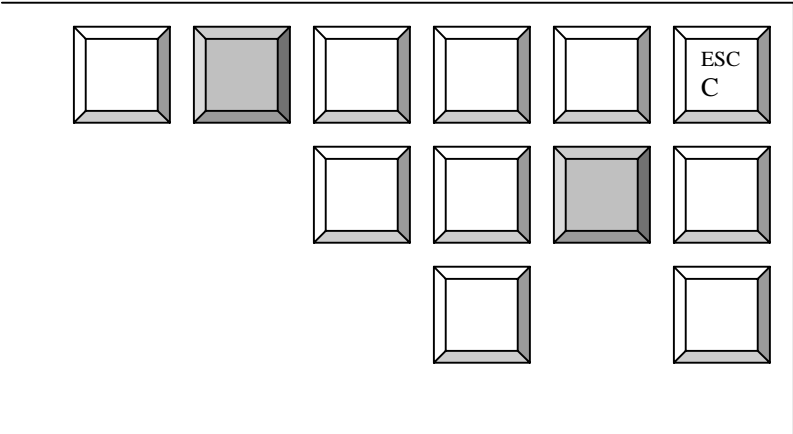

[Drawing 2. Touch key test screen]

2) Function Key

This mode diagnoses the operating condition of function keys. It displays ON/OFF condition of F1 ~ F12 keys.

Operating Method

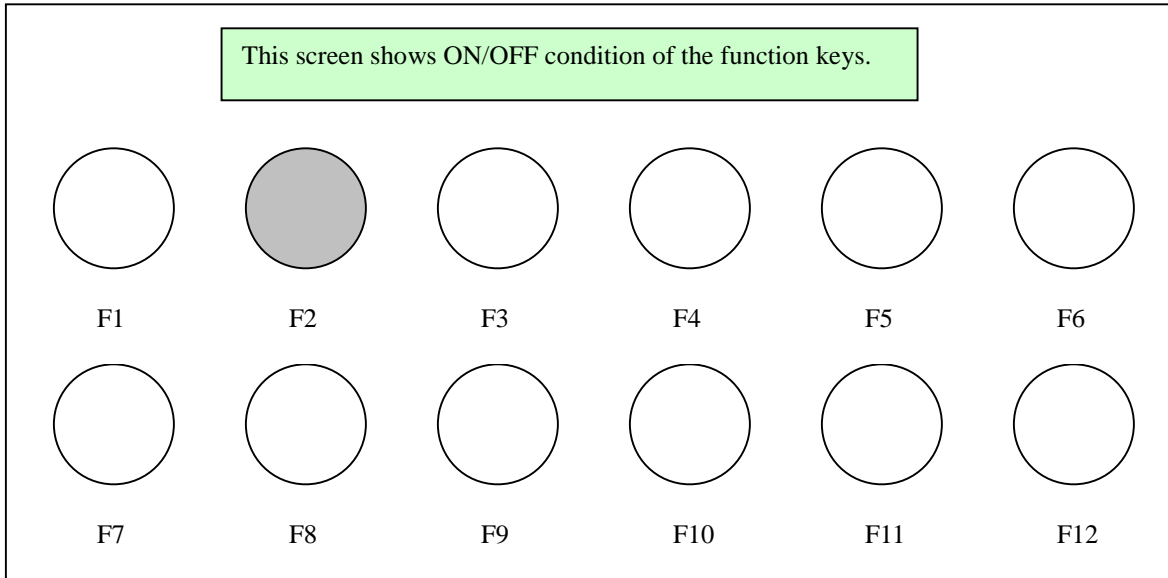

1. Select Function key button in the system check mode or press F2 function key.
2. 12 circles displayed onto the screen are matched with function keys under the main unit and when Push the function keys. Then it displays its own colors.
3. Press ESC key or F12 function key to escape from the test mode.

3) Keyboard test

This mode diagnoses how the keyboard connected to PMU through the PS2 port operates well. Pressed keys of the keyboard shows to the screen.

4) Operating method

1. Select Keyboard button on in the system check mode or press F3 function key.
2. The keyboard shows on the screen and it displays ON/OFF condition when press any keys of the keyboard.
3. Press ESC key or F12 function key to escape from the test mode.

5) Buzzer test

This mode diagnoses the buzzer beep and can adjust the tone and lengt

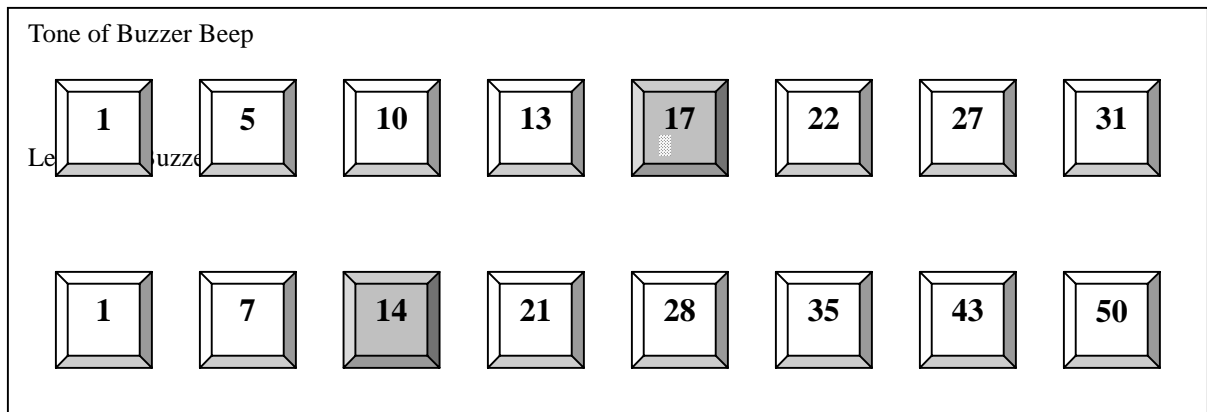

3. It sounds the defined tone and length of the buzzer when touch the touch keys.
4. Press ESC key or F12 function key to escape from the test mode.

6) Memory(Internal memory)

It shows currently used internal memory's contents such as page number, used capacity, unused capacity and contents.

Operating method

1. Select Memory button in the system check mode or press F5 function key.
2. Press ESC key or F12 function key to escape from the test mode.

Page No.	Used memory	Not used memory	Contents
0	63460	02060	Header File data
1	00000	65536	File data
2	00000	65536	File data
3	00000	65536	File data
4	00000	65536	File data
5	00000	65536	File data

File memory capacity: 512 K byte (Unit: byte)

7) Memory card(Flash memory card)

It shows currently used memory contents of the memory card such as page number, used capacity, unused capacity and contents.

Operating method

1. Select Memory card button in the system check mode or press F6 function key.
2. Press ESC key or F12 function key to escape from the test mode.

3-1-4. Memory information

It shows the information of internal memory or memory card.

They are classified into main screen, symbol file and sub screen. The screen displays screen numbers and descriptions for each screen.

Memory Information		
No.	Description	Screen type
301	Lamp test	Main screen
302	Current meter	Main screen
303	Voltage meter	Main screen
401	Line 1	Main screen

Information	Memory	▲	▼	Cancel
-------------	--------	---	---	--------

Operating method

1. Select Memory information in self test mode or press F4 function key then displays the information.
2. When a user wants to get an information about the main screen,
 - Press Information (1) button, F1 function key or “1” with keyboard.
 - (Sub screen : “2” or F2, Symbol file : “3” or F3)
3. When a user wants to get an information about memory card connected to the main unit,
 - Select Memory button(2)
 - Press F2 function key or “2” with keyboard.
4. For a screen move,
 - Press “▲” or “PageUp” of the keyboard
 - Press “▼” or “PageDown” of the keyboard

3-1-5. System Buffer

It shows the contents of system buffer memory such as system buffer no., saved value and description of the buffer. (System buffer area : 0 ~ 39, User defined buffer area : 40 ~1023)

System Buffer				
No.	Binary	Decimal	Hex	Description
0000	0000-0000-0000-0000	00000	00000	System error information
0001	0000-0000-0000-0000	00000	00000	Communication error info.
0002	1111-1111-1111-1111	65535	FFFF	DLU error information
0003	1111-1111-1111-1111	65535	FFFF	Fieldbus error information

Information	Initialize	▲	▼	Cancel
-------------	------------	---	---	--------

Operating Method

- 1) Select System buffer button of the Diagnosis mode or Press F5 function key.
- 2) For next page move,
 - Press “ ▲ ” or “PageUp” of the keyboard
 - Press “ ▼ ” or “PageDown” of the keyboard
- 3) When a user wants to get an information of any buffer,
 - Select Information button below the screen of the main unit.
 - Enter the buffer number with the keyboard.
- 4) When a user make the internal system memory into initial mode,
 - Select “Initial mode”
 - Do you want to clear all data ?(Y(F1)/N(F2))
 - Select Y or F1 key for initial mode.

3-1-6. Alarm History

This mode shows the occurred time and messages and can print the alarm history directly.

Alarm History			
No.	Month:Date:Hour:Minute:Second	E/D	Alarm message
001	07:04:11:47:23	E	Line 1 Error
002	07:04:13:34:42	E	Motor1 Overheat

Print	Initialize	▲	▼	Cancel
-------	------------	---	---	--------

Operating method

- 1) Select Alarm history in the Diagnosis mode or press F6 function key.
- 2) Select "Print" button to print the alarm lists.
- 3) For a screen move,
 - Press "▲" or "PageUp" of the keyboard
 - Press "▼" or "PageDown" of the keyboard
- 4) When a user make the saved alarm history into initial mode,
 - Select "Initial mode"

3-2. Initial mode setup

This mode set operation setup, time/date, system setup and memory initialization.

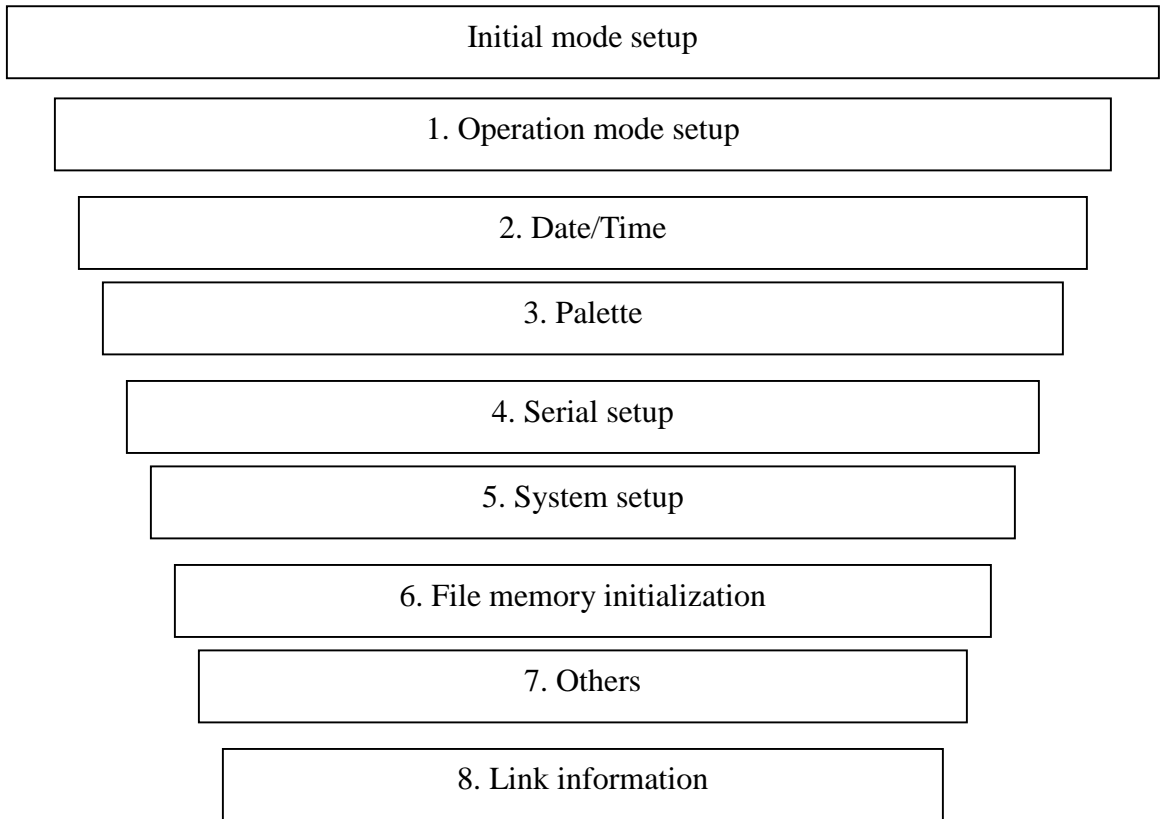

3-2-1. Operation mode setup

This mode set operation method, initial screen number, initial mode and used memory in operation.

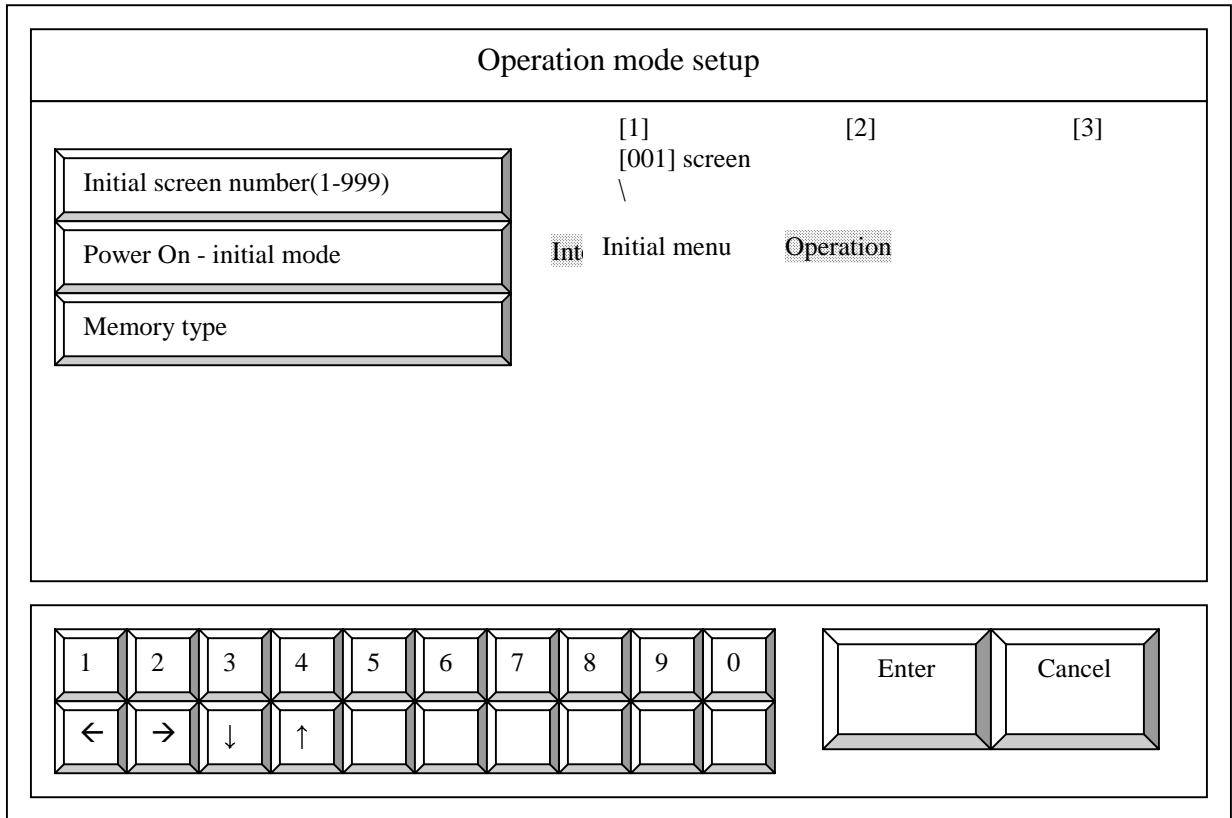

1:1 Communication mode : Serial, DLU, GLOFA Fnet

N:N Communication mode : Local-Master, Local

Operating method

1) Select Operation setup in the initial setup mode or press F1 function key.

2) To select the left menu

- Press “↑” key or press touch key to be edited

Press “↓” key or press touch key to be edited

3) Initial screen number (1-999) means the first screen to show up in the operation mode.

4) Power ON initial mode

5) When main unit power is on, a user can select direct operation(2) or main menu(1).

To select the menu, use → / ← key or 1(Initial menu(main menu)) /2(operation).

6) Memory select : Select memory type to communicate with PLC. (Internal memory or memory card)

To select the menu, use → / ← key or 1(Initial menu(main menu)) /2(operation).

7) communication type

Select communication method: 1:1 or N:N communication

8) 1:1 communication

Select one among Serial operation(1), DLU(Data Link Unit)(2) and GLOFA Fnet(3).

9) N:N communication

Select one between Local-Master and Local.

Local-Master: For a main unit to be connected to PLC directly.

Local : For communication among PMU main units.

Select one among Serial operation(1), DLU(Data Link Unit)(2) and GLOFA Fnet(3).

10) After select all menu, press Enter button or press Enter key of a keyboard.

To cancel the selected menu, press ESC button or press ESC key of a keyboard.

3-2-2. Date/Time

This mode sets date and time of a main unit.

Operating method

1) Select Date/Time setup in the initial setup mode or press F2 function key.

2) To select the left menu

- Press “↑” key or press touch key to be edited

Press “↓” key or press touch key to be edited

Or a user can select the menu directly by touching the menu bar.

3) Display method

Select ‘24hours display’ or ‘AM/FM display’

4) Date setup

Use a keyboard or ten-key below the main unit to setup current date.

5) Time setup

Use a keyboard or ten-key below the main unit to setup current date.

6) After enter all menus, press Enter button or press Enter key of a keyboard.

To cancel the selected menu, press ESC button or press ESC key of a keyboard.

Date/Time Setup	
Current Date :	December 1, 1997
Current Time :	15:03:18
Display Method	[24 hours AM/FM
Date Setup	[03] Minute
Time Setup	[12]hour [01]Minute [30]Second
Screen OFF time	

1	2	3	4	5	6	7	8	9	0	Enter	Cancel
←	→	↓	↑								

3-2-3. Palette











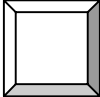

PMU main unit can display maximum 16colors(Mono: 16 Grays).



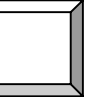
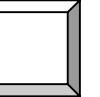
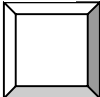





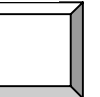
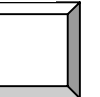







Operating method

- 1) Select Palette mode in the initial setup mode or press F3 function key.
- 2) After select color number to be changed, select new color to replace below the main screen.
New color can be selected by touching or cursor of a keyboard.
- 3) After setup palette, press Enter button or press Enter key of a keyboard.
To cancel the selected menu, press ESC button or press ESC key of a keyboard.

Palette

Palette Colors

0	1	2	3	4	5	6	7
							
8	9	A	B	C	D	E	F
							

																																																																																																																																																																																																																																																																																																																																																								
---	---	---	---	---	---	---	---	--	---	---	---	---	---	---	---	---	---	---	---	---	---	---	---	---	---	---	---	---	---	---	---	---	---	---	---	---	---	---	---	---	---	---	---	---	---	---	---	---	---	---	---	---	---	---	---	---	---	---	---	---	---	---	---	---	---	---	---	---	---	---	---	---	---	---	---	---	---	---	---	---	---	---	---	---	---	---	---	---	---	---	---	---	---	---	---	---	---	---	---	---	---	---	---	---	---	---	---	---	---	---	---	---	---	---	---	---	---	---	---	--	--	--	--	--	--	--	--	--	--	--	--	--	--	--	--	--	--	--	--	--	--	--	--	--	--	--	--	--	--	--	--	--	--	--	--	--	--	--	--	--	--	--	--	--	--	--	--	--	--	--	--	--	--	--	--	--	--	--	--	--	--	--	--	--	--	--	--	--	--	--	--	--	--	--	--	--	--	--	--	--	--	--	--	--	--	--	--	--	--	--	--	--	--	--	--	--	--	--	--	--	--	--	--	--	--	--	--	--	--	--	--	--	--	--	--	--	--	--	--	--	--	--	--	--	--	--	--	--	--	--	--	--	--	--	--	--	--	--	--	--	--	--	--	--	--	--	--	--	--	--	--	--	--	--	--	--	--	--	--	--	--	--	--	--	--	--	--	--	--	--	--	--	--	--	--	--	--	--	--	--	--	--	--	--	--	--	--	--	--	--	--	--	--	--	--	--	--	--	--	--	--	--	--	--	--	--	--	--	--	--	--	--	--	--	--	--	--	--	--	--	--	--	--	--

3-2-4. Serial Setup

This mode sets Baud rate, Parity bit, Data bit, Stop bit, RS232C/422 and Station number.

Serial Setup

	[1]	[2]	[3]
Baud rate (300-19200)	[19200] Baud rate		
Data bit	1 b 7 bits	8 bits	
Stop bit	RS232C	RS422	
Parity bit	[0] None	Even	Odd
Interface			
Station number(0-31)			

<table style="border-collapse: collapse;"> <tr> <td style="border: 1px solid black; padding: 2px 5px;">1</td> <td style="border: 1px solid black; padding: 2px 5px;">2</td> <td style="border: 1px solid black; padding: 2px 5px;">3</td> <td style="border: 1px solid black; padding: 2px 5px;">4</td> <td style="border: 1px solid black; padding: 2px 5px;">5</td> <td style="border: 1px solid black; padding: 2px 5px;">6</td> <td style="border: 1px solid black; padding: 2px 5px;">7</td> <td style="border: 1px solid black; padding: 2px 5px;">8</td> <td style="border: 1px solid black; padding: 2px 5px;">9</td> <td style="border: 1px solid black; padding: 2px 5px;">0</td> </tr> <tr> <td style="border: 1px solid black; padding: 2px 5px;"></td> <td style="border: 1px solid black; padding: 2px 5px;"></td> <td style="border: 1px solid black; padding: 2px 5px;"></td> <td style="border: 1px solid black; padding: 2px 5px;"></td> <td style="border: 1px solid black; padding: 2px 5px;"></td> <td style="border: 1px solid black; padding: 2px 5px;"></td> <td style="border: 1px solid black; padding: 2px 5px;"></td> <td style="border: 1px solid black; padding: 2px 5px;"></td> <td style="border: 1px solid black; padding: 2px 5px;"></td> <td style="border: 1px solid black; padding: 2px 5px;"></td> </tr> </table>	1	2	3	4	5	6	7	8	9	0											<table style="border-collapse: collapse;"> <tr> <td style="border: 1px solid black; padding: 5px; width: 50px;">Enter</td> <td style="border: 1px solid black; padding: 5px; width: 50px;">Cancel</td> </tr> </table>	Enter	Cancel
1	2	3	4	5	6	7	8	9	0														
Enter	Cancel																						

Operating method

- 1) Select Serial setup mode in the initial setup mode or press F4 function key.
- 2) To select the left menu
 - Press “↑” key or press touch key to be edited
 - Press “↓” key or press touch key to be edited
 Or a user can select the menu directly by touching the menu bar.
- 3) Setup baud rate of serial communication (300, 600, 1200, 2400, 4800, 9600, 19200).
To select the baud rate, use →(Increment) / ←(Decrement) key or →/← of a keyboard.
- 4) Data bit (7, 8 bits)
To select the Data bits, use →/← of a touch key or 1(7bits) / 2(8bits) of a keyboard.
- 5) Stop bit(1, 2bits)
To select the Stop bits, use →/← of a touch key or 1(1bit) / 2(2bits) of a keyboard.

6) Parity bits(None, Even, Odd)

To select the Parity bits, use →/← of a touch key or 1(None) / 2(Even) /3(Odd) of a keyboard.

7) Interface (RS232C/RS422)

To select the Stop bits, use →/← of a touch key or 1(RS232C) / 2(RS422) of a keyboard.

8) Self-station number (0-31)

Enter the number of the self-station using touch keys below the main unit or keyboard.

9) After enter all data, press Enter button or press Enter key of a keyboard.

To cancel the selected menu, press ESC button or press ESC key of a keyboard.

3-2-5. System setup

In this mode, User can set Buzzer beep, Screen blink interval, Password and Fonts.

Operating method

1) Select System setup mode in the initial setup mode or press F5 function key.

2) To select the left menu

- Press “↑” key or press touch key to be edited

Press “↓” key or press touch key to be edited

Or a user can select the menu directly by touching the menu bar.

3) Buzzer beep for touch key

To select the type, use →/← of a touch key or 1(Yes) / 2(No) of a keyboard.

4) Tone of buzzer beep (1-31)

It can be selectable up to 31 step. Lower number makes beep larger.

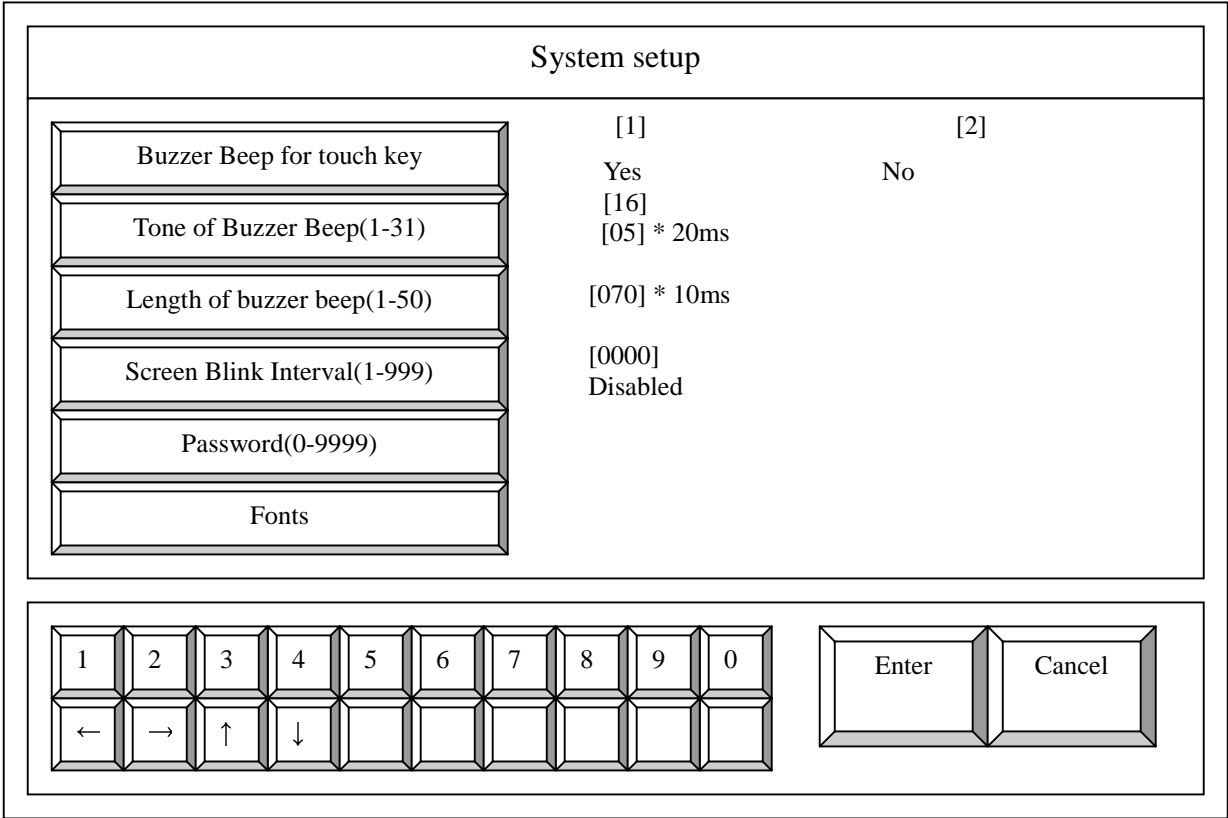

- 5) Length of buzzer beep (1-50). Selected length unit is 20ms.
Use ten-key or keyboard to enter the number.
- 6) Screen blink interval (1-999)
This menu can adjust the conversion speed of a symbol or message tag in the main unit
Unit of the speed is 10ms. Use ten-key or keyboard to enter the number.
- 7) Password (4-digit)
This password is necessary to confirm the initialization of internal memory or memory card.
- 8) After select all data, press Enter button or press Enter key of a keyboard.
To cancel the selected menu, press ESC button or press ESC key of a keyboard.

3-2-6. File memory initialization

This menu is used for initialization of internal memory, memory card and the data of initial screen.

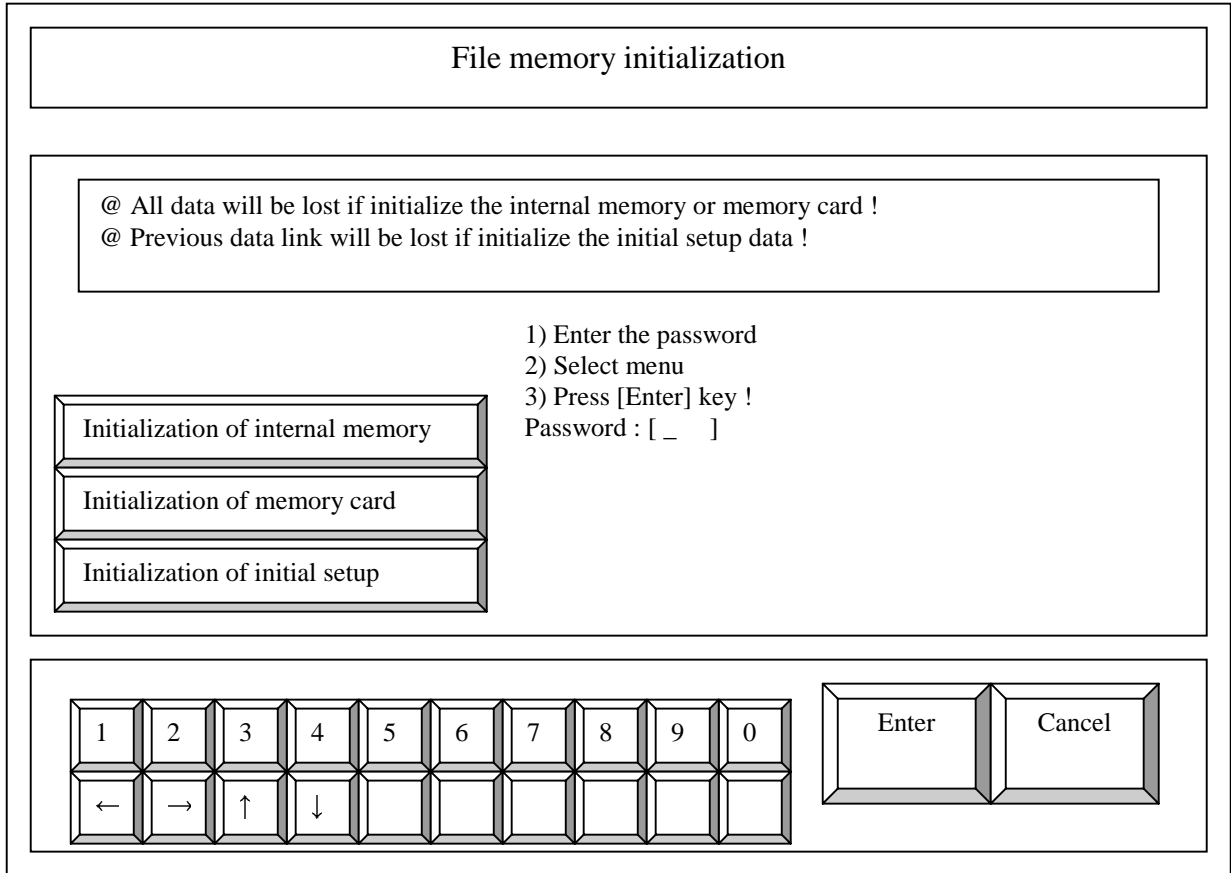

Operating method

- 1) Select File memory mode in the initial setup mode or press F6 function key.
- 2) Initialization of internal memory
To initialize the memory, select the button and enter the password and press Enter key.
- 3) Initialization of memory card
Same as the above.
- 4) Initialization of initial setup
This menu is to clear the initial setup data including link edit.

3-2-7. Others

In this mode, a user can set the size of alarm messages and the position to be displayed.

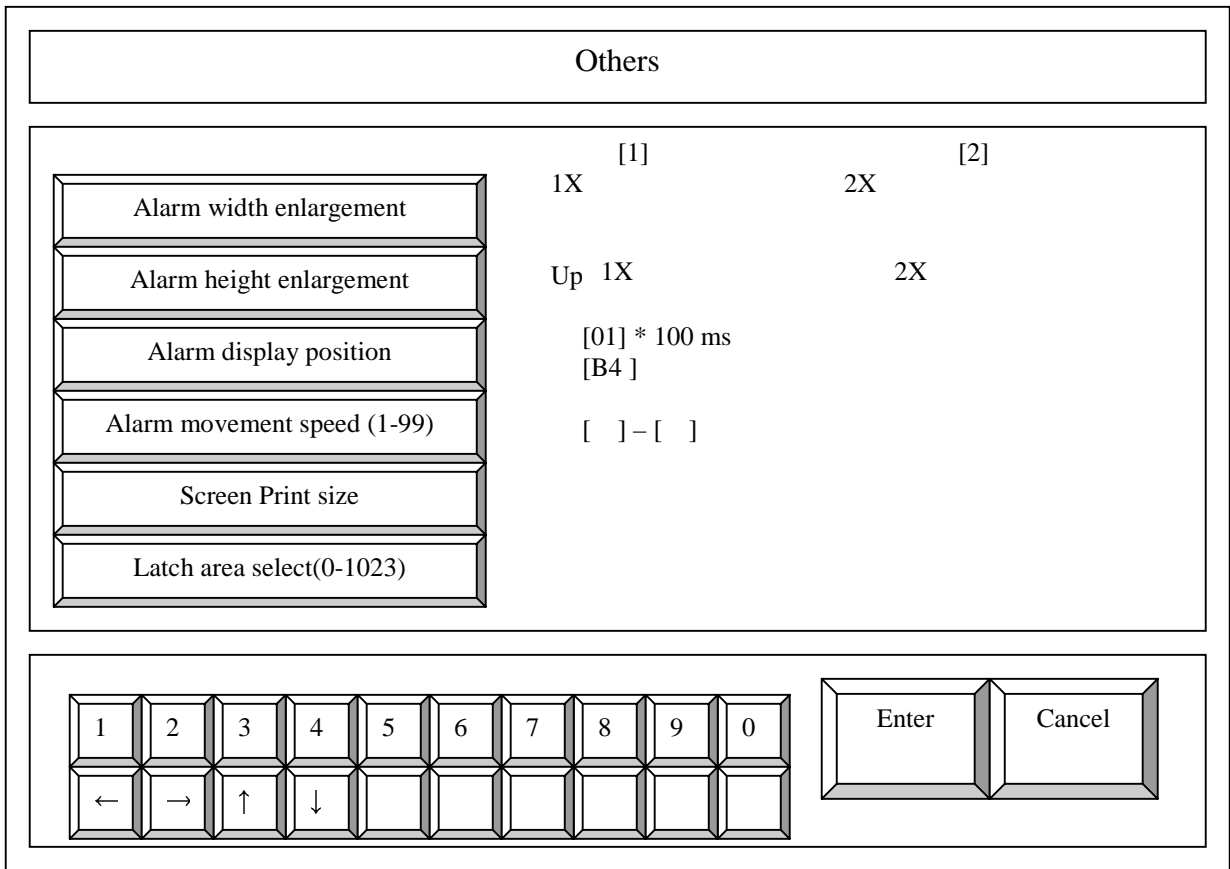

Operating method

- 1) Select others in the initial setup mode or press F7 function key.
- 2) Alarm width and height enlargements are to setup the size of alarm message.
To setup size, use →/← of a touch key or 1 / 2 of a keyboard.
- 3) Alarm display position
1:Upper of the screen, 2: Below of the screen
- 4) Alarm movement speed
Maximum 9.9seconds /10ms
- 5) Screen print size
A4(136X101mm), B4(271X205mm), A4 Dither, B4 Dither etc.
- 6) Latch area select(0-1023)

This area can save all data even if power is off.

Note) Please remember Super capacitor of SRAM can save the data only 7 Dates.

7) After setup all data, press Enter button or press Enter key of a keyboard.

To cancel the selected menu, press ESC button or press ESC key of a keyboard.

3-2-8. Link setup

1. Communication Method

1:1, N:N, User defined protocol

2. Communication mode

1) 1:1 communication

- Serial interface(RS232C/RS422)

- GLOFA GM series
- GLOFA K series
- Master K series : Master-K10S, 30S, 60S, 100S, 500H and 1000H
- Micrex PLC(Fuji Electric)
- Mitsubishi PLCs : AnN, AnA AnU series
- OMRON PLCs
- Samsung Electronics(FARA PLCs)
- LG Inverter

- High speed communications

Data Link: Master-K series, Mitsubishi AnN, AnA series, FAM(Factory Automation Manager)

2) N:N communication

Local-Master: For a main unit to be connected to PLC directly.

Local : For communication among PMU main units.

3) User defined Protocol communication

3. PLC Type

1:1 -> Selected PLC

N:N -> Local-Master : Selected PLC

Local : Not shown(GLOFA GM PLC)

User defined protocol -> Not shown

3-3. Transfer

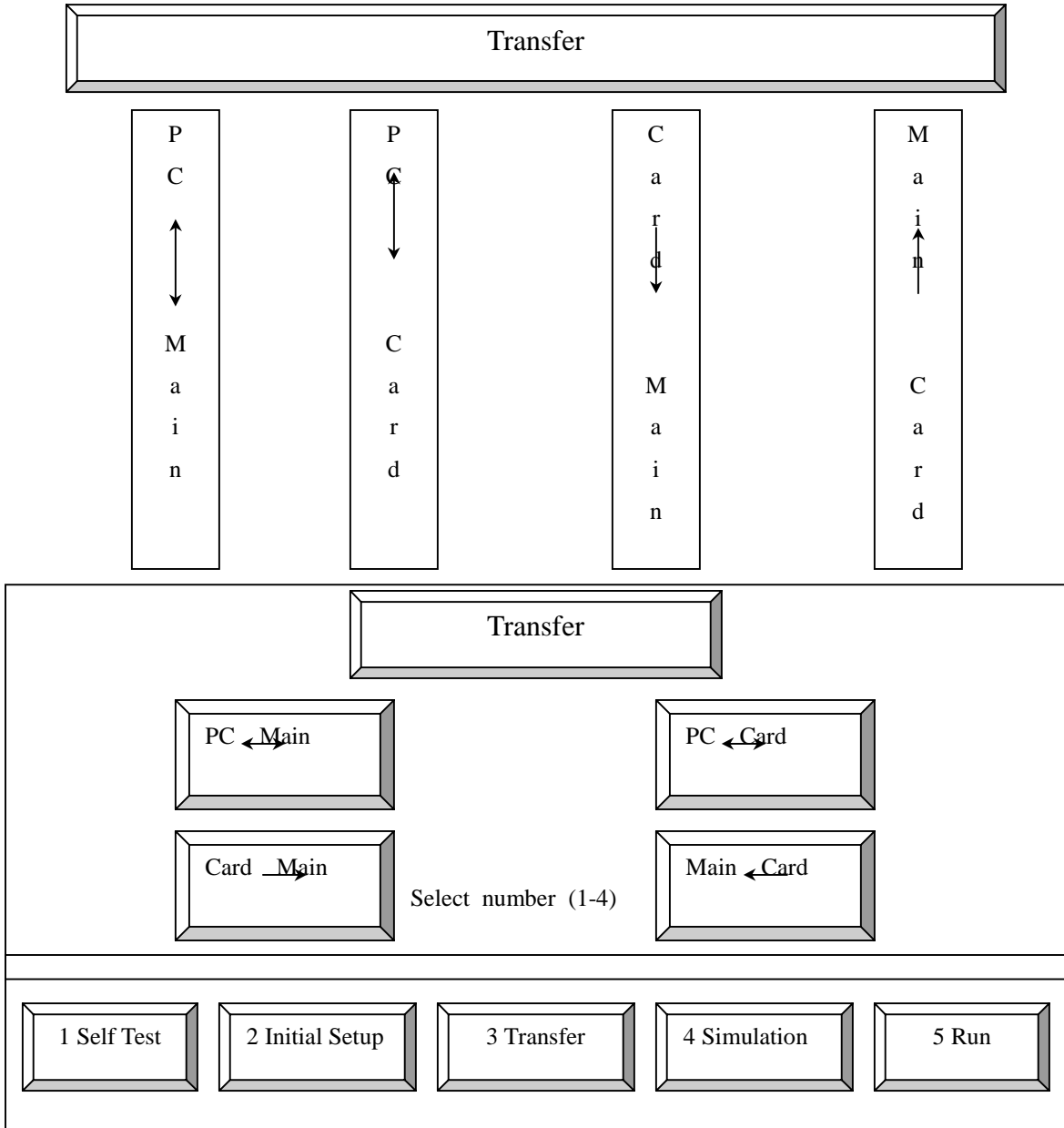

3-3-1. PC ↔ Main unit

Transfer screen files created in PMU Master S/W to the Main unit.

A user can not only download files from PMU Master S/W to the main unit but also upload to the PC.

This files for transfer should be *. prj files(project files).

Operating method

- 1) Press F1 function key or PC \leftrightarrow Main unit touch key in the transfer mode.
- 2) Enter a password
- 3) Press Enter key to be ready
- 4) Transfer the files to the main unit using the project manager of the PMU Master S/W.
(Please refer to the Software manual for PC Operation)
You can see the message "Executing transfer...".
- 5) After completion, The data is saved to the internal memory with the message 'memory write'.
- 6) Completed! <KEY> message is shown to the main unit after execution.
- 7) To interrupt transfer, press ESC key.

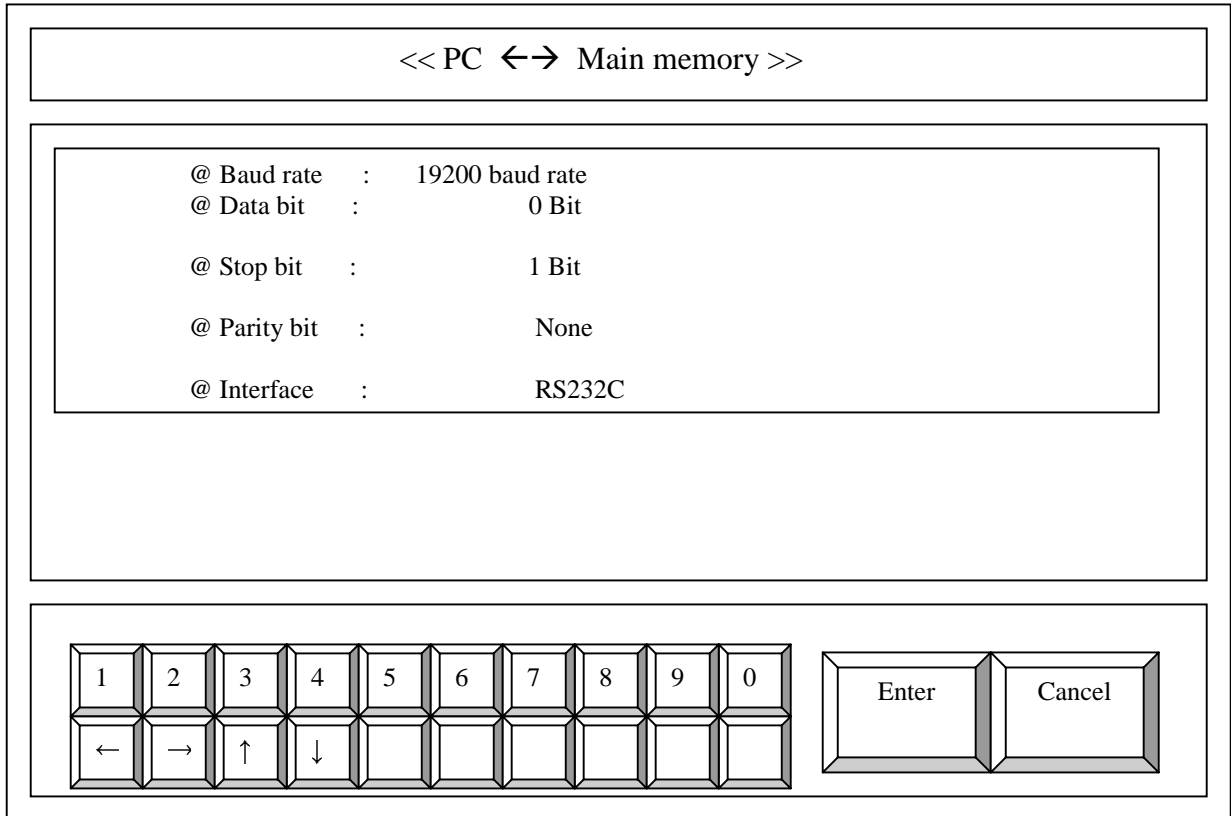

3-3-2. PC \leftrightarrow CARD

In this mode, a user can transfer files from PC to memory card.

- 1) Press F2 function key or PC← → Card touch key in the transfer mode.
- 2) Enter a password
- 3) Press Enter key to be ready
- 4) You can see the message “ Executing transfer...”
- 5) Completed! <KEY> message is shown to the main unit after execution.
- 6) To interrupt transfer, press ESC key.

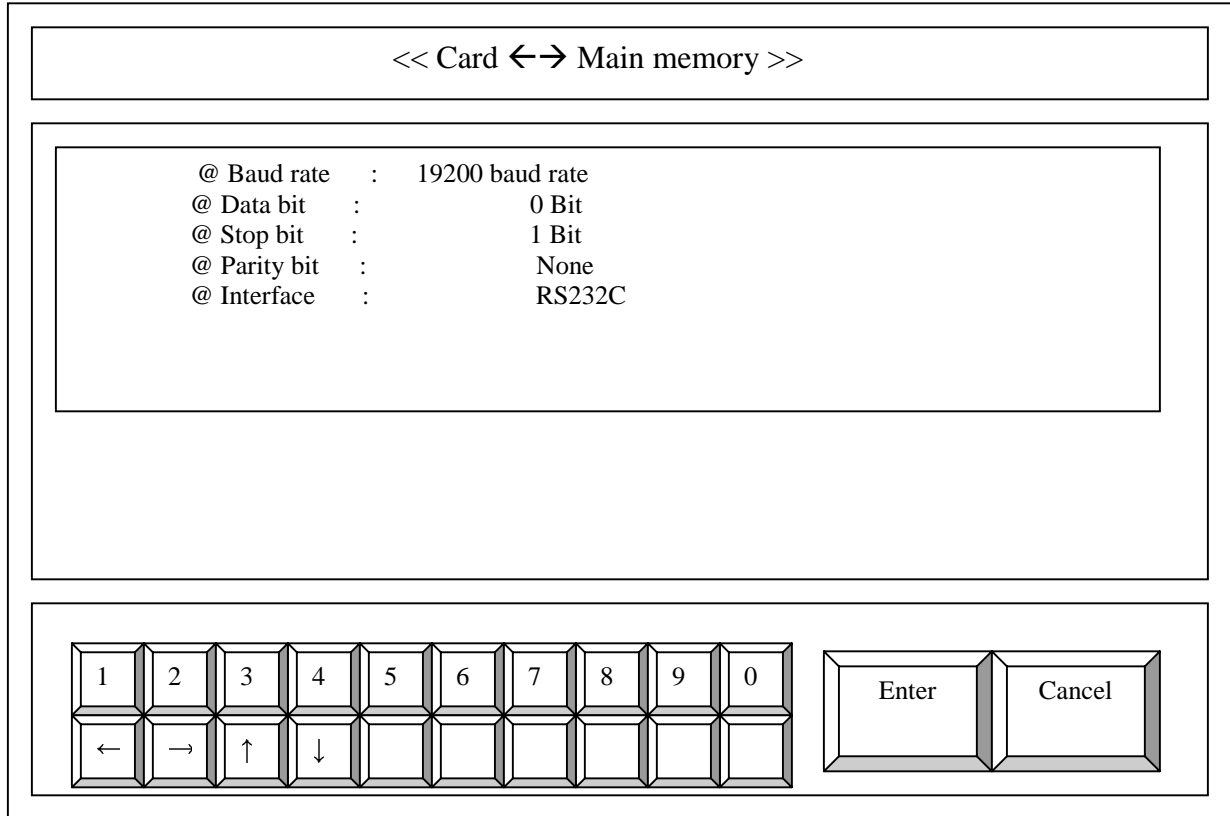

3-3-3. Card → Mian unit

In this mode, a user can transfer files from memory card to the Main unit.

- 1) Press F3 function key or PC → Card touch key in the transfer mode.
- 2) Enter a password
- 3) Press Enter key to be ready
- 4) You can see the message “ Being copied to main memory....”
- 5) Completed! <KEY> message is shown to the main unit after execution.
- 6) To interrupt transfer, press ESC key.

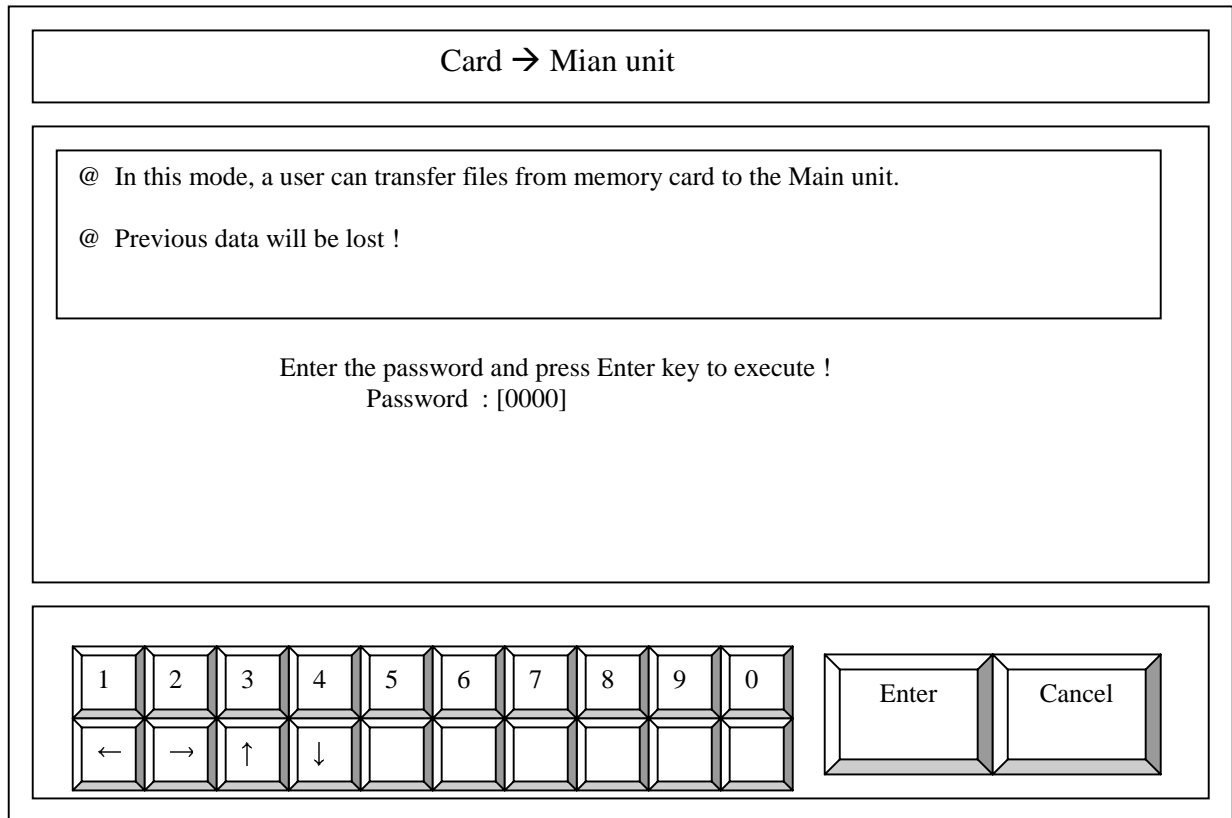

3-3-4. Main unit → Memory Card

In this mode, a user can transfer data from internal memory of main unit to Memory card.

- 1) Press F4 function key or Main unit → Memory Card touch key in the transfer mode.
- 2) Enter a password
- 3) Press Enter key to be ready
- 4) You can see the message “ Being copied to memory card....”
- 5) Completed! <KEY> message is shown to the main unit after execution.
- 6) To interrupt transfer, press ESC key.

Mian unit → Card																								
<p>@ In this mode, a user can transfer files from the Main unit to memory card.</p> <p>@ Previous data will be lost !</p> <p style="text-align: center;">Enter the password and press Enter key to execute ! Password : [0000]</p>																								
<table border="1" style="margin: auto; border-collapse: collapse;"> <tr> <td style="padding: 2px 5px;">1</td><td style="padding: 2px 5px;">2</td><td style="padding: 2px 5px;">3</td><td style="padding: 2px 5px;">4</td><td style="padding: 2px 5px;">5</td><td style="padding: 2px 5px;">6</td><td style="padding: 2px 5px;">7</td><td style="padding: 2px 5px;">8</td><td style="padding: 2px 5px;">9</td><td style="padding: 2px 5px;">0</td> <td style="padding: 5px 10px; text-align: center;">Enter</td> <td style="padding: 5px 10px; text-align: center;">Cancel</td> </tr> <tr> <td style="padding: 2px 5px;">←</td><td style="padding: 2px 5px;">→</td><td style="padding: 2px 5px;">↑</td><td style="padding: 2px 5px;">↓</td><td></td><td></td><td></td><td></td><td></td><td></td> <td></td><td></td> </tr> </table>	1	2	3	4	5	6	7	8	9	0	Enter	Cancel	←	→	↑	↓								
1	2	3	4	5	6	7	8	9	0	Enter	Cancel													
←	→	↑	↓																					

3-4. Simulation

3-4-1. Simulation

This function is used when a user wants to confirm how the created screen will actually operate in PC or PMU main unit.

The simulation mode has a dialog box writing buffer value, which will get from PLC in operation mode, using keyboard.

This function is so useful to check the registered tag before installing the main unit to a plant line or panel.

The initial screen registered in the main unit displays in simulation mode.

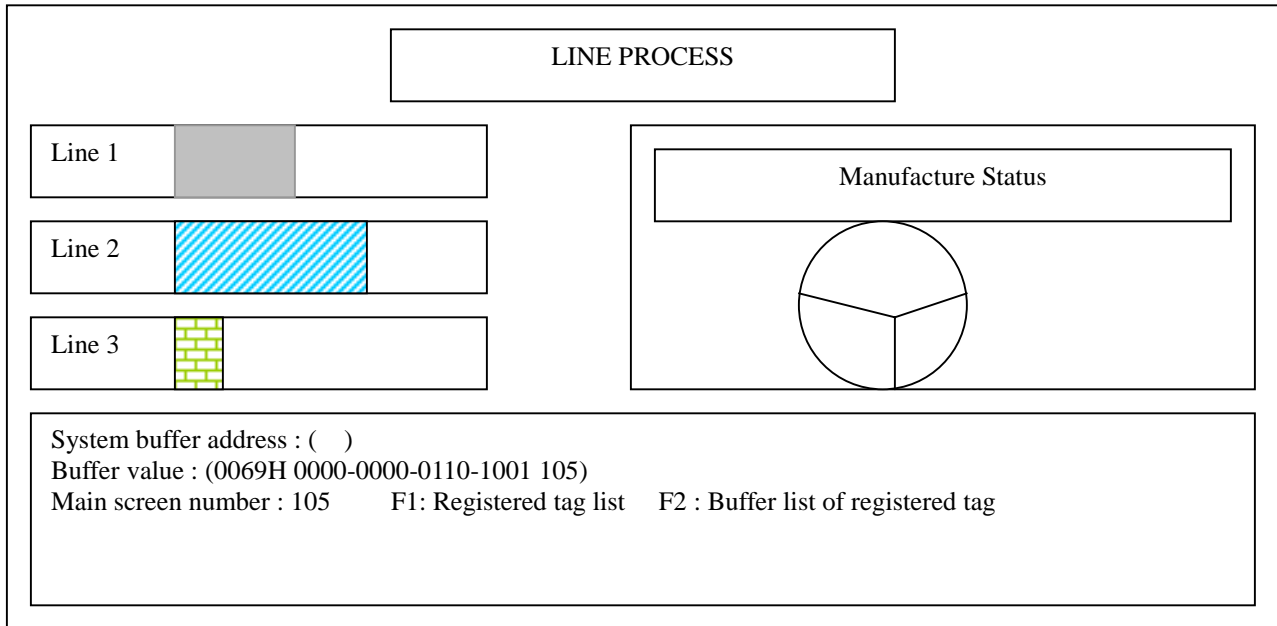

Operating Method

- 1) Select Simulation mode in the main menu. Then you will find main screen(initial screen) registered in operation setup mode and dialog box to enter data for simulation.
- 2) To enter data to a system buffer,
 - After enter the system buffer address press Enter key. Then the data will be shown to a user with hex, binary or decimal value.
 - When a user enter data to a system buffer, just enter the data if the data is decimal value. But it's hex value a user should add H in front of the value.
- 3) To change the position of dialog box, press Home key. Then the position will be changed into UP, Down position or Not shown .
- 4) To escape from the simulation mode, press ESC key. Then the message “ Exit (Y/N) ? ” displays.

3-4-2. View Tag list

A user can view the list of tags displayed in simulation mode.

View Tag list	
Tag Name	System buffer address
G10	40
G11	41
G100	42

To continue[Enter], To cancel [ESC]

Operating method

1) Press F1 key in the simulation mode. Then the tags registered in the main screen will be shown.
Each Tag lists will be shown to the list by Enter key.

(Tag list order)

1. Numeric Tag 2. Auxiliary Tag 3. Symbol tag 4. Touch tag 5. Key tag 6. Key display tag 7. Level graph tag
8. Statistic tag 9. Area move tag 10. Precision adjust tag 11. Buffer write tag 12. Move tag 13. Message tag
14. Trend tag 15. Lamp tag 16. Delay tag 17. Computation tag 18. Block tag 19. Function key tag
20. Pie graph tag

3-4-3. View Buffer list of registered tags

This function is to view buffer list of registered tags in the main screen.

View Buffer list							
0	K0	K1	K2	K3	K4	K5	Km
20	Ttt						
21							
40	P1	G10					
41	P2	G11					
200	N5	Ke					
Start address : <input style="width: 50px;" type="text"/> After enter a start address, press [Enter] key.							

Operating method

- 1) Press F2 in simulation mode.
- 2) After enter a start address of system buffer, press [Enter] key. Then the specified system buffer displays the
List of tags registered in each system buffers.
- 3) To continue press [Enter] key.
- 4) To escape from this mode, press ESC key.

3-5. Operation

Sending and receiving between main unit and PLC use system buffer address of PMU.

Data of system buffer indicate graphics or texts displayed in the main screen.

PLC can only write data to system buffer area or read data from system buffer area.

Confirm the following items before operation.

- 1) Designate initial setup and communication setup correctly in the main unit.
- 2) Confirm the connection between PLC and main unit.
- 3) Confirm the screen data , which created in PMU Master s/w, in simulation mode before transfer the data to main unit.

[Appendix]

A. SYSTEM BUFFER

A-1. Definition

System buffer is memory area saving screen control data or error information necessary to operation mode. It consists of 1024 system buffer memories. All data for communication will be saved into system buffer area.

A-2. System buffer Map

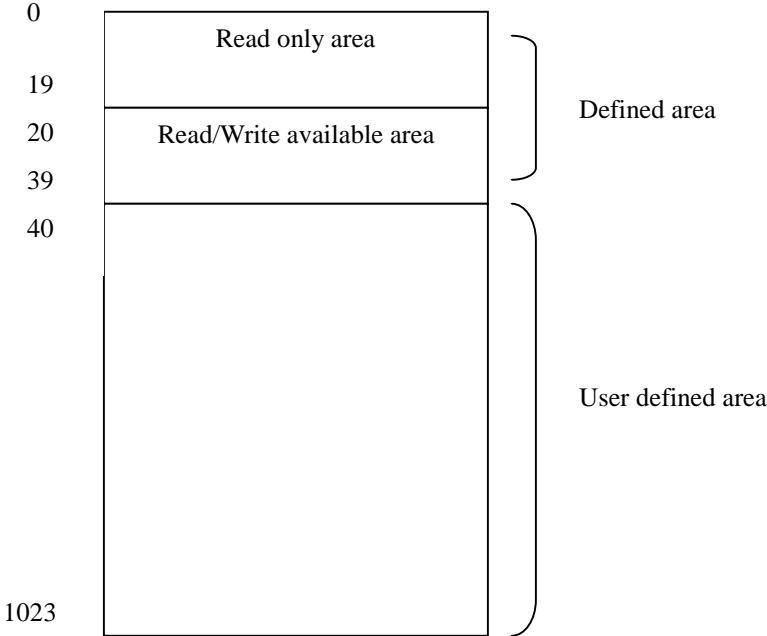

A-3. Description of System buffer

- Read-only System defined buffer

Buffer address		Bit	Contents	
0	System error	0	System ROM error	
		1	System RAM error	
1	Serial comm. error	0	Frame error	
		1	Parity error	
		2	Overrun error	
		3	Time out error	
		4	Protocol error	
		5	Check sum error	
2-6	Fnet error	0-15	GLOFA Fnet information	
7	Not used			
8				
9	Year	0-15	Clock	Year (BCD 16bits : 2 digits)
10	Month	0-15		Month (BCD 16bits : 2 digits)
11	Date	0-15		Date (BCD 16bits : 2 digits)
12	Hour	0-15		Hour (BCD 16bits : 2 digits)
13	Minute	0-15		Minute (BCD 16bits : 2 digits)
14	Second	0-15		Second (BCD 16bits : 2 digits)
15	Fixed value	0-15	When power is on, it always keeps 0 value.	
16	Fixed value	0	When power is on or changes screen, 0 → 1 No.0 bit will be on.	
17		0-15	Reserved area	
18	System clock	0-15	1 second clock	
19	Aux. Input buffer	0-2	Data from auxiliary port (8bits)	

- Read/Write System defined buffer

20	Main screen number	0-15	This buffer can save main screen number to be displayed. If a user wants to change screen into another, enter the screen number to be changed to this buffer.
21	Key display	0-15	Data for Key display tag (lower word)
22	Key display	0-15	Data for Key display tag (upper word)
23	TenKey Enter information	0	When press [enter] key of tenkey, 0 bit will be 1.
24-25		0-15	Reserved area
26	Call previous screen	0-15	If data of this buffer is not '0', it calls previous screen.
27	Exit	0-15	If data of this buffer is not '0', Operation will be end.
30	Buzzer output time	0-15	Buzzer output time of auxiliary port
31	Aux. Output information	0-7	Output data (8 bit)of auxiliary port
32-39	Screen Off setup	0-15	If data of this buffer is not '0', Back light will be Off.

- User defined buffer

Read/Write available in this buffer area : 40 ~ 1023 buffers

B. Application examples

B-1. PLC Communication specification

B-1-1. PLC Types and communication method

1:1 communication

Serial interface(RS232C, RS44)

Datalink

GLOFA Fnet

T-link

User defined protocol

N:N communication

RS422 for MASTER link

Fnet for LOCAL link

Method	Comm. mode	PLC Type	PLC CPU type	Comm. Interface module
1:1	Serial I/F	Master-K Series	Master K500/1000 CPU	
		GLOFA-GM	GOL-CPU	
		GLOFA-K		
		Mitsubishi(A2N, A3N)		AJ71UC24
		Mitsubishi(A1S)		
		OMRON	C200H	
		Samsung FARA		
		Fuji PLCs		FFU120B, FFK120A
		LG Inverter		
	Data Link	Master-K200/500/1000h		DLU module
		FAM 3.1, 4.0		
	GLOFA Fnet	GM1/2/3/4/5		GLOFA Fnet module
		FAM 4.0		
PMU-500				
T-link	Micrex (Fuji PLCs)			
User defined	-			
N:N	Master	Master K series	MK 500/1000	
		Mitsubishi AnN		MJ71UC24
		Mitsubishi AnA		
		Micrex (Fuji)	80/120H, 120S/140S/150S	FFU120B, FFK120A
		Samsung FARA		
	Local	GM1/2/3/4/5		GLOFA Fnet module
		FAM		
		PMU-500		

B-1-2. Setup items

B-1-2-1. Serial setup items (1:1 Comm.)

Baud rate	300, 600, 1200, 2400, 4800, 9600, 19200
Data Bit	7 bit, 8 bit [Note] Master-K : 8 bit
Stop Bit	1 bit, 2 bit [Note] Master-K : 1 bit
Parity Bit	No parity, Odd parity, Even parity [Note] Master-K : No parity
Interface	RS232C, RS422
Station no.	Master-K1000 : Up to 0-15 Stations Others : 0-31 Stations
Check sum	Always Yes (Except for Micrex)

B-2. PLC Communication flow chart.

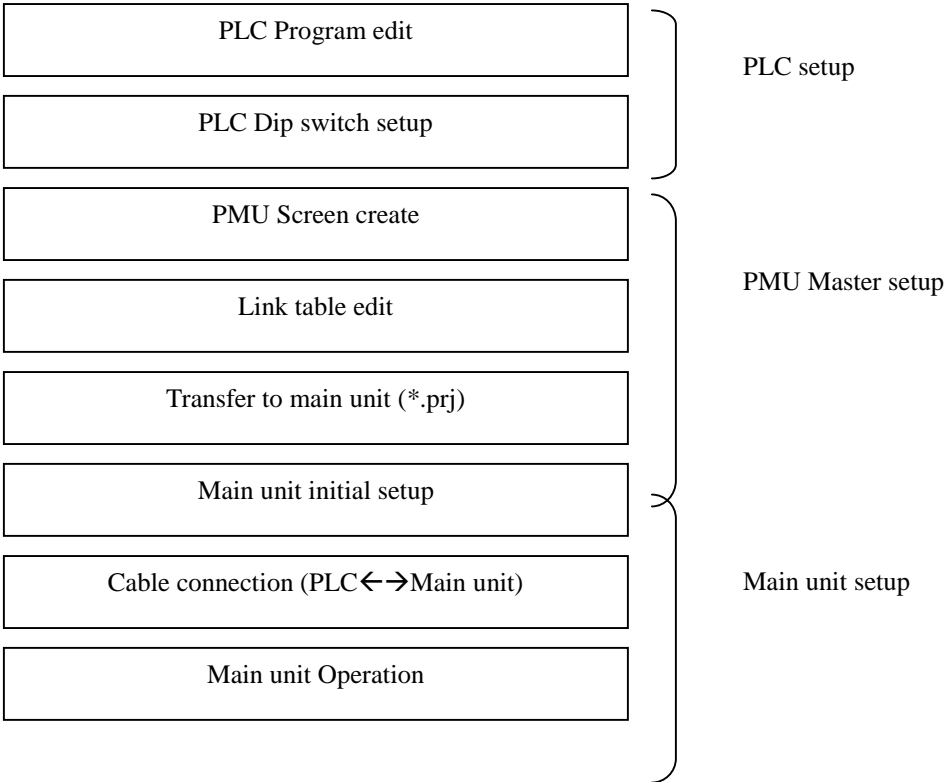

B-3-1-2. Master-K 30S, 60S K101S

B-3-1-2-1. PMU main unit Setup

Operation mode setup**Operation mode setup**

- Select [Initial Menu] → [Operation Setup]
 [Initial screen number]: 0-999 select
 [Power On initial mode]: Initial menu or Operation
 [Memory type]: Internal memory or Memory card

Serial mode setup

Baud rate	300 bps, 600 bps, 1200 bps, 2400bps, 4800bps, 9600bps, 19200bps
Data bit	8 Bits
Stop bit	1 Bit
Parity bit	None
Serial Interface	RS232C (Loader port)
Station Number	None

Link Editor (PC→ PMU Main unit)

- Select Master-K S/H series
- In link table, setup PLC Device, Buffer, Word and Station number
- Please refer to Master-K S/H type address allocation table
- Please refer to Link editor for the detail information.

B-3-1-2-2. PLC Setup

Hardware Dip switch select (Master-K S/H Series)

Master-K S Series can do communicate with PMU main unit through RS232C interface using loader port.
 Baud rate will be fixed with 9600 bps

B-3-1-2-3. PLC Address allocation table(Master-KS/H Series)

Memory area	Address		
	K10S,K30S,K60S,K100S	K10S1	K60H, K200H
AuxiliaryRelay (M)	M0000-M0031	M0000-M0015	M0000-M0063
I/O Relay (P)	P0000-P0005	P0000-P0001	P0000-P0255
Keep Relay (K)	K0000-K0015	K0000-K0007	K0000-K0511
Link Relay (L)	L0000-L0015	L0000-L0007	L0000-L0255
Special Relay (F)	F0000-F0015	F0000-F0015	F0000-F0255
Timer- current value (T)	T0000-T0127	T0000-T0047	T0000-T0255
Counter-current value (C)	C0000-C0127	C0000-C0015	C0000-C0255
Data Register (D)	D0000-D0255	D0000-D0063	D0000-D1023

B-3-1-2-4. Cable connection (PMU↔ PLC)

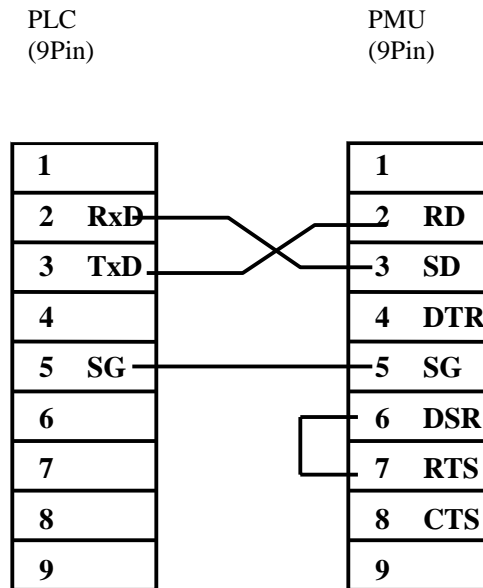

B-3-1-3. GLOFA-GM Cnet Setup

B-3-1-3-1. PMU main unit setup

Operation mode setup

- Select [Initial Menu] → [Operation Setup]
 [Initial screen number]: 0-999 select
 [Power On initial mode]: Initial menu or Operation
 [Memory type]: Internal memory or Memory card

Serial mode setup

Baud rate	300 bps, 600 bps, 1200 bps, 2400bps, 4800bps, 9600bps, 19200bps
Data bit	8 Bits
Stop bit	1 Bit
Parity bit	None
Serial Interface	RS232C (Cnet module)
Station Number	None

Link Editor (PC → PMU Main unit)

- Select GLOFA-GM (Cnet) series
- In link table, setup PLC Device, Buffer
- Please refer to GLOFA-GM(Cnet) address allocation table.
- Please refer to Link editor for the detail information

B-3-1-3-2. PLC Setup

Hardware Rotary switch select (GLOFA-GM Cnet)

Mode	Description
1	RS232C Mode
3	RS232C / RS422 Mode
4	RS422 Mode
5	RS232C Mode
7	RS422 Mode

* Station number setup : Use Frame editor software*

* PMU Communication : Select 3 mode(RS232C/RS422 mode)

B-3-1-3-3. PLC Address allocation table(GLOFA-GM)

Type	Word	Address Map
GM1	%IX	%IW0.0.0 ~ %IW63.7.3
	%QX	%QW0.0.0 ~ %QW63.7.3
	%M	%MB0 ~ %MB65535
GM2	%IX	%IW0.0.0 ~ %IW31.7.3
	%QX	%QW0.0.0 ~ %QW31.7.3
	%M	%MB0 ~ %MB65535
GM3	%IX	%IW0.0.0 ~ %IW7.7.3
	%QX	%QW0.0.0 ~ %QW7.7.3
	%M	%MB0 ~ %MB32767
GM4	%IX	%IW0.0.0 ~ %IW7.7.3
	%QX	%QW0.0.0 ~ %QW7.7.3
	%M	%MB0 ~ %MB16383
GM5	%IX	%IW0.0.0 ~ %IW1.9.3
	%QX	%QW0.0.0 ~ %QW1.9.3
	%M	%MB0 ~ %MB8191

Example : %MW0000
 %Q(I)W0.0.0



Base, Slot, Card [Please refer to GLOFA-GM Manual]

B-3-1-3-4. Cable connection (PMU↔PLC)

RS-232C connection (9 Pin port)

Pin No.	Description	Signal	Direction
1	Carrier Detect	CD	
2	Sending Data	SD(TXD)	—————>
3	Receiving Data	RD(RXD)	<—————
4	Data Terminal Ready	DTR	—————>
5	Signal Ground	SG	
6	Data Set Ready	DSR	<—————
7	Request Sending	RS(RTS)	—————>
8	Confirm Sending	CS(CTS)	<—————
9		RI	

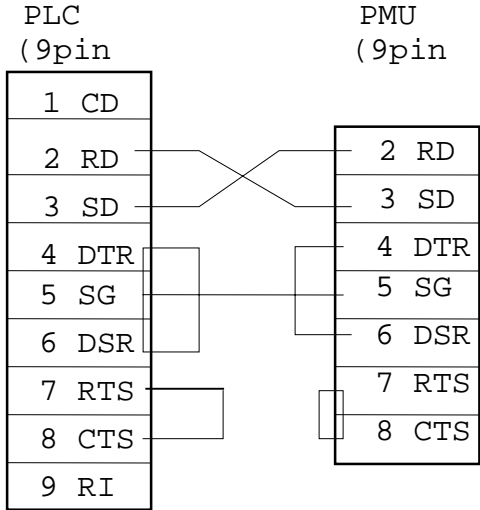

RS-422 connection (6 Pin Port)

Pin No	Description	Signal	Direction
1	Receiving Data A	RDA	←
2	Receiving Data B	RDB	←
3	Sending Data A	SDA	→
4	Sending Data B	SDB	→
5	Signal Ground	SG	
6	Frame Ground	FG	

